

HIDALGO COUNTY REGIONAL MOBILITY AUTHORITY

NOTICE OF AND AGENDA FOR A WORKSHOP AND REGULAR MEETING TO BE HELD BY THE BOARD OF DIRECTORS

DATE: TUESDAY, APRIL 28, 2026
TIME: 4:30 PM
PLACE: PHARR CITY HALL
2nd FLOOR CITY COMMISSION CHAMBERS
118 SOUTH CAGE BLVD.
PHARR, TEXAS 78577

PRESIDING: ROBERT L. LOZANO, CHAIRMAN

An electronic copy of the agenda packet can be obtained at www.hcrma.net

PLEDGE OF ALLEGIANCE

INVOCATION

CALL TO ORDER OF A WORKSHOP

1. Review of Fiscal Year 2025 Financial Statement and Independent Auditors Report for the Hidalgo County Regional Mobility Authority.
2. Review of Fiscal Year 2025 Annual Compliance Report for the Hidalgo County Regional Mobility Authority.
3. Review of Quarterly Investment Report for the period ending March 31, 2026.
4. Rio Grande Valley Metropolitan Planning Organization presentation.

ADJOURNMENT OF WORKSHOP

CALL TO ORDER AND ESTABLISHMENT OF A QUORUM FOR A REGULAR MEETING

PROCLAMATION

Pilar Rodriguez, PE (April 2012 to April 2026)

PUBLIC COMMENT

1. CHAIRMAN'S REPORT

- A. Western Hidalgo County Loop System Development.
- B. Status Reports from Administration, Project, and Revenue Committees.

2. STAFF REPORTS

- A. Report on Program Management Activity for the 365 Tollway Project – Ruben Alfaro, HCRMA
- B. Report on Construction Activity for the 365 Tollway Project – Ramon Navarro IV, HCRMA

3. CONSENT AGENDA *(All matters listed under Consent Agenda are considered to be routine by the Governing Body and will be enacted by one motion. There will be no separate discussion of these items; however, if discussion is desired, that item(s) will be removed from the Consent Agenda and will be considered separately. The Governing Body may also elect to go into Executive Session on any item on this agenda, whether or not such item(s) are posted as an Executive Session Item, at any time during the meeting when authorized by provisions of the Open Public Meeting Act.)*

- A. Approval of Minutes for the Regular Board Meeting held March 24, 2026.
- B. Approval of Project & General Expense Report for the period from March 7, 2026 to April 6, 2026.
- C. Approval of Financial Reports for February 2026.
- D. Approval of Quarterly Investment Report for the Period ending March 31, 2026.
- E. Resolution 2026- 45 - Approval of the Hidalgo County Regional Mobility Authority Designee, Alternate, and Proxy to the Rio Grande Valley Metropolitan Planning Organization.
- F. Resolution 2026-46 – Approval and Consideration to designate Jose Castillo and Daniel Garcia as investment officers for the Hidalgo County Regional Mobility Authority.
- G. Resolution 2026-47 – Authorization to remove Pilar Rodriguez as a signatory and the addition of Daniel Garcia, Executive Director, as an authorized signatory on the PlainsCapital, Wilmington Trust, and Logic accounts.

4. REGULAR AGENDA

- A. Resolution 2026-29 – Consideration and acceptance of Fiscal Year 2025 Financial Statement and Independent Auditors Report for the Hidalgo County Regional Mobility Authority.
- B. Resolution 2026-30 – Consideration and approval of Fiscal Year 2025 Annual Compliance Report for the Hidalgo County Regional Mobility Authority.
- C. Resolution 2026-32 – Consideration and authorization to reimburse the Texas Department of Transportation (TxDOT) for survey work for the SH 68/FM 3072/Spur 81 (IBTC) Project to allow for transfer of right of ways to TxDOT from the Hidalgo County Regional Mobility Authority.
- D. Resolution 2026-40 – Consideration and approval of change order number 2 to the contract with SICE, Inc. to provide toll collection system installation, integration and maintenance for the 365 tollway project.
- E. Resolution 2026-41– Consideration and approval of change order number 3 to the contract with SICE, Inc. to provide toll collection system installation, integration and maintenance for the 365 tollway project.
- F. Resolution 2026-42–Consideration and approval of agreement with AEP Texas, Inc. to Install Electric Distribution Facilities for New Electrical Services for the 365 Tollway Project.
- G. Resolution 2026-43–Consideration and approval of Supplemental number 2 to Work authorization Number 1 to the Professional services agreement with Alliance Geotechnical Group, Inc. to provide drill shaft testing as part of the 365 Tollway Project.
- H. Resolution 2026-44– Consideration and Approval of Contract Amendment Number 2 to the professional service agreement with Alliance Geotechnical Group, Inc. to increase maximum payable amount for Supplemental number 2 to Work authorization Number 1.
- I. Resolution 2026-48 – Consideration and approval of Change Order Number 22 to that certain contract with Pulice Construction, Inc. for the 365 Tollway construction project.

5. TABLED ITEMS

- A. None.

6. EXECUTIVE SESSION, CHAPTER 551, TEXAS GOVERNMENT CODE, SECTION 551.071 (CONSULTATION WITH ATTORNEY), SECTION 551.072 (DELIBERATION OF REAL PROPERTY), AND SECTION 551.074 (PERSONNEL MATTERS)

- A. Consultation with Attorney on legal issues pertaining to Red River Subdivision (551.071 T.G.C.).
- B. Consultation with Attorney on legal issues pertaining to the advance project development of the 365 Tollway Segment 4, Section "A" West and Section "C" of the Hidalgo County Loop System (Section 551.071 T.G.C.).
- C. Consultation with Attorney on legal issues pertaining to a Memorandum of Understanding between the Hidalgo County Regional Mobility Authority and Hidalgo County for Section "A" West (Section 551.071 T.G.C.).
- D. Consultation with Attorney on legal issues pertaining to the Joint Use Agreement between Hidalgo County Irrigation District Number 2 and the Hidalgo County Regional Mobility Authority for the 365 Tollway Project (Section 551.071 T.G.C.).
- E. Consultation with Attorney on legal issues pertaining to that certain contract with Pulice Construction Inc. for the 365 Tollway Project.
- F. Consultation with Attorney on legal issues pertaining to Change Order Number 1-16 to that certain contract with Pulice Construction Inc. for the 365 Tollway Project (Section 551.071 T.G.C.).
- G. Consultation with Attorney on legal issues pertaining to the Financial Assistance Agreement with the Texas Department of Transportation for the 365 Tollway Project (Section 551.071 T.G.C.).
- H. Consultation with Attorney on legal issues pertaining to Professional Service Agreements for Inspection, Engineering, Surveying and Environmental Services to include construction material testing (Section 551.071 T.G.C.).
- I. Consultation with Attorney on legal issues pertaining to the voluntary acquisition of real property for various parcels for the 365 Tollway Project and International Bridge Trade Corridor Project (Sections 551.071 and 551.072 T.G.C.).
- J. Consultation with Attorney on legal issues pertaining to the acquisition, including the use of Eminent Domain, for property required to complete the project alignments of the 365 Tollway Project (Sections 551.071 and 551.072 T.G.C.).
- K. Consultation with Attorney on legal issues pertaining to rule making guidance for Board appointments (Section 551.071 T.G.C.).

ADJOURNMENT OF REGULAR MEETING

CERTIFICATION

I, the Undersigned Authority, do hereby certify that the attached agenda of the Hidalgo County Regional Mobility Authority Board of Directors is a true and correct copy and that I posted a true and correct copy of said notice on the Hidalgo County Regional Mobility Authority Web Page (www.hcrma.net) and the bulletin board in the Hidalgo County Regional Mobility Authority office (203 W. Newcombe Ave, Pharr, Texas 78577), a place convenient and readily accessible to the general public at all times, and said Notice was posted on the 22nd day of **April 2026** at **5:00 pm** and will remain so posted continuously for at least three (3) business days preceding the scheduled day of said meeting in accordance with Chapter 551 of the Texas Government Code.

Maria E. Alaniz
Program Coordinator

Note: If you require special accommodations under the Americans with Disabilities Act, please contact Maria E. Alaniz at 956-402-4762 at least 96 hours before the meeting.

PUBLIC COMMENT POLICY

Public Comment Policy: "At the beginning of each HCRMA meeting, the HCRMA will allow for an open public forum/comment period. This comment period shall not exceed one-half (1/2) hour in length and each speaker will be allowed a maximum of three (3) minutes to speak. Speakers addressing the Board through a translator will be allowed a maximum of six (6) minutes.

All individuals desiring to address the HCRMA must be signed up to do so, prior to the open comment period. For meetings being held by telephonic or videoconference, individuals may contact Maria. E. Alaniz at (956) 402-4762 before 5:00 pm day of the meeting.

The purpose of this comment period is to provide the public an opportunity to address issues or topics that are under the jurisdiction of the HCRMA. For issues or topics which are not otherwise part of the posted agenda for the meeting, HCRMA members may direct staff to investigate the issue or topic further. No action or discussion shall be taken on issues or topics which are not part of the posted agenda for the meeting. Members of the public may be recognized on posted agenda items deemed appropriate by the Chairman as these items are considered, and the same time limitations applies."

Note: Participation by Telephone/Video Conference Call – One or more members of the HCRMA Board of Directors may participate in this meeting through a telephone/video conference call, as authorized by Sec. 370.262, Texas Transportation Code.

Workshop

Item 1

HIDALGO COUNTY REGIONAL MOBILITY AUTHORITY

AGENDA RECOMMENDATION FORM

BOARD OF DIRECTORS	<u> X </u>	AGENDA ITEM	<u> WS1 </u>
PLANNING COMMITTEE	<u> </u>	DATE SUBMITTED	<u> 4/20/2026 </u>
FINANCE COMMITTEE	<u> </u>	MEETING DATE	<u> 4/28/2026 </u>
TECHNICAL COMMITTEE	<u> </u>		

1. Agenda Item: **WORKSHOP ITEM 1 – REVIEW OF FISCAL YEAR 2025 FINANCIAL STATEMENT AND INDEPENDENT AUDITORS REPORT FOR THE HIDALGO COUNTY REGIONAL MOBILITY AUTHORITY.**

2. Nature of Request: (Brief Overview) Attachments: X Yes No

Preview of annual Financial Statement and Independent Auditors Report prepared by Burton McCumber & Longoria, LLP for the Fiscal Year 2025. The report is required by Texas Administrative Code Title 43, Part I, Chapter 26, Subchapter G §26.65(a) Annual Reports to the Commission.

3. Policy Implication: Board Policy, Local Government Code, Texas Government Code, Texas Transportation Code, TxDOT Policy

4. Budgeted: Yes No X N/A

5. Staff Recommendation: **Presentation only.**

6. Program Manager’s Recommendation: Approved Disapproved X None

7. Planning Committee’s Recommendation: Approved Disapproved X None

8. Board Attorney’s Recommendation: Approved Disapproved X None

9. Chief Auditor’s Recommendation: Approved Disapproved X None

10. Chief Financial Officer’s Recommendation: Approved Disapproved X None

10. Chief Development Engineer’s Recommendation: Approved Disapproved X None

11. Chief Construction Engineer’s Recommendation: Approved Disapproved X None

12. Executive Director’s Recommendation: X Approved Disapproved None

THIS ITEM WILL BE
SENT UNDER
SEPERATE COVER

This Page
Intentionally
Left Blank

Workshop

Item 2

HIDALGO COUNTY REGIONAL MOBILITY AUTHORITY

AGENDA RECOMMENDATION FORM

BOARD OF DIRECTORS	<u> X </u>	AGENDA ITEM	<u> WS2 </u>
PLANNING COMMITTEE	<u> </u>	DATE SUBMITTED	<u> 04/20/26 </u>
FINANCE COMMITTEE	<u> </u>	MEETING DATE	<u> 04/28/26 </u>
TECHNICAL COMMITTEE	<u> </u>		

1. Agenda Item: **WORKSHOP ITEM 2 – REVIEW OF FISCAL YEAR 2025 COMPLIANCE REPORT FOR THE HIDALGO COUNTY REGIONAL MOBILITY AUTHORITY.**

2. Nature of Request: (Brief Overview) Attachments: X Yes No

Review of Annual Compliance Report for Fiscal Year 2025. The report is required by Texas Administrative Code Title 43, Part I, Chapter 26, Subchapter G (Regional Mobility Authority and Audits), as amended

3. Policy Implication: Board Policy, Local Government Code, Texas Government Code, Texas Transportation Code, TxDOT Policy

4. Budgeted: Yes No X N/A

5. Staff Recommendation: **Review only.**

6. Program Manager’s Recommendation: Approved Disapproved X None

7. Planning Committee’s Recommendation: Approved Disapproved X None

8. Board Attorney’s Recommendation: Approved Disapproved X None

9. Chief Auditor’s Recommendation: Approved Disapproved X None

10. Chief Financial Officer’s Recommendation: Approved Disapproved X None

11. Development Engineer’s Recommendation: Approved Disapproved X None

12. Construction Engineer’s Recommendation: Approved Disapproved X None

13. Executive Director’s Recommendation: Approved Disapproved X None

Hidalgo County Regional Mobility Authority Compliance Report

Texas Administrative Code Title 43, Part I, Chapter 26, Subchapter G
§26.65(a) Annual Reports to the Commission

Compliance Rule	Compliance Statement	Certification
<i>Rule §26.61 Written Reports:</i>		
The annual operating and capital budgets adopted by the RMA year.	HCRMA is in compliance.	HCRMA adopted the FY 2026 Operating & Capital Budget on December 16, 2025.
Any annual financial information and notices of material events required to be disclosed under Rule 15c2-12 of the SEC.	Not applicable.	
To the extent not disclosed in another report required in this compliance report, a statement of any surplus revenue held by the RMA and a summary of how it intends to use the surplus revenue.	Not applicable. HCRMA does not have surplus revenue at this time.	
An independent auditor's review of the reports of investment transactions prepared under Government Code, §2256.023.	HCRMA is in compliance.	HCRMA Board of Directors accepted the FY 2025 financial statement and independent audit on April 28, 2026, which included a review of investment transactions.
<i>Rule §26.62 Annual Audit:</i>		
The RMA shall maintain its books and records in accordance with generally accepted accounting principles in the United States and shall have an annual financial and compliance audit of such books and records.	HCRMA is in compliance.	HCRMA Board of Directors accepted the FY 2025 financial statement and independent audit on April 28, 2026.
The annual audit shall be submitted to each county or city that is a part of the RMA within 120 days after the end of the fiscal year, and conducted by an independent certified public accountant.	HCRMA is in compliance.	HCRMA has made the financial statement and independent auditors report available to all interested parties.
All work papers and reports shall be retained for a minimum of four years from the date of the audit.	HCRMA is in compliance.	HCRMA's record retention policy in compliance with this requirement.
<i>Rule §26.63 Other Reports to Counties and Cities:</i>		
Provide other reports and information regarding its activities promptly when requested by the counties or cities.	HCRMA is in compliance.	All reports and activities are posted on the HCRMA web site at www.hcrma.net .
<i>Rule §26.64 Operating Records:</i>		
The Department will have access to all operating and financial records of the RMA. The executive director will provide notification if access is desired by the department.	HCRMA is in compliance.	

This Page
Intentionally
Left Blank

Workshop

Item 3

HIDALGO COUNTY REGIONAL MOBILITY AUTHORITY

AGENDA RECOMMENDATION FORM

BOARD OF DIRECTORS	<u> X </u>	AGENDA ITEM	<u> WS3 </u>
PLANNING COMMITTEE	<u> </u>	DATE SUBMITTED	<u> 04/20/2026 </u>
FINANCE COMMITTEE	<u> </u>	MEETING DATE	<u> 04/28/2026 </u>
TECHNICAL COMMITTEE	<u> </u>		

1. Agenda Item: **WORKSHOP ITEM 3 – QUARTERLY INVESTMENT REPORT FOR THE PERIOD ENDING MARCH 31 2026.**

2. Nature of Request: (Brief Overview) Attachments: X Yes No
Presentation of the quarterly investment report.

2. Policy Implication: Board Policy, Local Government Code, Texas Government Code, Public Funds Investment Act Section 2256

4. Budgeted: Yes No X N/A

5. Staff Recommendation: **Report Only.**

6. Planning Committee’s Recommendation: Approved Disapproved X None
7. Board Attorney’s Recommendation: Approved Disapproved X None
8. Chief Auditor’s Recommendation: Approved Disapproved X None
9. Chief Financial Officer’s Recommendation: Approved Disapproved X None
10. Chief Development Engineer’s Recommendation: Approved Disapproved X None
11. Chief Construction Engineer’s Recommendation: Approved Disapproved X None
12. Executive Director’s Recommendation: Approved Disapproved X None



Board of Directors

Robert L. Lozano, Chairman
Juan Carlos Del Ángel, Vice-Chairman
Michael J. Williamson, Secretary/Treasurer
Jose Maria "Joe" Ochoa, Director
Joe Daniel Olivarez, Director
Javier Peña, Director
Nick Rhodes, Director

April 9, 2026

To: Robert L. Lozano, Chairman
Members of the Board of Directors

From: Pilar Rodriguez, Executive Director/Investment Officer

RE: Quarterly Investment Report for Quarter Ending March 31, 2026, Statement of Compliance

The above-referenced report is hereby presented, pursuant to the Public Funds Investment Act (PFIA), for your review and acceptance.

This quarter investment disbursements totaled \$6,785,507 consisting of project construction. Other sources included: net internal transfers totaling \$1,616,486; contributions from (TxDOT Grant)--\$1,667,271; and total interest earned was \$948,426.

The PFIA also requires that the report contains a Statement of Compliance, signed by the Investment Officer, as presented below:

STATEMENT OF COMPLIANCE

This report complies with the requirements of the Public Investment Act as well as the Hidalgo County Regional Mobility Authority's (RMA) adopted investment policy. The RMA follows all provisions of the Public Investment Act and the RMA's investment policy.

Presented by RMA Investment Officers:

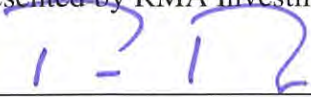

Pilar Rodriguez, Investment Officer



Jose H. Castillo, Investment Officer

HIDALGO COUNTY REGIONAL MOBILITY AUTHORITY
QUARTERLY INVESTMENT SUMMARY REPORT
Quarter Ending March 31, 2026

	<u>Local Govt. Investment Pool</u>	<u>Government (Federated) Securities</u>	<u>Total</u>
COST			
Beginning Balance	\$ 100,447,485	\$ 2,575,596	\$ 103,023,081
Additions:			
Interfund Transfers-in(out)	(1,154,250)	2,770,736	1,616,486
Contributions	-	1,667,271	1,667,271
Investment earnings-LOGIC	922,187	-	922,187
Investment earnings-Wilmington Trust	-	26,239	26,239
Deductions:			
Construction and related expenses	<u>(5,280,514)</u>	<u>(1,504,993)</u>	<u>(6,785,507)</u>
Ending Balance	<u>\$ 94,934,908</u>	<u>\$ 5,534,849</u>	<u>\$ 100,469,757</u>
 MARKET VALUE			
Beginning Balance	<u>\$ 100,466,246</u>	<u>\$ 2,575,596</u>	<u>\$ 103,041,842</u>
Ending Balance	<u>\$ 94,917,333</u>	<u>\$ 5,534,849</u>	<u>\$ 100,452,182</u>
 Weighted Average Maturity- Logic/Gov. Sec.	 47	 30	
Logic/Gov Sec. Weighted Average Yield	3.82%	3.32%	

**HIDALGO COUNTY REGIONAL MOBILITY AUTHORITY
HOLDINGS BY INVESTMENTS
QUARTERLY INVESTMENT REPORT
Quarter Ending March 31, 2026**

Type of Investment	Beginning Cost	Wilmington Interest	LOGIC Interest	Interfund Transfers/ Contributions	Disbursements	Ending Cost	Market Value
Local Govt. Investment Pool:							
Contingency: #2731494001	12,416,482	-	108,397	(1,154,248)	-	11,370,631	11,368,538
Road Maintenance: #2731494002	1,179,635	-	11,144	-	-	1,190,779	1,190,560
Total Local Govt. Investment Pool	\$ 13,596,117	\$ -	\$ 119,541	\$ (1,154,248)	\$ -	\$ 12,561,410	\$ 12,559,098
Government Securities (Federated Govt Obligations):							
General FD #154037-003 & #7731494007	\$ 1,321,533	\$ 3	\$ 12,481	\$ -	\$ -	\$ 1,334,017	1,333,772
Debt Service Fund 2020: #143255-001	475,337	5,230	-	991,488	-	1,472,055	1,472,055
Debt Service Account #154037-001	1,647,950	12,399	-	326,418	-	1,986,767	
Debt Service Account #154038-000	1,031	8	-	-	-	1,039	1,039
Debt Service Account #154038-001	28,489	3,803	-	1,452,830	-	1,485,122	1,485,122
DSRF Account #154037-002 & #7731494006	14,296,474	3	135,055	-	-	14,431,532	14,428,877
DSRF Account #154038-002 & #7731494005	6,447,793	3	60,908	-	-	6,508,704	6,507,506
Disbursement Account: #106912-006 & #7731494008	65,208,357	4,790	594,202	1,667,271	(6,785,507)	60,689,113	60,677,946
Total Government Securities	\$ 89,426,964	\$ 26,239	\$ 802,646	\$ 4,438,007	\$ (6,785,507)	\$ 87,908,349	\$ 85,906,316
Combined Totals	\$ 103,023,081	\$ 26,239	\$ 922,187	\$ 3,283,759	\$ (6,785,507)	\$ 100,469,759	\$ 98,465,415

*Note-Logic interest earned on HCRMA's funds held by Trustee (Wilmington Trust)

**Wilmington Trust Investments Detail Activity
Quarter Ending March 31, 2026**

HIDALGO CO RMA 2020 DS FUND #143255-001

		Income				Disbursements	Ending Balance
		Wilmington Interest	LOGIC Interest	Contributions	Interfund Transfers		
Debt Svc.:	Opening balance:						
January	475,337	886	-	-	330,496	-	806,719
February	806,719	1,715	-	-	330,496	-	1,138,930
March	1,138,930	2,629	-	-	330,496	-	1,472,055
		<u>5,230</u>	<u>-</u>	<u>-</u>	<u>991,488</u>	<u>-</u>	

CONTINGENCY ACCOUNT-LOGIC #2731494001

		Income				Disbursements	Ending Balance
		Wilmington Interest	LOGIC Interest	Contributions	Interfund Transfers		
Contingency:	Opening balance:						
January	12,416,482	-	40,355	-	(1,779,248)	-	10,677,589
February	10,677,589	-	31,937	425,000	-	-	11,134,526
March	11,134,526	-	36,105	200,000	-	-	11,370,631
		<u>-</u>	<u>108,397</u>	<u>625,000</u>	<u>(1,779,248)</u>	<u>-</u>	

ROAD MAINTENANCE ACCOUNT-LOGIC #2731494002

		Income				Disbursements	Ending Balance
		Wilmington Interest	LOGIC Interest	Contributions	Interfund Transfers		
Road Maint.:	Opening balance:						
January	1,179,635	-	3,869	-	-	-	1,183,504
February	1,183,504	-	3,457	-	-	-	1,186,961
March	1,186,961	-	3,818	-	-	-	1,190,779
		<u>-</u>	<u>11,144</u>	<u>-</u>	<u>-</u>	<u>-</u>	

HIDALGO CO RMA DISBURSEMENT ACCT #106912-006 & LOGIC #7731494008

		Income				Disbursements	Ending Balance
		Wilmington Interest	LOGIC Interest	Contributions	Interfund Transfers		
Disbursement:	Opening balance:						
January	65,208,357	1,250	209,854	-	-	(1,356,675)	64,062,786
February	64,062,786	1,202	185,434	1,078,246	-	(2,873,483)	62,454,185
March	62,454,185	2,338	198,914	589,025	-	(2,555,349)	60,689,113
		<u>4,790</u>	<u>594,202</u>	<u>1,667,271</u>	<u>-</u>	<u>(6,785,507)</u>	

HCRMA SR LIEN 2022A DS ACCT. #154037-001

		Income				Disbursements	Ending Balance
		Wilmington Interest	LOGIC Interest	Contributions	Interfund Transfers		
DS Account:	Opening balance:						
January	1,647,950	2,696	-	-	326,418	-	1,977,064
February	1,977,064	4,690	-	-	-	-	1,981,754
March	1,981,754	5,013	-	-	-	-	1,986,767
		<u>12,399</u>	<u>-</u>	<u>-</u>	<u>326,418</u>	<u>-</u>	

**Wilmington Trust Investments Detail Activity
Quarter Ending March 31, 2026**

HCRMA SR LIEN 2022A DSRF #154037-002 & LOGIC #7731494006

DSRF Account:	Opening balance:	Income		Contributions	Interfund Transfers	Disbursements	Ending Balance
		Wilmington Interest	LOGIC Interest				
January	14,296,474	1	46,896	-	-	-	14,343,371
February	14,343,371	1	41,890	-	-	-	14,385,262
March	14,385,262	1	46,269	-	-	-	14,431,532
		<u>3</u>	<u>135,055</u>	<u>-</u>	<u>-</u>	<u>-</u>	

HCRMA JR LIEN 2022B DS ACCT #154038-001

DS Account:	Opening balance:	Income		Contributions	Interfund Transfers	Disbursements	Ending Balance
		Wilmington Interest	LOGIC Interest				
January	28,489	83	-	-	1,452,830	-	1,481,402
February	1,481,402	81	-	-	-	-	1,481,483
March	1,481,483	3,639	-	-	-	-	1,485,122
		<u>3,803</u>	<u>-</u>	<u>-</u>	<u>1,452,830</u>	<u>-</u>	

HCRMA JR LIEN 2022B DSRF #154038-002 & LOGIC #7731494005

DSRF Account:	Opening balance:	Income		Contributions	Interfund Transfers	Disbursements	Ending Balance
		Wilmington Interest	LOGIC Interest				
January	6,447,793	1	21,149	-	-	-	6,468,943
February	6,468,943	1	18,892	-	-	-	6,487,836
March	6,487,836	1	20,867	-	-	-	6,508,704
		<u>3</u>	<u>60,908</u>	<u>-</u>	<u>-</u>	<u>-</u>	

HCRMA JR LIEN REV BDS 2022B #154038-000

Rev Bds 2022B	Opening balance:	Income		Contributions	Interfund Transfers	Disbursements	Ending Balance
		Wilmington Interest	LOGIC Interest				
January	1,031	3	-	-	-	-	1,034
February	1,034	3	-	-	-	-	1,037
March	1,037	2	-	-	-	-	1,039
		<u>8</u>	<u>-</u>	<u>-</u>	<u>-</u>	<u>-</u>	

HCRMA SR LIEN 2022A GENERAL FD #154037-003 & LOGIC #7731494007

General FD Account	Opening balance:	Income		Contributions	Interfund Transfers	Disbursements	Ending Balance
		Wilmington Interest	LOGIC Interest				
January	1,321,533	1	4,333	-	-	-	1,325,867
February	1,325,867	1	3,872	-	-	-	1,329,740
March	1,329,740	1	4,276	-	-	-	1,334,017
		<u>3</u>	<u>12,481</u>	<u>-</u>	<u>-</u>	<u>-</u>	

This Page
Intentionally
Left Blank

Workshop

Item 4

HIDALGO COUNTY REGIONAL MOBILITY AUTHORITY

AGENDA RECOMMENDATION FORM

BOARD OF DIRECTORS	<u> X </u>	AGENDA ITEM	<u> WS4 </u>
PLANNING COMMITTEE	<u> </u>	DATE SUBMITTED	<u> 4/20/2026 </u>
FINANCE COMMITTEE	<u> </u>	MEETING DATE	<u> 4/28/2026 </u>
TECHNICAL COMMITTEE	<u> </u>		

1. Agenda Item: **WORKSHOP ITEM 4 – RIO GRANDE VALLEY METROPOLITAN ORGANIZATON PRESENTATION.**

2. Nature of Request: (Brief Overview) Attachments: X Yes No
Presentation by the Rio Grande Valley Metropolitan Organization.

3. Policy Implication: Board Policy, Local Government Code, Texas Government Code, Texas Transportation Code, TxDOT Policy

4. Budgeted: Yes No X N/A

5. Staff Recommendation: **Presentation only.**

6. Program Manager’s Recommendation: Approved Disapproved X None

7. Planning Committee’s Recommendation: Approved Disapproved X None

8. Board Attorney’s Recommendation: Approved Disapproved X None

9. Chief Auditor’s Recommendation: Approved Disapproved X None

10. Chief Financial Officer’s Recommendation: Approved Disapproved X None

10. Chief Development Engineer’s Recommendation: Approved Disapproved X None

11. Chief Construction Engineer’s Recommendation: Approved Disapproved X None

12. Executive Director’s Recommendation: X Approved Disapproved None

Hidalgo County Regional Mobility Authority



April 28, 2026



Presentation Overview

- About RGVMPO
- Major Planning Documents
- Project Funding
- 10-year plan "Histography"
- Leveling Effort: Balancing the "10-Year Plan"
- Project Readiness Report
- Electronic Project Request Form
- Northern Relief Route
- HC West Loop Planning and Environmental Linkages Study



About RGVMPO

- The RGVMPO is the federally recognized transportation planning organization responsible for coordinating and managing federally funded transportation projects across all modes in the Rio Grande Valley.
- Represents Cameron County, Hidalgo County, and part of Starr County.
- The Transportation Policy Board (TPB) is the decision-making body of the RGVMPO, ensuring that all regional transportation studies, plans, and projects:
 - The Technical Advisory Committee reviews technical matters and develops preferred technical alternatives and recommendations for TPB approval.

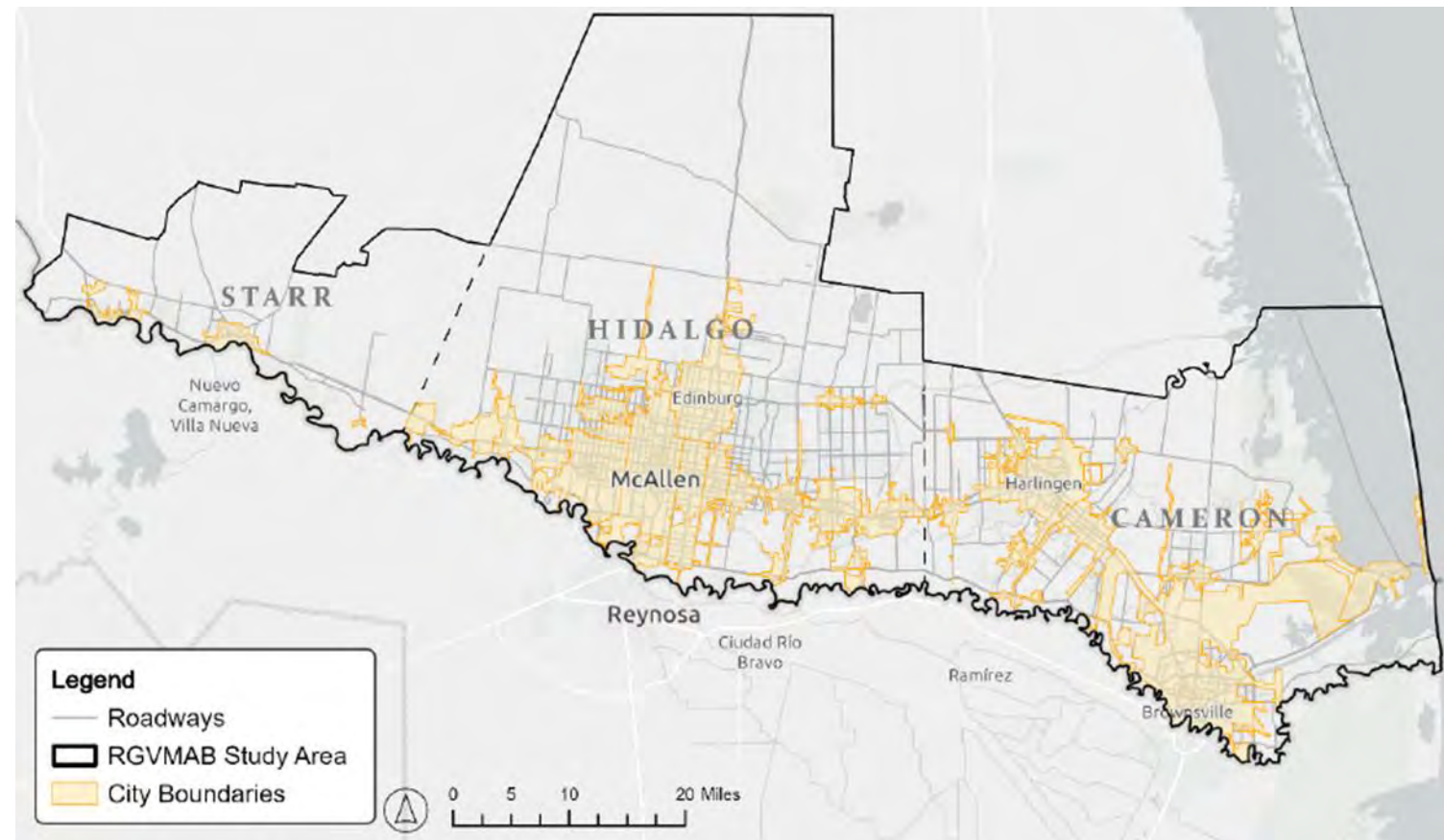

Source: RGVMPO 2050 MTP



Major Planning Documents

Federally required documents as per 23 CFR § 450;

Unified Planning Work Program (UPWP):

- Serves as the 2-year transportation planning work program outlining the transportation planning, programs, and activities to be performed in the region. **Approved July 21, 2025.**

Metropolitan Transportation Plan (MTP):

- Long-range transportation planning document that serves as a blueprint for the next 25 years. It identifies needs, establishes priorities for funding, and outlines strategies. **Approved December 5, 2025.**

Transportation Improvement Program (TIP):

- Short-range planning document that identifies construction projects. Contains programmed dollars for all projects for all programs including roadway, transit, and active transportation. **Approved December 5, 2025.**

Public Participation Plan (PPP):

- Serves as a program guide for the public participation process. Defines policies and principles for communication and coordination with interested parties. **Approved July 21, 2025.**

Congestion Management Process (CMP):

- Identifies, analyzes, and monitors traffic congestion and provides strategies to improve the efficiency and performance of the regional transportation network. **Approved October 30, 2024.**



Project Funding

UTP

The Unified Transportation Program is TxDOT's 10-year plan.

On average, the UTP allocates \$32.4M in Category 7 annually.

MTP

Highway
~ \$7B

Transit
~\$138 M

TIP

Highway
~ \$1.2B

Transit
~\$138M

Category 7: Metropolitan Mobility and Rehabilitation: addresses transportation needs within the boundaries of MPOs with populations of 200,000 or greater – known as TMAs .

- This funding can be used on any roadway with a functional classification greater than a local road or rural minor collector.
- Common project types include roadway widening (both freeway and non-freeway), new-location roadways and interchange improvements.



10-year plan's "histography"

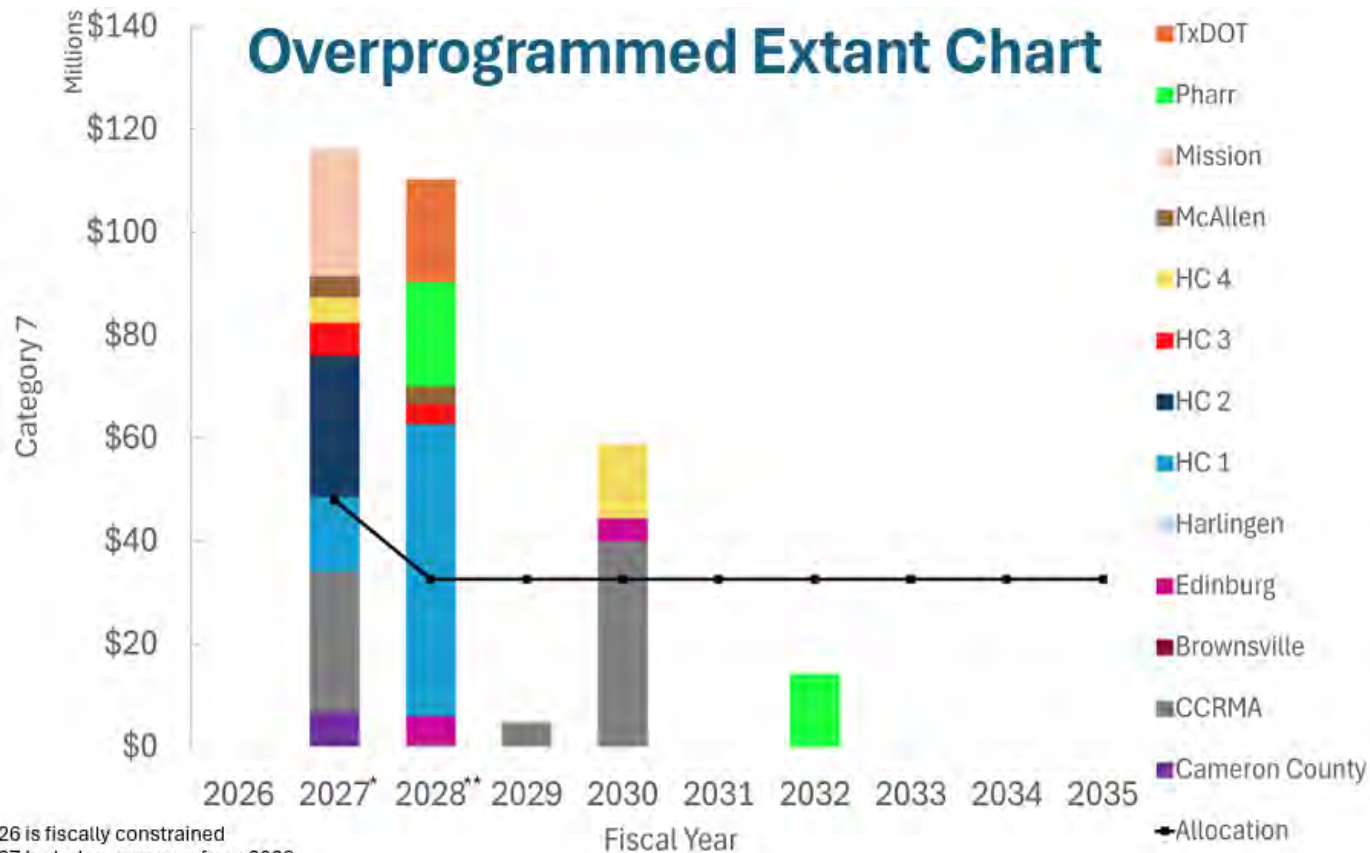

A leveling effort was implemented to balance the 10-Year Plan, ensuring it remains financially constrained and fully compliant with federal requirements.

- For example, FY 2028 was overprogrammed by \$77,548,164 in comparison to the FY 2028 UTP projected funding of \$32,565,401.



Leveling Effort: Balancing the 10 Year Plan

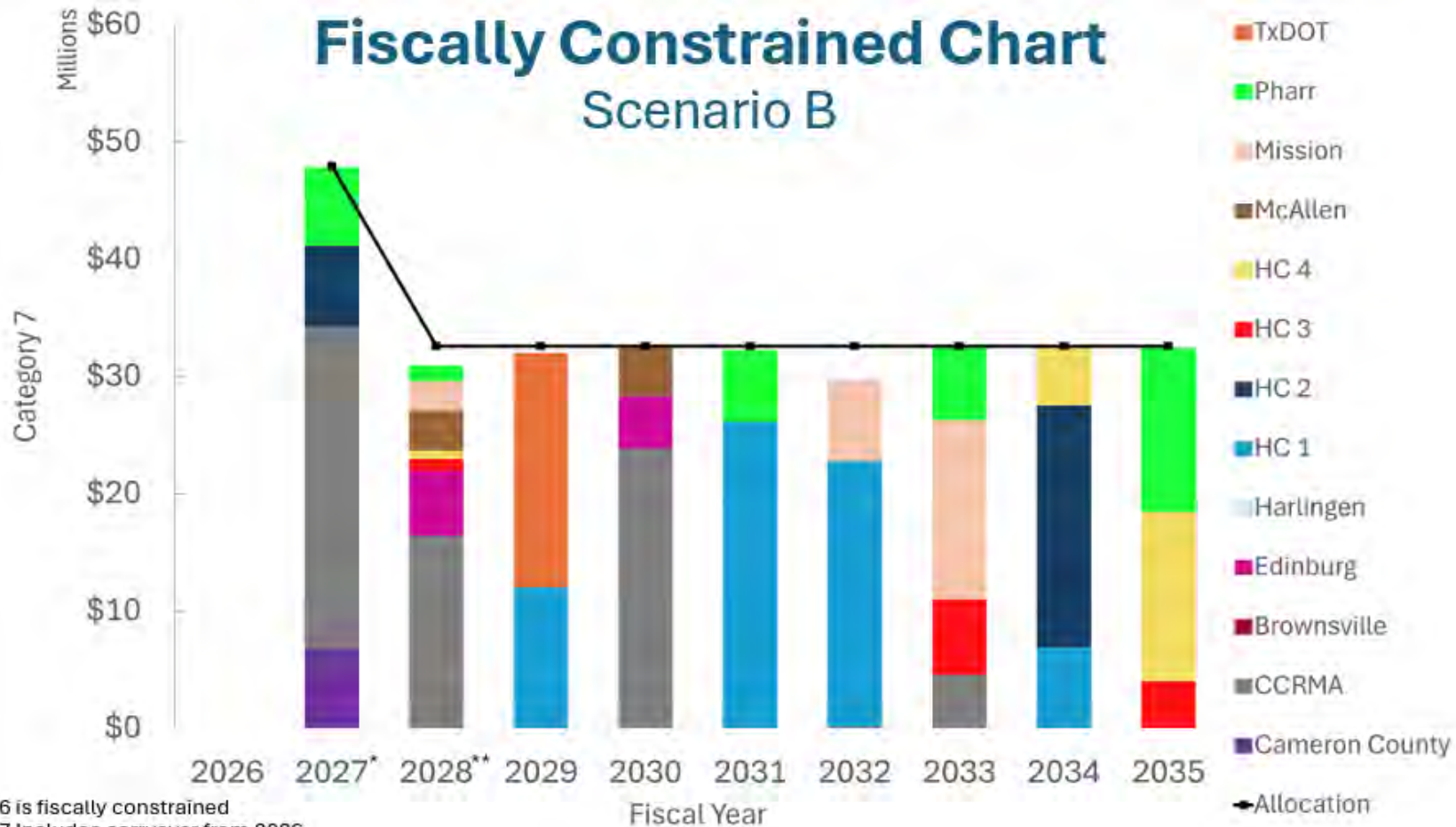

Fiscally constrained Scenario B was adopted by the TPB via Resolution 2025-12 on September 24, 2025, in accordance with 23 CFR §450.324(f)(11)(i)(1) and §450.326(g).

Establishing that candidate projects shall be programmed in the 10-Year Plan based on project **readiness** and **financial capacity** within the applicable fiscal year.



Project Readiness Report

DRAFT

As of April 9th, 2026

Project Readiness Report (PRR)

FHWA, State, & Local Funds (CAT 7 Highway)

#	CSJ	Programmed Fiscal Year	ROW FPAA or Construction Est. Let Date	Initial Federal Funding Approval Date	Project Information							Funding Amount		Alerts	AFA	Preliminary Engineering		ROW/Utilities		Railroad Coordination ⁵	Sponsor Contact (RPIC) Local PM Contact State PM Contact	Comments
					Project Name	From	To	Project Description	Project Sponsor	g/I ⁶	Phase	CAT	Programmed			ENV ¹	PS&E % ²	ROW ³	Utilities ⁴			
1	0921-02-286	2025	5/3/2021	PE/ROW: Sept. 2015	Mile 6 W.	SH 107	Mile 11 N	ROW Acquisition for RECONST. & Widen from 2 to 4 Lanes	HC 1	e	R	7	\$4,396,313		8/20/2020	12/16/2015	No	40/152	No		David Suarez, HC PCT 1, RPIC Jordan Sinclair, L&G PM Francisco Chapa, TxDOT PM	ROW: 112 parcels needed Subordinate CSJ:0921-02-560 Pending AFA for CAT 9
2	0921-02-399	2025	1/5/2022	ROW: Sept. 2018 CONST: Aug. 2024	Cesar Chavez (Sec. I)	Business 83	Ridge Rd.	Widen from 2 to 4 lanes	HC 2	e	R	7	\$1,000,000		5/23/2025	Cleared 2/17/2026 2/17/2021	95%	9/16	No		Erika Zamora, HC PCT 2, RPIC Robert Macheska, PM Francisco Chapa, TxDOT PM	ROW: Proceed issued 3/29/2022, 16 parcels: 9 in possession, 7 in closing. UTL: 0 of 6 Anticipated adjustment completion by April 2026 RR: Will need a RR Packet due to proximity Subordinate CSJ:0921-02-559 Pending AFA for CAT 9
3	0921-02-405	2025	4/26/2022	ROW: Sept. 2018 CONST: Aug. 2024	Cesar Chavez (Sec. II)	Business 83	Nolana Loop	Widen from 2 to 4 lanes	HC 2	e	R	7	\$4,570,000		5/27/2025	Cleared 2/17/2026 2/17/2021	30%	27/82	No	RR	Erika Zamora, HC PCT 2, RPIC Armando I. Sandoval, L&G PM Francisco Chapa, TxDOT PM	ROW: Proceed issued 5/13/2022, 82 parcels: 27 in poss., 3 in appraisal, 9 in neg, 16 in closing, 19 in ED, 8 eliminated UTL: Pending ROW, Certifications anticipated Feb. 2030 RR: UPRR requesting 3 closures to approve proposed proj Subordinate CSJ:0921-02-562 Pending AFA for CAT 9
4	0921-02-321	2025	3/17/2020	ROW: Sept. 2018 CONST: Aug. 2024	Liberty Blvd. (Ph. II)	FM 2221	Mile 3 Rd.	New Location (from Mile 4 to FM 2221) and reconstruction of existing roadway to a 2 lane rural facility with shoulders	HC 3	e	R	7	\$2,030,000		10/3/2023	Cleared 9/29/2015	100%	36/39	No		Jorge Arcuate, HC PCT 3, RPIC Jordan Sinclair, L&G PM Griselda Saldivar, TxDOT PM	ROW: 3 in ED. Anticipated by 5/28/25 UTL: Anticipated by 5/25/25 CONST: Potential for Advance Construction UPDATE: Let and Pending Bid Analysis
5	0921-02-321	2025	4/11/2025	ROW: Sept. 2018 CONST: Aug. 2024	Liberty Blvd.	FM 2221	Mile 3	Construct 2 lane roadway with shoulders (on existing roadway from Mile 3 to Mile 4, on new location from Mile 4 to FM 2221)	HC 3	i	C,E	7	\$10,875,384		10/3/2023	Cleared 9/29/2015	100%	36/39	No		Jorge Arcuate, HC PCT 3, RPIC Jordan Sinclair, L&G PM Griselda Saldivar, TxDOT PM	ROW: 3 in ED. Anticipated by 5/28/25 UTL: Anticipated by 5/25/25 UPDATE: Let and Pending Bid Analysis
6	0921-02-328	2025	8/1/2018	ROW: Oct. 2015 CONST: June 2015	Taylor Rd.	Mile 2 N	Business 83	Widen from 2 lanes to 4 lane divided urban	Mission	e	R	7	\$2,011,852		8/15/2023	Cleared 6/2018 6/2022	100%	67/69	No	Complete	Juan P. Terrazas, Mission, RPIC Armando Sandoval, L&G PM Ana Pruneda, TxDOT PM	ROW: 2 parcels in Neg./ED FPAA received 8/1/2018 UTL: Est. complete May 2025 UPDATE: Let and Pending Bid Analysis
7	0921-02-328	2025	4/16/2025	ROW: Oct. 2015 CONST: June 2015	Taylor Rd.	Mile 2 N	Business 83	Widen from 2 to 4 lanes divided urban	Mission	i	C,CE	7	\$13,487,802		8/15/2023	Cleared 6/2018 6/2022	100%	67/69	No	Complete	Juan P. Terrazas, Mission, RPIC Armando Sandoval, L&G PM Ana Pruneda, TxDOT PM	ROW: 2 parcels in Neg./ED UTL: Est. complete May 2025 FPAA received 4/16/2025 UPDATE: Let and Pending Bid Analysis
8	0921-02-403	2026	10/15/2020	ROW: Sept. 2018 CONST: Aug. 2024	Eldora Rd.	FM 3362 (Jackson Rd)	Veterans Blvd (I Rd)	Widen from 2 to 4 Lane Divided	HC 2	e	R	7	\$1,200,000		10/9/2025	Cleared 4/25/2025 4/10/2020	100%	100%	No		Erika Zamora, HC PCT 2, RPIC Reza Badiozamani, L&G PM Francisco Chapa, TxDOT PM	ROW: Proceed issued 11/22/2020, all 45 parcels acquired. UTL: Adjustments in progress. 2 of 7 complete. Est. April '26
9	0921-02-403	2026	5/1/2026	ROW: Sept. 2018 CONST: Aug. 2024	Eldora Rd.	FM 3362 (Jackson Rd)	Veterans Blvd (I Rd)	Widen from 2 to 4 lanes divided	HC 2	i	C,CE	7	\$14,282,559		10/9/2025	Cleared 4/25/2025 4/10/2020	100%	100%	No		Erika Zamora, HC PCT 2, RPIC Reza Badiozamani, L&G PM Francisco Chapa, TxDOT PM	ROW: Proceed issued 11/22/2020, all 45 parcels acquired. UTL: Adjustments in progress. 2 of 7 complete. Est. April '26 FPAA Requested 3/11/26
10	0921-06-378	2026	5/1/2026	CONST: Oct. 2024	Old Alice Road Sidewalks	SH 100	Sports Park Blvd	8 ft. wide sidewalks and signage/signal improvements with median/safety refuge/island at SH550 underpass	Cameron County	e	C,CE	7	\$1,633,849		3/26/2025	Cleared 3/17/26	100%	100%	No		Ben Worsham, Cameron Co. RPIC Eric Davila, CCRMA PM	Project planned to let with Old Alice Rd (0921-06-290) AFA amendment #1 executed.



Scan to view the most recently approved PRR!





The Electronic Project Request Form, project schedule, financial summary, and resolutions feed into the development of the Project Readiness Report.

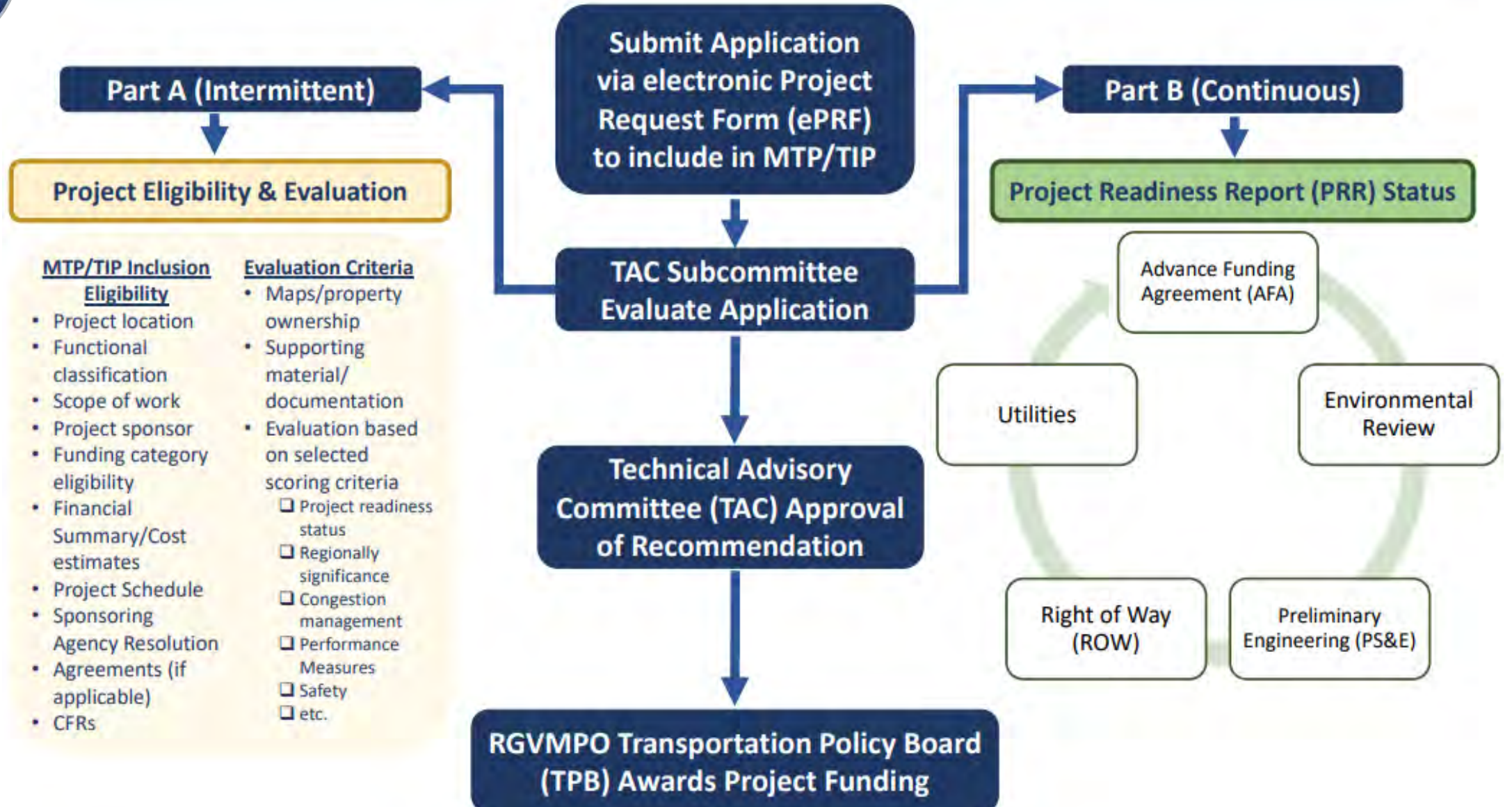



Northern Relief Route

State Loop 195 Starr County



Source: [TxDOT SL 195 Fact Sheet](#)

I-69 Connector Hidalgo County



Source: [I-69 TxDOT Scoping Meeting](#)

Outer Parkway Cameron County

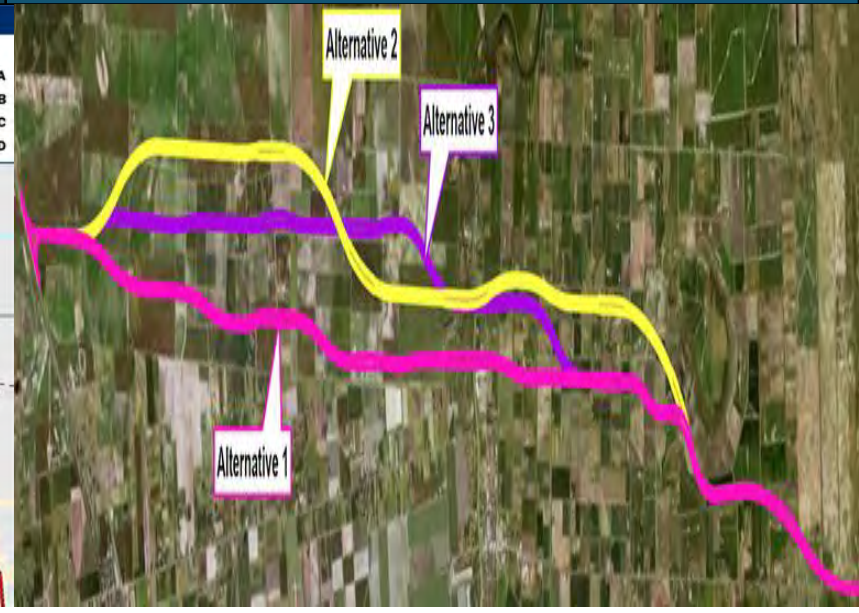

Source: [CCRMA Outer Parkway NOC](#)



HC West Loop PEL Study

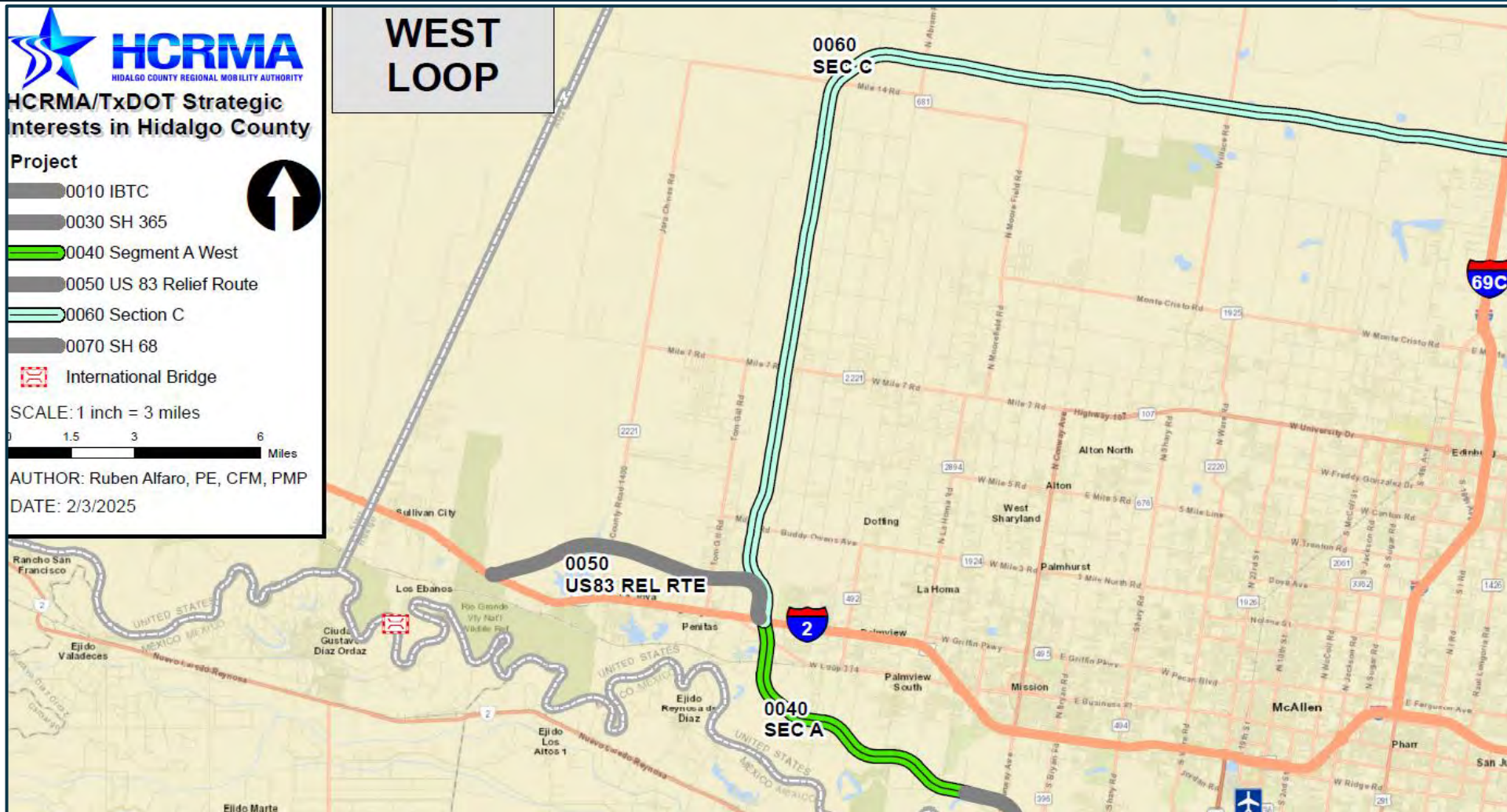

This Planning Environmental Linkages study will gather comprehensive data about the proposed West Loop, identify and evaluate potential route alternatives, and determine required environmental procedures and compliance measures.

Scan the QR code to view our MTP!



Thank You!

Contact us:

Email

info@rgvmpo.org

Website

www.rgvmpo.org

Phone

(956)682-3481

Address

617 W. University
Drive, Edinburg,
TX 78539

Item 1

HIDALGO COUNTY REGIONAL MOBILITY AUTHORITY

AGENDA RECOMMENDATION FORM

BOARD OF DIRECTORS	<u> X </u>	AGENDA ITEM	<u> 1A </u>
PLANNING COMMITTEE	<u> </u>	DATE SUBMITTED	<u> 04/20/2026 </u>
FINANCE COMMITTEE	<u> </u>	MEETING DATE	<u> 04/28/2026 </u>
TECHNICAL COMMITTEE	<u> </u>		

1. Agenda Item: **CHAIRMAN’S REPORT.**

2. Nature of Request: (Brief Overview) Attachments: Yes No
Chairman’s Report

3. Policy Implication: Board Policy, Local Government Code, Texas Government Code, Texas Transportation Code, TxDOT Policy

4. Budgeted: Yes No N/A

5. Staff Recommendation: **Report only.**

6. Program Manager’s Recommendation: Approved Disapproved None

7. Planning Committee’s Recommendation: Approved Disapproved None

8. Board Attorney’s Recommendation: Approved Disapproved None

9. Chief Auditor’s Recommendation: Approved Disapproved None

10. Chief Financial Officer’s Recommendation: Approved Disapproved None

11. Development Engineer’s Recommendation: Approved Disapproved None

12. Chief Construction Engineer’s Recommendation: Approved Disapproved None

13. Executive Director’s Recommendation: Approved Disapproved None

HIDALGO COUNTY REGIONAL MOBILITY AUTHORITY

CHAIRMAN'S REPORT Tuesday, April 28, 2026

- A. Western Hidalgo County Loop System Development.
- B. Status Reports from Administration, Project, and Revenue Committees

This Page
Intentionally
Left Blank

Item 2A

HIDALGO COUNTY REGIONAL MOBILITY AUTHORITY

AGENDA RECOMMENDATION FORM

BOARD OF DIRECTORS	<u> X </u>	AGENDA ITEM	<u> 2A </u>
PLANNING COMMITTEE	<u> </u>	DATE SUBMITTED	<u> 04/20/2026 </u>
FINANCE COMMITTEE	<u> </u>	MEETING DATE	<u> 04/28/2026 </u>
TECHNICAL COMMITTEE	<u> </u>		

1. Agenda Item: **REPORT ON PROGRAM MANAGEMENT ACTIVITY FOR 365 TOLLWAY PROJECT AND HIDALGO COUNTY REGIONAL MOBILITY AUTHORITY PROJECTS**

2. Nature of Request: (Brief Overview) Attachments: Yes No
Report on Overweight Permits Activity, briefing on development activities.

3. Policy Implication: Board Policy, Local Government Code, Texas Government Code, Texas Transportation Code, TxDOT Policy

4. Budgeted: Yes No N/A

5. Staff Recommendation: **Report Only**

6. Program Manager's Recommendation: Approved Disapproved None

7. Planning Committee's Recommendation: Approved Disapproved None

8. Board Attorney's Recommendation: Approved Disapproved None

9. Chief Auditor's Recommendation: Approved Disapproved None

10. Chief Financial Officer's Recommendation: Approved Disapproved None

10. Chief Development Engineer's Recommendation: Approved Disapproved None

11. Chief Construction Engineer's Recommendation: Approved Disapproved None

12. Executive Director's Recommendation: Approved Disapproved None



HCRMA Board of Directors

Robert L. Lozano, Chairman

Juan Carlos Del Angel, Vice-Chairman

Michael J. Williamson, Secretary/Treasurer

Jose Maria "Joe" Ochoa, Director

Joe Olivarez, Director

Javier Peña, Director

Nick Rhodes, Director

HCRMA Administrative Staff

Pilar Rodriguez, PE, Executive Director

Ramon Navarro IV, PE, CFM, Chief Constr. Eng.

Celia Gaona, CIA, Chief Auditor/Compliance Ofcr.

Jose Castillo, Chief Financial Ofcr.

Ruben Alfaro, PE, CFM, PMP, Development Engineer

General Engineering Consultant
HDR ENGINEERING, INC.

Report on HCRMA Development Activities

Ruben Alfaro, PE, CFM, PMP
Development Engineer



Overview

- Overweight Permit Summary
- Development Updates

MISSION STATEMENT:

To provide our customers with a rapid and reliable alternative for the safe and efficient movement of people, goods, and services.



MONTHLY OVERWEIGHT REPORT:

March 1, 2026 – March 31, 2026

	Current Year	2025	% CHANGE
Total Permits Issued:	6,858	6,562	4.51%
Total Amount Collected:	\$ 1,440,625.98	\$ 1,339,826.00	7.52%
■ Convenience Fees:	\$ 27,877.98	\$ 27,426.00	
■ Total Permit Fees:	\$ 1,412,748.00	\$ 1,312,400.00	
– Pro Miles:	\$ 20,574.00	\$ 19,686.00	
– TxDOT (On system):	\$ 1,200,835.80	\$ 1,100,119.30	
– Local (Off system):	\$ -	\$ 15,420.70	
– HCRMA:	\$ 191,338.20	\$ 177,174.00	7.99%

Effective January 1, 2026, permit fee increased from \$200 to \$206

Convenience fees: 3% of Credit Card Payment

Pro Miles: \$3 per Permit.

TxDOT & Local: 85% of Total Permit fees.

HCRMA: Remaining of Total Permit fees.



Permit Totals by Month (2023–2026)

Overweight/Oversized Permit Count
2023 - 2026 Monthly Comparison

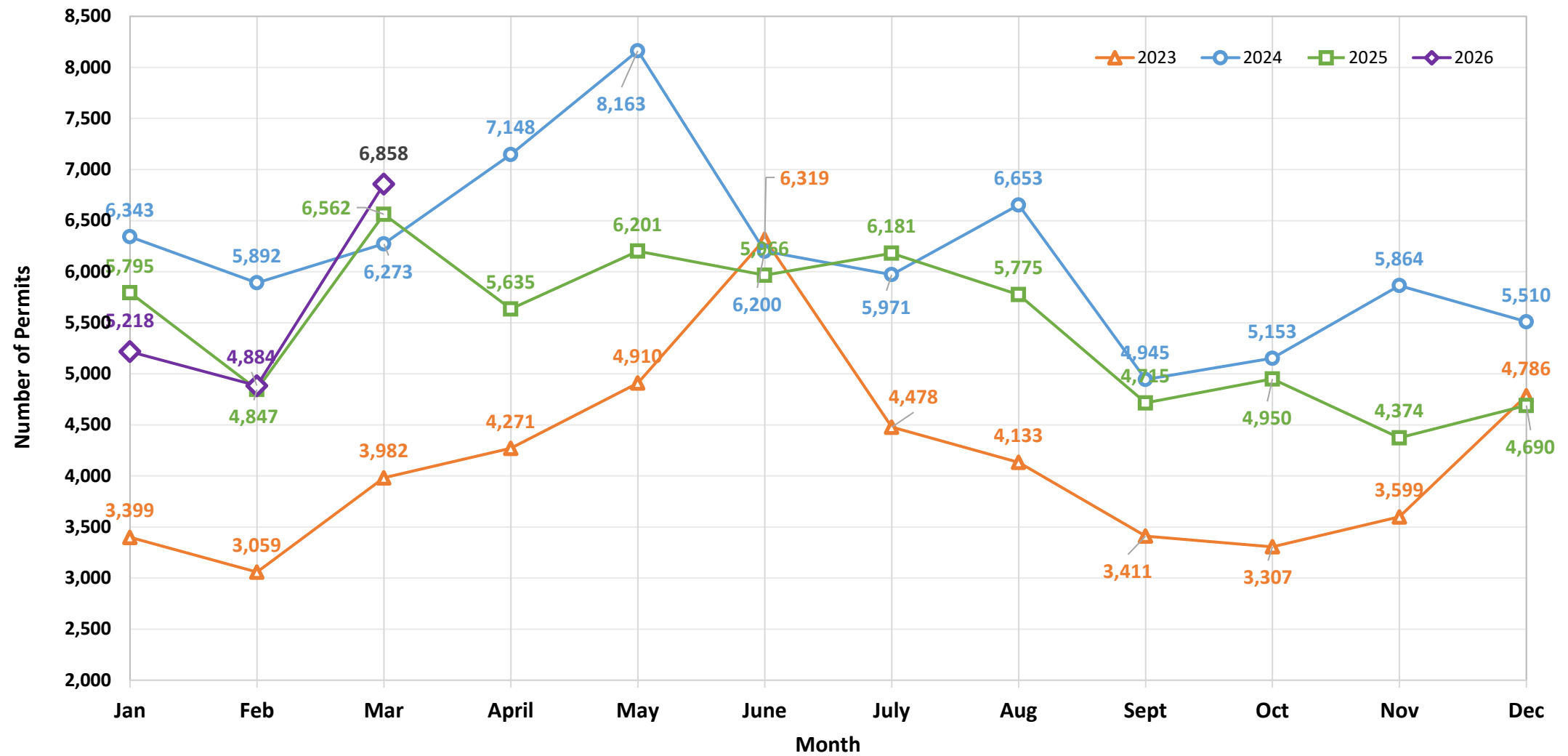

Current Year	2025	% CHANGE
Total Amount Collected	\$ 3,560,263.16	\$ 3,515,752.00 1.27%
Convenience Fees	\$ 68,021.16	\$ 74,952.00
Total Permit Fees	\$ 3,492,242.00	\$ 3,440,800.00
Pro Miles	\$ 50,880.00	\$ 51,612.00
TxDOT (On system)	\$ 2,968,405.70	\$ 2,884,250.60
Local (Off system)	\$ -	\$ 40,429.40
HCRMA	\$ 472,956.30	\$ 464,508.00 1.82%

YEARLY OVERWEIGHT REPORT:

January 1, 2026 – March 31, 2026

	Current Year	2025	% CHANGE
Total Permits Issued:	16,960	17,204	-1.42%
Total Amount Collected:	\$ 3,560,263.16	\$ 3,515,752.00	1.27%
■ Convenience Fees*:	\$ 68,021.16	\$ 74,952.00	
■ Total Permit Fees:	\$ 3,492,242.00	\$ 3,440,800.00	
– Pro Miles:	\$ 50,880.00	\$ 51,612.00	
– TxDOT (On system):	\$ 2,968,405.70	\$ 2,884,250.60	
– Local (Off system):	\$ -	\$ 40,429.40	
– HCRMA:	\$ 472,956.30	\$ 464,508.00	1.82%

Effective January 1, 2026, permit fee increased from \$200 to \$206

Convenience fees: 3% of Credit Card Payment

Pro Miles: \$3 per Permit.

TxDOT & Local: 85% of Total Permit fees.

HCRMA: Remaining of Total Permit fees.



Cumulative Permit Totals by Month (2023–2026)

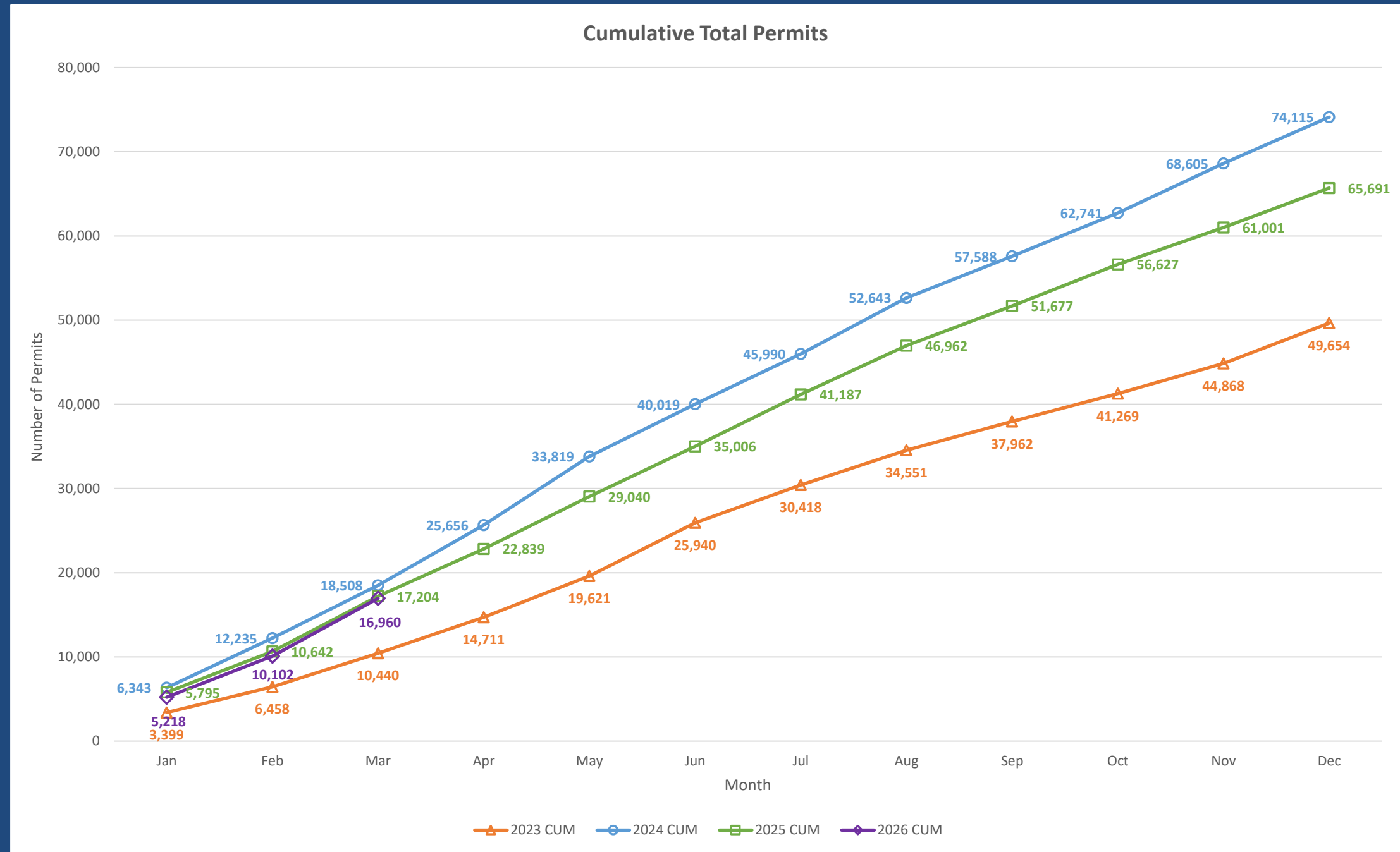

ACCUMULATED OVERWEIGHT REPORT:

January 1, 2014 – March 31, 2026

Total Permits Issued:	471,474
Total Amount Collected:	\$ 85,203,431.16
■ Convenience Fees:	\$ 1,702,301.40
■ Total Permit Fees:	\$ 83,501,129.76
– Pro Miles:	\$ 1,388,592.00
– TxDOT (On system):	\$ 70,780,685.31
– Local (Off system):	\$ 153,497.30
– HCRMA:	\$ 11,178,355.50



DEVELOPMENT UPDATES:

- Completed Base Fee negotiations with Consor Engineers for Segments A, C, E and F. Scoping and schedule meetings are underway.

PUBLIC OUTREACH:

- P3 Conference Dallas, TX (March 23 - 25, 2026)
- 2027 Texas Freight Mobility Plan Workshop (April 8, 2026)



Item 2B

HIDALGO COUNTY REGIONAL MOBILITY AUTHORITY

AGENDA RECOMMENDATION FORM

BOARD OF DIRECTORS	<u> X </u>	AGENDA ITEM	<u> 2B </u>
PLANNING COMMITTEE	<u> </u>	DATE SUBMITTED	<u> 4/20/2026 </u>
FINANCE COMMITTEE	<u> </u>	MEETING DATE	<u> 4/28/2026 </u>
TECHNICAL COMMITTEE	<u> </u>		

1. Agenda Item: **REPORT ON CONSTRUCTION ACTIVITY FOR THE 365 TOLLWAY PROJECT.**

2. Nature of Request: (Brief Overview) Attachments: X Yes No
Report on 365 Tollway Project Construction Activities.

3. Policy Implication: Board Policy, Local Government Code, Texas Government Code, Texas Transportation Code, TxDOT Policy

4. Budgeted: Yes No X N/A

5. Staff Recommendation: **Report only.**

6. Program Manager's Recommendation: Approved Disapproved X None
7. Planning Committee's Recommendation: Approved Disapproved X None
8. Board Attorney's Recommendation: Approved Disapproved X None
9. Chief Auditor's Recommendation: Approved Disapproved X None
10. Chief Financial Officer's Recommendation: Approved Disapproved X None
10. Chief Development Engineer's Recommendation: Approved Disapproved X None
11. Chief Construction Engineer's Recommendation: X Approved Disapproved None
12. Executive Director's Recommendation: Approved Disapproved X None



HCRMA
HIDALGO COUNTY REGIONAL MOBILITY AUTHORITY

BOARD OF DIRECTORS MEETING FOR APRIL 2026

HCRMA Board of Directors

Robert L. Lozano, Chairman

Juan Carlos Del Ángel, Vice-Chairman

Michael J. Williamson, Secretary/Treasurer

Jose Maria “Joe” Ochoa, Director

Joe Daniel Olivarez, Director

Javier Peña, Director

Nick Rhodes, Director

HCRMA Administrative Staff

Daniel Garcia, PE, Executive Director

Ramon Navarro IV, PE, CFM, Chief Constr. Eng.

Ruben Alfaro, PE, Development Eng.

Celia Gaona, CIA, Chief Auditor/Compliance Ofcr.

Jose Castillo, Chief Financial Ofcr.

General Engineering Consultant

HDR Engineering Inc.

www.hcrma.net

Report on HCRMA Construction Activity
Chief Construction Engineer – Ramon Navarro IV, PE, CFM



- ❑ 365 Toll Intergration Project
- ❑ 365 Tollway Civil Project

MISSION STATEMENT:

To provide our customers with a rapid and reliable alternative for the safe and efficient movement of people, goods, and services.



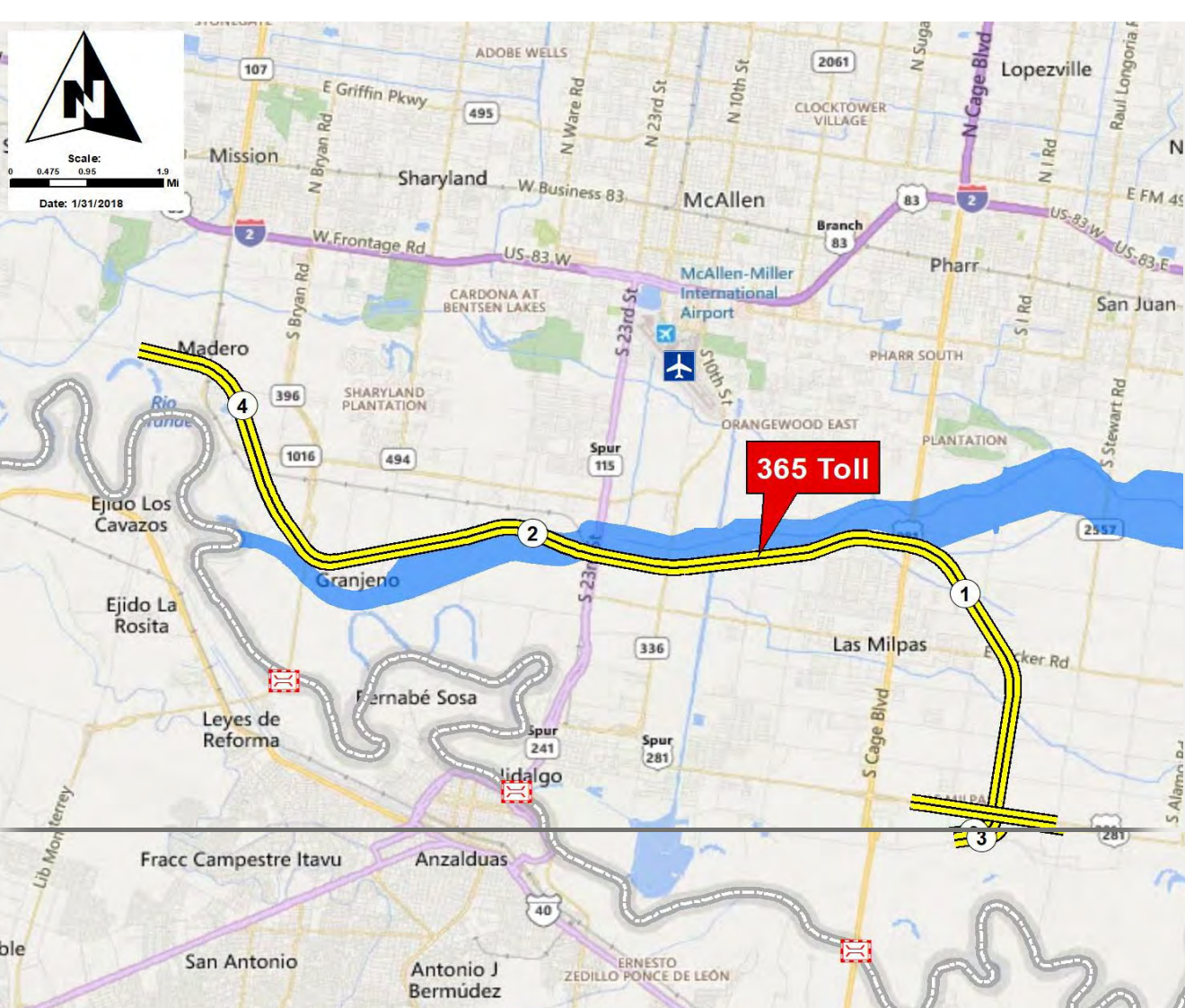

MAJOR MILESTONES:

NEPA
CLEARANCE
07/03/2015

PH 1: 365 SEG. 3 –
LET: 08/2015
COMPLETED

PH 2: 365 TOLL
SEGS. 1 & 2 –
LET: 11/2021

OPEN: 01/2026

365 TOLL SEGS. 1 & 2 LIMITS FROM FM 396 / ANZ. HWY.
TO US 281 / BSIF CONNECTOR (365 SEG. 3)
365 TOLL SEG. 4 LIMITS FROM FM 1016 / CONWAY AVE
TO FM 396 / ANZ. HWY. (FUTURE CONSTRUCTION)

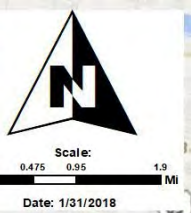
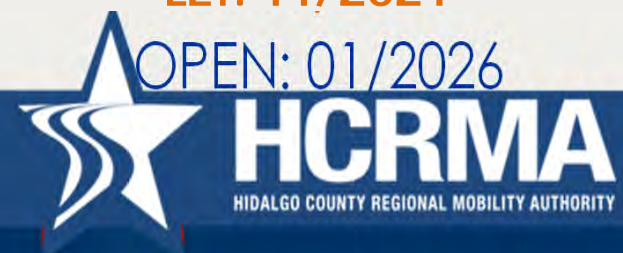



365 TOLLWAY COLLECTION SYSTEM INSTALLATION, INTEGRATION & MAINTENANCE PROJECT



365 Tollway Implementation Board Progress Report

HIDALGO COUNTY REGIONAL MOBILITY AUTHORITY
203 W. Newcombe Ave Pharr, Texas 78577



April 28, 2026

Project Background

365 Tollway – Toll System Integration

Project Description

The Toll System Integration project includes the preliminary design, final design, development, deployment, testing, and commissioning of the 365 Toll System.

- 4 Mainline Gantries
- 5 Ramp Gantries
- Roadside Collection System
- Commercial Back-Office System
- Integration with third-party back-office and customer service center (HCTRA/CCRMA) for revenue collection



Toll System Integrator responsible for:

- Development, implementation, and testing
- Operations & Maintenance
- Roadside Equipment
- Operational Back Office



Tolling Consultant responsible for:

- Preliminary Design
- Oversight of final design, development and testing
- Cost estimates and toll system cash flow forecasting
- Training and development of HCRMA staff

Project Background

365 Tollway – Toll System Integration

Contract Status

- SICE Tolling
 - Competitive bid process with 5 proposers
 - Lowest bid **and** Highest Value
- Notice to Proceed: July 6, 2023

Cost	Original Contract	Current Contract
Capital Cost	\$8,228,923.00	\$8,874,094.00
Operations (5 yrs)	\$5,751,746.00	\$5,751,746.00
Total Cost	\$13,980,669.00	\$14,625,840.00

- Cost to-Date: \$4.7M (53% of capital cost)

Change Orders

Change Order 1

- Mono-Gantry Solution and Large Truck Classification
- Reduce infrastructure and increase revenue
- Cost: \$645,171

Change Order 2

- Modified Go-Live Date
- Implement Soft-Go-Live three months early
- Cost: Under Review



SICE INC. - CONSTRUCTION PHASE

Contract Amount **\$8,874,094.17**

Invoice Number	Date	365 Toll Collection System Installation Integration	Billing Amount	Retainage	Invoice Amount	Percentage %
365TCS- INV-0001	8/1/2023	Contract Signature & Performance Bond, Monthly Mgmt. Fee, and Delivery of Payment & Performance Bond	\$ 734,715.04	\$ (73,471.50)	\$ 661,243.54	7.45%
365TCS- INV-0002	9/1/2023	Milestone Draw Request	\$ 197,153.58	\$ (19,715.36)	\$ 177,438.22	2.00%
365TCS-INV-0003	10/1/2023	Milestone Draw Request	\$ 223,885.56	\$ (22,388.56)	\$ 201,497.00	2.27%
365TCS-INV-0004	11/1/2023	Milestone Draw Request	\$ 157,550.80	\$ (15,755.08)	\$ 141,795.72	1.60%
365TCS-INV-0005	12/1/2023	Milestone Draw Request	\$ 38,742.00	\$ (3,874.20)	\$ 34,867.80	0.39%
365TCS-INV-0006	1/1/2024	Milestone Draw Request	\$ 38,742.00	\$ (3,874.20)	\$ 34,867.80	0.39%
365TCS-INV-0007	2/1/2024	Milestone Draw Request	\$ 38,742.00	\$ (3,874.20)	\$ 34,867.80	0.39%
365TCS-INV-0008	3/1/2024	Milestone Draw Request	\$ 84,285.22	\$ (8,428.52)	\$ 75,856.70	0.85%
365TCS-INV-0009	4/1/2024	Milestone Draw Request	\$ 209,935.38	\$ (20,993.54)	\$ 188,941.84	2.13%
365TCS-INV-0010	5/1/2024	Milestone Draw Request	\$ 53,593.10	\$ (5,359.31)	\$ 48,233.79	0.54%
365TCS-INV-0011	5/31/2024	Milestone Draw Request	\$ 53,593.10	\$ (5,359.31)	\$ 48,233.79	0.54%
365TCS-INV-0012	7/11/2024	Milestone Draw Request	\$ 38,742.00	\$ (3,874.20)	\$ 34,867.80	0.39%
365TCS-INV-0013	7/18/2024	Milestone Draw Request	\$ 70,424.50	\$ (7,042.45)	\$ 63,382.05	0.71%
365TCS-INV-0014	8/20/2024	Milestone Draw Request	\$ 38,742.00	\$ (3,874.20)	\$ 34,867.80	0.39%
365TCS-INV-0015	9/20/2024	Milestone Draw Request	\$ 38,742.00	\$ (3,874.20)	\$ 34,867.80	0.39%
365TCS-INV-0016	10/22/2024	Milestone Draw Request	\$ 53,593.10	\$ (5,359.31)	\$ 48,233.79	0.54%
365TCS-INV-0017	11/18/2024	Milestone Draw Request	\$ 66,464.36	\$ (6,646.44)	\$ 59,817.92	0.67%
365TCS-INV-0018N	1/1/2025	Milestone Draw Request	\$ 38,742.00	\$ (3,874.20)	\$ 34,867.80	0.39%
365TCS-INV-0019	1/20/2025	Milestone Draw Request	\$ 38,742.00	\$ (3,874.20)	\$ 34,867.80	0.39%
365TCS-INV-0020	3/1/2025	Milestone Draw Request	\$ 58,543.62	\$ (5,854.36)	\$ 52,689.26	0.59%
365TCS-INV-0021	4/1/2025	Milestone Draw Request	\$ 121,908.16	\$ (12,190.82)	\$ 109,717.34	1.24%
365TCS-INV-0022	5/1/2025	Milestone Draw Request	\$ 484,299.12	\$ (15,891.91)	\$ 468,407.21	5.28%
365TCS-INV-0023	6/1/2025	Milestone Draw Request	\$ 1,031,888.71	\$ (98,175.96)	\$ 933,712.75	10.52%
365TCS-INV-0024	6/18/2025	Milestone Draw Request	\$ 38,742.00	\$ (3,874.20)	\$ 34,867.80	0.39%
365TCS-INV-0025	8/1/2025	Milestone Draw Request	\$ 38,742.00	\$ (3,874.20)	\$ 34,867.80	0.39%
365TCS-INV-0026	9/1/2025	Milestone Draw Request	\$ 97,167.10	\$ (3,874.20)	\$ 93,292.90	1.05%
365TCS-INV-0027	10/16/2025	Milestone Draw Request	\$ 166,346.84	\$ (16,634.68)	\$ 149,712.16	1.69%
365TCS-INV-0028	11/3/2025	Milestone Draw Request	\$ 38,742.00	\$ (3,874.20)	\$ 34,867.80	0.39%
365TCS-INV-0029	12/4/2025	Milestone Draw Request	\$ 400,187.37	\$ (24,046.74)	\$ 376,140.63	4.24%
365TCS-INV-0030	1/13/2026	Milestone Draw Request	\$ 38,742.00	\$ (3,874.20)	\$ 34,867.80	0.39%
365TCS-INV-0031	2/6/2026	Milestone Draw Request	\$ 402,207.19	\$ (40,220.72)	\$ 361,986.47	4.08%
365TCS-INV-0032	3/13/2026	Milestone Draw Request	\$ 88,859.98	\$ (8,886.00)	\$ 79,973.98	0.90%
Totals			\$ 5,221,505.83	\$ (462,785.17)	\$ 4,758,720.66	53.62%

SICE INC. - MAINT. PHASE

Contract Amount **\$5,751,746.00**

Date	365 Toll Collection System Maintenance	Billing Amount	Retainage	Invoice Amount	Percentage %
Totals					
		\$ -	\$ -	\$ -	0.00%

Construction Phase			
Schedule A	Implementation Services	\$	2,134,296.54
Schedule B	Hardware	\$	1,986,832.21
Schedule C	Software	\$	203,430.08
Schedule E	Performance Bond & Payment Bond	\$	142,000.00
Change Order CO	Change Order Progress	\$	161,292.80
		\$	4,627,851.63

SCH	Name		
MOH	Material on Hand	\$	593,654.20
		\$	593,654.20

Maintenance Phase			
Schedule D	Maintenance	\$	-
		\$	-

Amount Paid	
Construction	\$ 4,627,851.63
Material On Hand	\$ 593,654.20
Maintenance	\$ -
Less Retainage	\$ (462,785.17)
Total Amount Paid	\$ 4,758,720.66

Construction Phase	
Amount Billed	\$ 5,221,505.83
Retainage	\$ (462,785.17)
Amount Paid	\$ 4,758,720.66
Total Construction Phase Amount:	\$8,874,094.17
Remaining Bal for Const. Phase	\$4,115,373.51

Maintenance Phase	
Total Maintenance Phase Amount:	\$5,751,746.00
Amount Paid	\$0.00
Total Maintenance Phase Amount:	\$5,751,746.00
Remaining Bal for Maint. Phase	\$5,751,746.00

Total Remaining Balance for Const./Maint. including Retainage \$9,867,119.51

Project Schedule and Milestones

Original

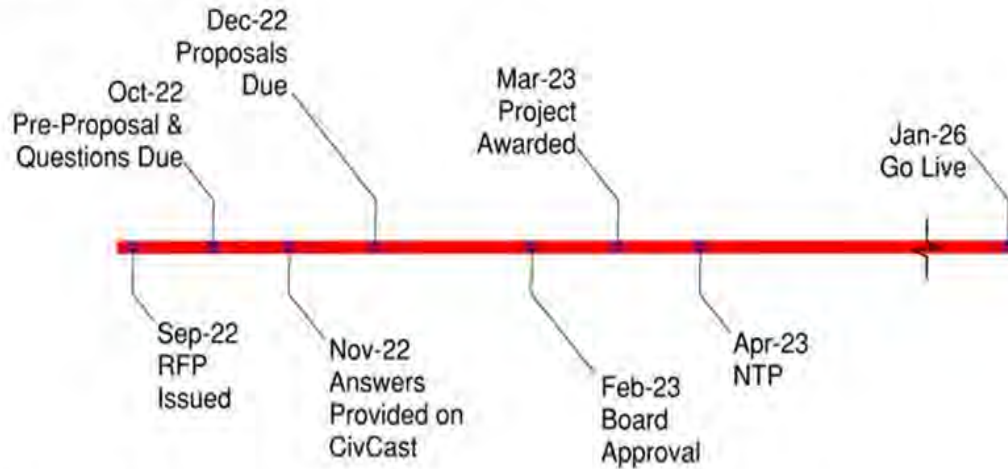

Current

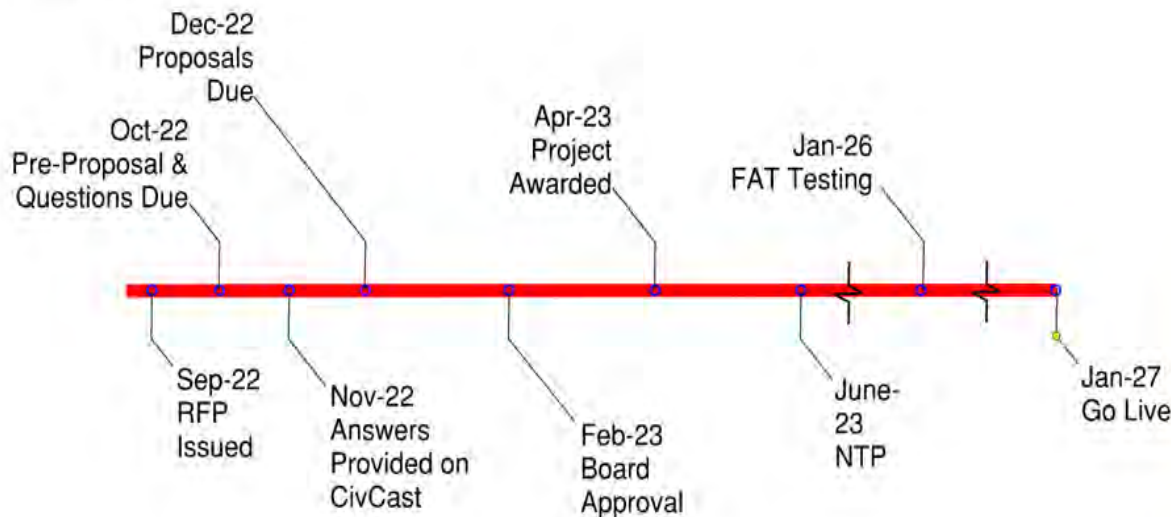

Milestone	Date
NTP	July 6, 2023
Final Design Document	February 2024
Final System Design Document (Roadside)	May 2024
Business Rules Development	November 2024
Final Installation Plans	March 2025
MTG 1 Constructed	August 2025
MTG 1 Fact. Acc. Test	January 2026
Toll Site Commissioning	September 2026
Go Live and SAT	October 2026
Final System Acceptance	April 2027

Executive Summary

365 Tollway – Toll System Integration

Last Month (March 2026):

- Factory Acceptance Test Report received and accepted
- Additional toll equipment installation continues

Next Month (April 2026):

- Additional toll equipment installation
- CBOS configuration for interfacing with Fuego

Challenges

- Civil construction delays shifted go-live.
- Continuing to evaluate civil contractor schedule for fiber optic network and power availability for future gantry testing.

Successes

- Single gantry implementation reduced capital and operations expenses – (Approved by board 11/28/23)
- Addition of height to vehicle classification expected to increase revenue (Approved by board 11/28/23)
- All design documentation received on-time and accepted by HCRMA on-schedule (October 2025)



INDEX DATA SHEET ON PAGE 2

HIDALGO COUNTY REGIONAL MOBILITY AUTHORITY

PLANS OF PROPOSED ROADWAY IMPROVEMENT

FEDERAL AID PROJECT NO. DMO 2013 (420)
365 TOLL



CONTRACT NO.	JOB NO.	SHEET NO.
0921 02	368	365 TOLL
CITY	COUNTY	SHEET NO.
PHR	HIDALGO	

LOCAL ENTITIES	
HIDALGO COUNTY CONCURRENCE #	DATE
HIDALGO COUNTY DRAINAGE DISTRICT NO. CONCURRENCE #	DATE
CITY OF MISSION CONCURRENCE #	DATE
CITY OF GRANJENO CONCURRENCE #	DATE
CITY OF McALLEN CONCURRENCE #	DATE
CITY OF PHARR CONCURRENCE #	DATE
CITY OF SAN JUAN CONCURRENCE #	DATE
I. B. R. C. CONCURRENCE #	DATE
HCD NO. 2 IRRIGATION DISTRICT CONCURRENCE #	DATE
HCD NO. 19 IRRIGATION DISTRICT CONCURRENCE #	DATE
H. C. R. C. 6 I. D. NO. 3 CONCURRENCE #	DATE

LEVEE RELOCATION:
12,232.62 FT + 2.32 MI.

PROJECT LENGTH:
ROADWAY: 58,504.54 FT + 11.08 MI.
BRIDGE: 6,042.00 FT + 1.14 MI.
TOTAL: 64,546.54 FT + 12.22 MI.

LIMITS:
FROM: FM 396 (ANZALDUAS HWY) & GSA CONNECTOR
TO: US 281 (MILITARY HIGHWAY)

CONSTRUCTION OF

A NEW ROADWAY CONSISTING OF GRADING, FLEXIBLE BASE, LIME TREATED SUBGRADE, ASPHALTIC CONCRETE PAVEMENT, CRCP, RETAINING WALLS, CULVERTS, IRRIGATION STRUCTURES, BRIDGE STRUCTURES, TRAFFIC SIGNALS, ILLUMINATION, SIGNING, PAVEMENT MARKINGS, TOLL GANTRIES, TOLL EQUIPMENT, FIBER OPTIC NETWORK, CCTV CAMERAS, VEHICLE DETECTION SYSTEM, BLUETOOTH, DYNAMIC MESSAGE SIGNS, WIRELESS ANTENNAS, ITS POLES, ITS CABINETS, GROUND BOXES, CONDUITS, AND LEVEE RELOCATION



FINAL PLAN DATA :

FINAL CONTRACT PRICE: _____
CONTRACTORS NAME: _____
CONTRACTORS ADDRESS: _____
LETTING DATE: _____
DATE WORK BEGAN: _____
DATE WORK COMPLETED: _____
DATE OF ACCEPTANCE: _____

CHANGE ORDERS & SUPP. AGREEMENTS : _____

SCALE: 1"=2 MI.

ALL CONSTRUCTION WORK WAS PERFORMED IN ACCORDANCE WITH THE PLANS, SPECIFICATIONS AND CONTRACT. ALL PROPOSED CONSTRUCTION WAS COMPLETED UNLESS OTHERWISE NOTED.

ROADWAY OF INCIDENTAL CONSTRUCTION	BEGIN INCIDENTAL CONSTRUCTION	END INCIDENTAL CONSTRUCTION
1 365 TOLL EB FRIG RD	STA 20639+85.55	STA 20650+06.81
2 GSA CONNECTOR	STA 105+59	STA 120+62
3 FM 494 (SHARY RD)	STA 139+25	STA 153+43
4 SP 115 (23rd ST)	STA 226+30	STA 236+22.93
5 MCCOLL ROAD	STA 29+50	STA 51+50
6 FM 2061 (JACKSON RD)	STA 12+00	STA 22+72
7 US 281 (CAGE RD)	STA 12+00	STA 21+32
8 FM 3072 (DICKER RD)	STA 12+60	STA 29+86
9 ANAYA ROAD	STA 17+80	STA 27+40
10 HI-LINE ROAD	STA 27+40	STA 17+80
11 US 281 (MILITARY RD)	STA 10100+00	STA 10227+00
12 BSIF CONNECTOR	STA 1302+18	STA 1338+00

DESIGN SPEED:	RAILROAD CROSSINGS:
MAIN LANES - 70 MPH	RAILROAD CROSSINGS: NONE
FRONTAGE ROADS - 50 MPH	EQUATIONS:
RAMPS - 50 MPH	STA 1080+25.77 BK +
GSA CONNECTOR - 45 MPH	STA 1080+00.00 AH
FM 494 (SHARY RD) - 55 MPH	EXCEPTIONS: NONE
WARE ROAD - 30 MPH	FUNCTION CLASS:
SP 115 (23RD ST) - 55 MPH	PRINCIPAL ARTERIAL (FREEWAY)
SH 336 (10TH ST) - 60 MPH	BRIDGE:
MCCOLL ROAD - 50 MPH	TOTAL: 23 BRIDGES
FM 2061 (JACKSON RD) - 55 MPH	(SEE INDEX SHEET FOR DETAILS)
US 281 (CAGE BLVD) - 55 MPH	TDLR INSPECTION SHALL
ANAYA ROAD - 30 MPH	NOT BE REQUIRED
HI-LINE - 45 MPH	

REGISTERED ACCESSIBILITY SPECIALIST (RAS) INSPECTION REQUIRED.

TDLR No. EABPRJ _____

SPECIFICATIONS ADOPTED BY THE TEXAS DEPARTMENT OF TRANSPORTATION ON NOVEMBER 1, 2014 AND SPECIFICATION ITEMS LISTED AND DATED AS FOLLOWS SHALL GOVERN ON THIS PROJECT. REQUIRED CONTRACT PROVISIONS FOR FEDERAL-AID CONSTRUCTION CONTRACTS (FORM FHWA 1273, MARCH 2012).

365 TOLL

DATE: 6/8/2017 11:06:23 AM
FILE: C:\p\project\hcrma\hcrma\hcrma\working\365-0030-1111E.dgn
COUNTY: HIDALGO PROJ. NO: 365
HWY. NO: 365
DATE ACCEPTED:

APPROVED FOR LETTING : <input type="checkbox"/>	APPROVED FOR LETTING : <input checked="" type="checkbox"/> (6-20-17)
HCRMA, CHAIRMAN	HCRMA, EXECUTIVE DIRECTOR <i>[Signature]</i>
APPROVED FOR LETTING : <input type="checkbox"/>	APPROVED FOR LETTING : <input checked="" type="checkbox"/> (6/20/17)
HCRMA, CHIEF CONSTRUCTION ENGINEER	HCRMA, CHIEF DEVELOPMENT ENGINEER <i>[Signature]</i>
APPROVED FOR LETTING : <input type="checkbox"/>	SUBMITTED FOR LETTING : <input checked="" type="checkbox"/> (6/16/17)
TxDOT, DISTRICT ENGINEER	DANNENBAUM ENGINEERING, PROGRAM MANAGER <i>[Signature]</i>
SUBMITTED FOR LETTING : <input checked="" type="checkbox"/> (6/15/17)	SUBMITTED FOR LETTING : <input checked="" type="checkbox"/> (6/15/17)
L&G ENGINEERING, PROJECT MANAGER <i>[Signature]</i>	S&B INFRASTRUCTURE, PROJECT MANAGER <i>[Signature]</i>
TEDSI INFRASTRUCTURE GROUP, PROJECT MANAGER <i>[Signature]</i>	

PROGRAM MANAGEMENT CONSULTANT
DANNENBAUM ENGINEERING CORPORATION
3. B. P. E. FIRM REGISTRATION #0922
1388 NOLANA LOOP, 815 AM WILSON, TX 75150-9822

L&G Engineering
Highway / Civil
Structural / Bridge
Accessories
Plan, Spec & Est

S&B
S&B INFRASTRUCTURE LTD.
1844 ROAD OF PROFESSIONALS, SUITE # 2102

TEDSI
INFRASTRUCTURE GROUP

This sheet was not changed as part of the VECP design process and remains in its original IFC state.



EXECUTIVE SUMMARY

- ❑ The Notice to Proceed (NTP) was issued to Pulice Construction Inc. (PCI) on February 15, 2022, with time charges commencing on March 17, 2022.
- ❑ The work under this contract was to be substantially completed within **1,264 CALENDAR** days [September 23, 2025] After Substantial Completion, Pulice will be allowed up to an additional 60 calendar days for Final Acceptance.
- ❑ Working days will be charged Sunday through Saturday, including all holidays with exception of:

New Year's Day (January 1st)

Independence Day (July 4th)

Labor Day (1st Monday in the month of September)

Thanksgiving Day and day after (4th Thursday and Friday in the month of November);

Christmas Eve and Day (December 24th and 25th)

Regardless of weather conditions, material availability, or other conditions not under the control of the contractor, except as expressly provided for in the contract. If contractor fails to complete the work on or before the contract time, Pulice Construction Inc. agrees to pay the Authority \$ 16,500 per day as liquidated damages to cover losses, expenses and damages of the Authority for every calendar day which the contractor fails to achieve substantial completion of the project.

- ❑ The total construction cost submitted \$ 295,932,420.25.

HCRMA 365 TOLL PROJECT CSJ#0921-02-368: CHANGE ORDER SUMMARY

Twenty-one (21) approved Changes Order(s): [\$6,292,344.35] +0 days

CO#1 11/11/2021 entering VECP process	+000 days	\$000,000,000.00	.09%
CO#2 12/21/2021 VECP Plan Revisions	+000 days	\$(14,208,622.30)	(5.04%)
CO#3 04/26/2022 VECP Contractor Risk	+000 days	\$000,000,000.00	(0%)
CO#4 01/24/2023 Drill Shafts	+000 days	\$171,516.59	0.06%
CO#5 06/24/2023 VECP True Realized Savings	+000 days	<u>\$4,325,130.78</u>	1.51%
CO#6 07/09/2024 Depot Road rmve cul-de-sac	+000 days	(-\$30,843.33)	(0.01%)
CO#7 07/09/2024 Mission waterline conflict	+000 days	\$13,075.83)	0.00%
CO#8 07/09/2024 drill shaft casing conflict	+000 days	\$20,932.00	0.01%
CO#9 07/09/2024 irrigation PVC / LHPP	+000 days	(-\$1,782.00)	(0%)
CO#10 07/09/2024 TCP amendments	+000 days	\$249,919.32	0.09%
CO#11 07/09/2024 add McColl driveway	+000 days	\$23,450.97	0.01%
CO#12 07/09/2024 City of Pharr waterline	+000 days	\$135,487.78	0.05%
CO#13 07/09/2024 Traffic signal/central cabinets	+000 days	\$212,599.20	0.08%
CO#14 01/21/2025 CIP Manholes	+000 days	\$449,436.36	0.16%
CO#15 01/21/2025 Site specific re-mobilization	+000 days	\$150,000.00	0.05%
CO#16 09/23/2025 Riprap (Stone TY R) (DRY) (12IN)	+000 days	\$65,012.89	0.02%
CO#17 01/27/2026 Kill Switches	+000 days	\$99,430.28	0.04%
CO#18 02/24/2026 San Juan Main Canal Sheet Piling	+000 days	\$1,408,666.85	0.50%
CO#19 02/24/2026 C361 LHPP	+000 days	\$524,621.53	0.19%
CO#20 02/24/2026 Irrigation Hardware	+000 days	\$77,699.30	0.03%
CO#21 03/24/2026 Concrete Driveway	+000 days	\$21,923.60	0.03%

CHANGE ORDERS:

Change Order No.1 Summary: November 10, 2021, Resolution 2021-54

- The Primary purpose of Change Order No. 1 is for the HCRMA and contractor to enter a defined VECP proves to reduce the overall cost of the project based on a 30% design furnished by the contractor.
- Cost to the Project include: 30% of 5% of the project savings to the project or direct costs to the contractor, whichever is less. These costs are intended to pay the contractor for design work achieve a 30% design.
- The HCRMA assumes ownership of all design work developed by the contractor, and cost savings are shared by the HCRMA and contractor by 40% and 60% respectively.

Change Order No. 2 Summary: December 20, 2021 Resolution 2021-78

- Change order No. 2 amended the contract price from \$295,932,420.25 to \$281,723,797.95.
- By execution of Change Order No. 1, the contractor completed a 30% design to an effort to estimate cost savings for the project. Payment for the contractor’s initial design work is \$613,285.06 in accordance with calculations presented in Change Order No. 1. This is the only cost due to the contractor based on the execution of Change Order No. 2, and is non-participating.
- Notice to proceed was issued 2/15/2022, the HCRMA reimburse the contractor for the remaining design costs to not exceed 5% of the total cost savings. Payments made will be based upon design milestones at 60%, 90% and 100% completion and acceptance.

VECP calculations for Contract Price of \$281,723,797.95

VECP Gross Savings	\$38,010,382.63	
Less est. Total Design Cost	\$1,943,648.45	(Schematics + Final Design)
Less Est. Owner’s Fees	\$545,178.43	(GEC, Environmental, T&R Costs)
VECP Net Savings	\$35,521,555.76	
60% Contractor Saving:	\$21,312,933.45	Paid as Progress Payments
40% Owner Savings:	\$14,208,622.30	Reduced from original Project

Change Order No. 3 Summary: April 26, 2022 Resolution 2022-36

- As provided for Contract Amendment #1 and Change Order No. 2, the Contractor’s share of the net savings includes the “Contractor Risk” that the actual costs of implementing the approved VECP concepts in Change Order No. 2 may not result in the saving approved by the parties. To the extent total actual costs exceed the total amount approved, all overages due to errors, oversights, omissions, additions, or corrections to final units, final quantities, or final unit prices or costs increases shall be deducted from Contractor 60% portion of the net savings.
- To the extent actual costs exceed the amounts presented in Exhibit A, Contractor agrees that such overages due to errors, oversight, omission additions, or corrections to final units, quantities or unit pricing shall be deducted from contractor’s 60% portion of the net savings (the “Contractor Risk”).
- Contractor VECP Savings Payments.
Contractor’s share of the savings shall be calculated and paid out as progress payments under the terms of the contract, as follows:

<u>Construction Progress</u>	<u>Proposed Savings Payment</u>
20% Completion	\$4,262,586.69
40% Completion	\$4,262,586.69
60% Completion	\$4,262,586.69
80% Completion	\$4,262,586.69
Final Acceptance	<u>\$4,262,586.69</u>
	\$21,312,933.45

The parties agree that if the Savings are not apparent or justified during a designated progress period, all, or part of any such Savings Payment, on the recommendation of the General Engineering Consultant, may be (i) deferred to the next progress period or (iii) reduced to reflect the Contractor's Risk for unrealized Savings/overages.

Change Order No. 4 Summary: January 24, 2023 Resolution 2023-05

Change Order No. 4 removes 1,524LF of Item 416-6005 Drill Shaft (42") introduces 48" drill shafts to incorporate detailed, finalized quantities and unit costs; and establishes State/Federal participation on odified unit costs, assuring compliance with the standard specifications included within the contract. Change Order No. 4 introducing 1,585LF of Item 416-6006 Drill Shaft (48 IN) at a unit cost of \$308.39/LF for a net cost of \$171,516.59 to be fully paid by HCRMA [Owner].

Change Order No. 5 Summary: June 24, 2023 Resolution 2023-30

In Lieu of \$38,010,382.63 savings, they only can truly account for \$30,565,888. They are claiming that of the \$7,444,494.63 shortfall, only \$3,186,525.45 is from their 60%; additional \$4,257,969.18 are contributable to busts in original plans, design errors and quantity mistakes and are to be attributed to HCRMA contingency[\$14,037,105.71].

- As provided for Contract Amendment #1 and Change Order No. 2, the Contractor's share of the net savings includes the "Contractor Risk" that the actual costs of implementing the approved VECP concepts in Change Order No. 2 may not result in the saving approved by the parties. To the extent total actual costs exceed the total amount approved, all overages due to errors, oversights, omissions, additions, or corrections to final units, final quantities, or final unit prices or costs increases shall be deducted from Contractor 60% portion of the net savings. *The unrealized savings presented are \$1,911,468.20*
 - To the extent actual costs exceed the amounts presented in Exhibit A, Contractor agrees that such overages due to errors, oversight, omission additions, or corrections to final units, quantities or unit pricing shall be deducted from contractor's 60% portion of the net savings (the "Contractor Risk"), *revised shall be \$19,401,465.25*



Contractor VECP Savings Payments are amended, as such:

Contractor's share of the savings shall be calculated and paid out as progress payments under the terms of the contract, as follows:

Construction Progress	Proposed Savings	Payment	Paid Date
**20% Completion	\$4,262,586.69		12/22/22
40% Completion	\$4,262,586.69	\$3,728,764.51	01/17/24
60% Completion	\$4,262,586.69	\$3,728,764.51	12/18/24
80% Completion	\$4,262,586.69	\$3,840,674.77	TBD
Final Acceptance	\$4,262,586.69	\$3,840,674.77	TBD
	\$21,312,933.45	\$19,401,465.25	

**[\$19,401,465.25 - \$11,720,115.71 = \$7,681,349.54] REMAINING BALANCE

Change Order No. 6 - 13 Summary: July 9, 2024 Resolution 2024-27

These are a compilation of various Field Changes: Attached exhibits provide current assessment and breakdown.

Change Order No. 6 Summary: (-\$30,843.33)

The scope of this change is to compensate them for changes related to Depot Road (southbound frontage road for SP115) which will remain in place at the directive of TxDOT. The existing SB frontage road (Depot) will be left in place in lieu of obliteration and cul-de-sac. As a result, the proposed levee will be reduced, guard rail and rail Ty T80PP will be added to protect columns. In addition, the TCP is revised to allow for the phased additional work.

Change Order No. 7 Summary: \$13,075.83

This change resolves an unanticipated utility conflict between the city of Mission 16" waterline casing and proposed drainage line at station 649+00. In lieu of the the proposed 5' x 5', an 8'x8' Conflict Manhole must be installed to accommodate construction.

Change Order No. 8 Summary: \$20,932.00

The 60" drill shafts from FM 494 Bent 2 are in conflict with placed 24" water line casing. The existing 24" RCP CL V water line casing would need to be removed and relayed using the same pipe. Estimated damaged pipe would need to be new RCP.

Change Order No. 9 Summary: (-\$1,782.00)

Due to existing field conditions, the irrigation line from station 752+36.15 to 760+66.11 increased from 18" Pressure Irrigation PVC pipe to 36" LHPP. CO#5 instrumented replacement to 36" LHPP. However, due to immediate material need and unavailability, a 30" LHPP was placed in lieu of 36"

Change Order No. 10 Summary: \$249,919.32

Pertinent plan sheets depicted traffic control plan implementing portable concrete traffic barriers and crash cushion appurtenances for safety of traveling public; however, items were not included in estimate.

Change Order No. 11 Summary: \$23, 450.97

This change adjusts items per driveway revisions on McColl Rd. The proposed NW driveways were revised to provide better access for the local businesses and to add end treatment components for safety purposes at driveway intersections.

Change Order No. 12 Summary: \$135,487.78

The scope of this change is to add and adjust items related to the 18" waterline relocation. Items were accounted in plans but not placed on estimate.

Change Order No. 13 Summary: \$212,599.20

TS pole mounted cabinets (TY 2 CONF 2) to be installed, attached to the vertical mast of existing and proposed traffic signal poles. Installing ITS cabinets on traffic signal poles is not per TxDOT standard. Cabinets are to be installed as ground mounted to specifications.

Change Order No. 14 Summary, January 24, 2025, Resolution 2025-07 : \$449,436.36

Third party governmental agency is requiring cast-in-place manholes within jurisdictional boundaries.

Change Order No. 15 Summary, January 24, 2025 Resolution 2025-08 : \$150,000.00

Due to ongoing requests from third party governmental agency, unanticipated parameters and numerous conditional changes in requirements, untimely review of requested changes, and unavailability of service lines various subcontractors of Pulice Construction Inc. have encountered scheduling delays. These delays incur expenses in scheduling crews and mobilizing specialized equipment. The presented conditions are beyond their control.

Change Order No. 16 Summary, August 26, 2025 Resolution 2025-55 : \$65,012.89

On 12/20/2024 HCRMA received request (third party) to extend scour protection along the canal base and interior side slopes of proposed Jackson by-pass. RipRap (Stone TY R) (DRY) (12IN) was not included in the original Contract. C.O. amends riprap type from "common" to TY R (dry) total of 196 CY [\$331.70 per CY] for total cost of \$65,012.89.

Change Order No. 17 Summary, January 27, 2026 Resolution 2026-18 : \$99,430.28

Change Order Number Sixteen (17) adds a new line item to contract to compensate Contractor for the addition of thirty-two (32) unfused switch boxes, all added components, and labor required for installation and compliance. Additional time request was mentioned but never formally submitted. The sum of Change Order#17 proves a maximum cost increase of \$99,430.28.

The sum of Change Orders proves a net cost increase of \$1,386,719.30 to be fully paid by HCRMA [Owner]. Establishing a new revised contract price of \$286,843,285.09 with no additional time; and, incorporates detailed, finalized quantities and unit costs; and establishes State/Federal participation on modified unit costs, assuring compliance with the standard specifications included within the contract.

Change Order No. 18 Summary, February 24, 2026 Resolution 2026-26 : \$1,408,666.85

HCID #2 agreed to proceed with Option 2 of the San Juan Main Canal, which no longer required a bypass but instead uses sheet piling to install the necessary substructures required for the construction of the Pharr/San Juan Canal Bridge. This change order introduces the sheet piling installation and removal items needed to complete this work. Contractor agrees to coordinate directly with utility to complete the work in a timely manner

Change Order No. 19 Summary, February 24, 2026 Resolution 2026-27 : \$524,621.53

Implementing ASTM C361 materials and requirements for Item 476 tunneling operation and placement of reinforced concrete low head pressure pipe and increasing number of concrete well connections. The sum of Change Order#19 proves a maximum cost increase of \$524,621.53. Contractor agrees to coordinate directly with utility to complete the work in a timely manner.

Change Order No. 20 Summary, February 24, 2026 Resolution 2026-28 : \$77,699.30

The original slide gates that were acquired did not meet Buy America requirements and could not be incorporated into the project. Hidalgo County Irrigation District #2 [HCID2] required stainless steel components, which did not comply with Buy America requirements, to be incorporated onto their irrigation structures. This change order will compensate Pulice Construction Inc. [PCI] for acquiring new slide gates containing stainless steel components and installing appurtenances into HCID2's irrigation structures as required in the project plans and as agreed to with HCID2. Additional time request was mentioned but never formally submitted.

Change Order No. 21 Summary, March 24, 2026 Resolution 2026-31 : \$21,923.60

CO introduces a line item to the contract to compensate Contractor for the addition of concrete driveways. This particular change includes driveway to the the City of Mission's infrastructure along the Anzalduas Connector.

PROJECT PRODUCTION

□ CAPTURING VECP PACKETS

- 02/08/23 VECP Team met, exchanged concepts, formats
- 03/08/23 VECP meeting formal report submitted
- 04/20/23 VECP concepts completed and negotiations underway
- 07/07/23 New revised baseline schedule
- 07/10/23 CO#5 terms and conditions
- 02/23/24 CO#6 conditions and negotiations
- 07/09/24 CO#6 - 13 various
- 01/24/25 CO#14 rev CIP manholes
- 01/24/25 CO#15 site specific remobilization fees

□ FORMAL SUBMITTALS, REVIEW OF DOCUMENTS

- RFIs 275
- SUBMITTALS 253

□ TESTING [Soils/Concrete]

- Levees / embankment / select fill
- Drill shafts / bents / slab
- Roadway. limed subgrade / cement treated base / CRCP / SSCB
- MSE Backfill
- Irrigation Structures
- FORENSICS [MSE panels / Bridge substructures]

□ ENVIRONMENTAL JUSTICES [SW3Ps] Archeological Sites

□ EMBANKMENT: Shary / SH336 / SP115 / Jackson/ Dicker/ Highline / McColl / Anaya / Cage

□ UNDERGROUND WORK: Storm Sewer / Irrigation structures / Tolling Conduit

□ LEVEE Work: Ware / Jackson / US281

□ Bridge Substructure FM494 / Floodway / SP115 / SH336/ McColl / Ditch Bridge / Highline / Anaya

- BEAMS SET: McColl / Canal Bridge / Floodway- SP115 / FM494/ SH336 / Anaya / Dicker

□ RETAINING WALLS Highline / Anaya / SP115 / SH336 / Jackson / US281



RETAINING WALL#14 EAST SIDE OF JACKSON



31 Mar 2026, 17:14:25





APRIL 9, 2026 JACKSON BYPASS

General Information

Project

Work Type
Heavy Highway

Location



Texas Parks & Wildlife, CONANP, Esri, Tom... Powered by Esri
Coordinates
26.14052384945899, -98.24062242016183

Location
FM-396 (ANZALDUAS HIGHWAY) TO US-281 MILITARY HIGHWAY

Esri Integration
On

Management

Prime Contractor
PULICE CONSTRUCTION, INC.

Project Manager
Ramon Navarro, IV., P.E.

Managing Office
HCRMA Construction Department

Created By
Sergio Mandujano

Awarded Amount
\$295,932,420.25

Authorized Amount
\$266,734,461.86

Approved Changes
-\$29,197,958.39

Description

GREENFIELD PROJECT, PRINCIPAL ARTERIAL, CONTROLLED ACCESS HIGHWAY, TOLL IMPROVEMENT, CSJ: 0921-02-368 ALN#:20.205

Amount Paid

Amount paid so far
\$195,867,808.99

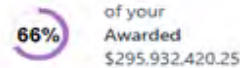

Important Dates

Date Created
Apr 22, 2022

Notice to Proceed
Feb 15, 2022

Construction Start
Mar 17, 2022

Work Completion
Sep 23, 2025

Progress

Time Complete: 1471 Days

Time Remaining: -207 Days



Amount Posted: \$177,028,421.44

Awarded Amount: \$295,932,420.25



Amount Posted: \$177,028,421.44

Authorized Amount: \$266,734,461.86



Total Retainage
\$0.00

Retainage Released
\$0.00

Liquidated Damages
\$9,454,500.00

Summary

Current Approved Work:	\$1,615,697.58	Approved Work To Date:	\$176,299,939.29
Current Stockpile Advancement:	\$790,213.12	Stockpile Advancement To Date:	\$55,778,237.10
Current Stockpile Recovery:	\$509,282.63	Stockpile Recovery To Date:	\$31,789,239.33
Current Retainage:	\$0.00	Retainage To Date:	\$0.00
Current Retainage Released:	\$0.00	Retainage Released To Date:	\$0.00
Current Liquidated Damages:	\$511,500.00	Liquidated Damages To Date:	\$3,036,000.00
Current Adjustment:	\$0.00	Adjustments To Date:	\$0.00
Current Payment:	\$1,385,128.07	Payments To Date:	\$197,252,937.06

Business: HCRMA
Project Name: 365 TOLL PROJECT CSJ:0921-02-368 ALN#20.205
Project Description: GREENFIELD PROJECT, PRINCIPAL ARTERIAL, CONTROLLED ACCESS HIGHWAY, TOLL IMPROVEMENT,
Prime Contractor: PULICE CONSTRUCTION, INC.
Notice to Proceed Date: 2/15/2022
Construction Start Date: 3/17/2022
Awarded Project Amount: \$ 295,932,420.25
Net Change by Change Orders: \$ (29,197,958.39)
Authorized Project Amount: \$ 266,734,461.86
% Complete Paid Awarded Amount: 64.978
% Complete Paid Authorized Amount: 72.09
LDs CURRENTLY APPLIED: \$3,052,500.00
Payment History:

Payment Number	Pay Period Start	Pay Period End	Payment Amount	Payment To Date	Monthly Production	Cumulative Production	Payment Status
48	3/1/2026	3/31/2026	\$1,385,126.07	\$ 197,252,937.00	0.52	73.95	PENDING
48	2/1/2026	2/28/2026	\$1,928,963.06	\$ 195,867,808.99	0.72	73.43	Paid
47	1/1/2026	1/31/2026	\$ 1,551,875.45	\$ 193,940,845.93	0.58	72.71	Paid
46	12/24/2025	12/31/2025		\$ 192,388,970.48	0.00	72.13	Paid
45	12/1/2025	12/23/2025	\$ 763,266.30	\$ 192,388,970.48	0.29	72.13	Paid
44	11/1/2025	11/30/2025	\$ 913,944.12	\$ 191,605,765.18	0.34	71.83	Paid
43	10/1/2025	10/31/2025	\$ 1,061,473.96	\$ 190,692,221.06	0.73	71.49	Paid
42	9/1/2025	9/30/2025	\$ 1,844,308.10	\$ 188,750,747.10	0.69	70.76	Paid
41	8/1/2025	8/31/2025	\$ 2,336,996.78	\$ 186,906,439.00	0.88	70.07	Paid
40	7/1/2025	7/31/2025	\$ 2,890,565.47	\$ 184,567,440.22	1.07	69.20	Paid
39	6/1/2025	6/30/2025	\$ 3,118,773.89	\$ 181,706,674.75	1.17	68.12	Paid
38	5/1/2025	5/31/2025	\$ 3,864,124.73	\$ 178,588,101.06	1.49	66.80	Paid
37	4/1/2025	4/30/2025	\$ 1,945,776.17	\$ 174,723,976.33	0.73	65.50	Paid
36	3/1/2025	3/31/2025	\$ 5,405,968.53	\$ 172,778,200.16	2.03	64.78	Paid
35	2/1/2025	2/28/2025	\$ 6,280,109.35	\$ 167,372,231.63	2.30	62.75	Paid
34	12/29/2024	1/31/2025	\$ 5,697,310.43	\$ 161,074,322.28	2.14	60.39	Paid
33	12/1/2024	12/26/2024	\$ 5,656,543.44	\$ 155,376,811.05	2.12	58.25	Paid
32	10/16/2024	11/30/2024	\$ 8,822,222.41	\$ 149,720,268.39	3.31	56.15	Paid
31	9/16/2024	10/15/2024	\$ 3,166,880.19	\$ 146,896,045.09	1.19	52.62	Paid
30	8/16/2024	8/15/2024	\$ 3,999,288.82	\$ 137,728,195.80	1.50	51.63	Paid
29	7/16/2024	8/15/2024	\$ 5,706,638.29	\$ 133,728,905.88	2.17	50.14	Paid
28	6/16/2024	7/15/2024	\$ 2,006,402.62	\$ 127,942,267.69	0.76	47.97	Paid
27	5/16/2024	6/15/2024	\$ 3,637,006.93	\$ 125,935,864.67	1.36	47.21	Paid
26	4/16/2024	5/15/2024	\$ 3,371,381.76	\$ 122,298,857.94	0.85	45.85	Paid
25	3/16/2024	4/15/2024	\$ 5,795,908.13	\$ 120,927,506.10	2.17	45.00	Paid
24	2/16/2024	3/15/2024	\$ 2,969,684.68	\$ 114,228,597.05	1.11	42.82	Paid
23	1/16/2024	2/15/2024	\$ 4,392,674.67	\$ 111,259,712.47	1.63	41.71	Paid
22	12/16/2023	1/15/2024	\$ 3,794,704.56	\$ 106,906,037.80	1.42	40.08	Paid
21	11/16/2023	12/15/2023	\$ 3,678,608.67	\$ 103,107,333.22	2.88	38.08	Paid
20	10/16/2023	11/15/2023	\$ 6,172,155.40	\$ 95,428,524.25	2.31	35.78	Paid
19	9/16/2023	10/15/2023	\$ 5,115,897.33	\$ 89,266,368.79	1.92	33.48	Paid
18	8/16/2023	9/15/2023	\$ 7,197,089.08	\$ 84,140,671.46	2.60	31.54	Paid
17	7/16/2023	8/15/2023	\$ 6,632,158.94	\$ 76,983,682.38	2.97	29.86	Paid
16	6/16/2023	7/15/2023	\$ 2,803,228.26	\$ 71,451,423.44	1.05	26.79	Paid
15	5/16/2023	6/15/2023	\$ 3,402,150.75	\$ 68,648,198.18	0.90	25.74	Paid
14	4/16/2023	5/15/2023	\$ 1,672,612.23	\$ 66,246,047.43	0.63	24.84	Paid
13	3/16/2023	4/15/2023	\$ 2,302,599.87	\$ 64,573,235.20	0.86	24.21	Paid
12	2/16/2023	3/15/2023	\$ 1,571,621.63	\$ 62,270,729.33	0.50	23.35	Paid
11	1/16/2023	2/15/2023	\$ 1,819,297.77	\$ 60,699,107.70	0.67	22.76	Paid
10	12/16/2022	1/15/2023	\$ 943,705.68	\$ 58,179,809.99	0.35	22.19	Paid
9	11/16/2022	12/15/2022	\$ 8,892,613.78	\$ 58,236,104.28	3.33	21.83	Paid
8	10/15/2022	11/14/2022	\$ 4,065,662.35	\$ 48,343,490.50	3.53	18.50	Paid
7	9/16/2022	10/14/2022	\$ 1,427,873.36	\$ 45,257,888.16	0.54	16.97	Paid
6	8/19/2022	9/15/2022	\$ 657,136.92	\$ 43,830,014.79	0.25	16.43	Paid
5	7/29/2022	8/18/2022	\$ 378,458.17	\$ 43,172,677.87	0.14	16.18	Paid
4	6/21/2022	7/19/2022	\$ 2,793,575.17	\$ 42,794,319.70	1.95	16.04	Paid
3	6/1/2022	6/20/2022	\$ 2,336,832.39	\$ 40,000,644.52	0.88	15.00	Paid
2	5/1/2022	5/31/2022	\$ 14,029,200.82	\$ 37,664,012.14	5.26	14.12	Paid
1	2/15/2022	4/30/2022	\$ 23,634,811.32	\$ 23,634,811.32	6.86	5.86	Paid

Total:

\$197,252,937.00

MOH to 3/31/26		
TOTAL	RECOVERED	PENDING
\$56,778,237.18	\$32,142,039.55	\$23,636,197.55





This Page
Intentionally
Left Blank

Item 3A

HIDALGO COUNTY REGIONAL MOBILITY AUTHORITY

AGENDA RECOMMENDATION FORM

BOARD OF DIRECTORS	<u> X </u>	AGENDA ITEM	<u> 3A </u>
PLANNING COMMITTEE	<u> </u>	DATE SUBMITTED	<u> 4/17/2026 </u>
FINANCE COMMITTEE	<u> </u>	MEETING DATE	<u> 4/28/2026 </u>
TECHNICAL COMMITTEE	<u> </u>		

1. Agenda Item: **APPROVAL OF MINUTES FOR THE BOARD OF DIRECTOR'S REGULAR MEETING HELD MARCH 24, 2026.**

2. Nature of Request: (Brief Overview) Attachments: X Yes No
Approval of Minutes for the HCRMA Board of Directors Regular Meeting held March 24, 2026.

3. Policy Implication: Board Policy, Local Government Code, Texas Government Code, Texas Transportation Code, TxDOT Policy

4. Budgeted: Yes No X N/A

5. Staff Recommendation: **Motion to approve the minutes for the Board of Director's Regular Meeting held on March 24, 2026.**

6. Program Manager's Recommendation: Approved Disapproved X None

7. Planning Committee's Recommendation: Approved Disapproved X None

8. Board Attorney's Recommendation: Approved Disapproved X None

9. Chief Auditor's Recommendation: Approved Disapproved X None

10. Chief Financial Officer's Recommendation: Approved Disapproved X None

10. Chief Development Engineer's Recommendation: Approved Disapproved X None

11. Chief Construction Engineer's Recommendation: Approved Disapproved X None

12. Executive Director's Recommendation: X Approved Disapproved None

**STATE OF TEXAS
COUNTY OF HIDALGO
HIDALGO COUNTY REGIONAL MOBILITY AUTHORITY**

The Hidalgo County Regional Mobility Authority Board of Directors convened for a Workshop and Regular Board Meeting on Tuesday, March 24, 2026, at 4:30 pm at the Pharr City Hall, 2nd Floor City Commission Chambers, 118 S. Cage, Blvd., Pharr, TX 78577, with the following participating:

Board Members: Robert L. Lozano, Chairman (Teleconference)
Juan Carlos Del Ángel, Vice-Chairman
Michael Williamson, Secretary/Treasurer
Jose Maria “Joe” Ochoa, Director
Joe Daniel Olivarez, Director
Javier Peña, Director

Absent: Nick Rhodes, Director

Staff: Pilar Rodriguez, Executive Director
Ramon Navarro, Chief Construction Engineer
Rudy Palomares, Construction Engineer
Maria Alaniz, Program Coordinator
Richard Cantu, Law Office of Richard Cantu, Legal Counsel
Richard Ramirez, Hilltop Securities, Financial Advisor

Vice Chairman Juan Carlos Del Ángel was the presiding officer for the meeting.

PLEDGE OF ALLEGIANCE

Vice Chairman Del Ángel led the Pledge of Allegiance.

INVOCATION

Mrs. Maria Alaniz led the invocation.

CALL TO ORDER OF A WORKSHOP at 4:30 P.M.

1. Presentation of toll exemptions and/or discounts for emergency vehicles and disabled veterans.
Mr. Andrew Cadmus of HDR Engineering, Inc. presented toll exemptions and/or discounts for emergency vehicles and disabled veterans.

ADJOURNMENT OF WORKSHOP AT 4:41 P.M.

CALL TO ORDER AND ESTABLISHMENT OF A QUORUM FOR A REGULAR MEETING

Vice Chairman Del Ángel called the Regular Meeting to order at 4:31 p.m.

PUBLIC COMMENT

No Comments

1. CHAIRMAN'S REPORT

- A. Western Hidalgo County Loop System Development
- B. Status Reports from Administration, Project, and Revenue Committees

2. REPORTS

- A. Report on Program Management Activity for 365 Tollway Project – HCRMA Staff
Mr. Pilar Rodriguez reported on Program Manager Activity for 365 Tollway Project. No action taken.
- B. Report on Construction Activity for the 365 Tollway Project – Ramon Navarro IV, HCRMA.
Mr. Ramon Navarro reported on the construction activity for the 365 Tollway Project. No action taken.

3. CONSENT AGENDA

Motion by Joe Ochoa, with a second by Javier Peña, to approve the Consent Agenda. Motion carried unanimously.

- A. Approval of Minutes for the Regular Board Meeting held February 24, 2026 and the Special Board Meeting held March 24, 2026.
Approved the Minutes for the Regular Board Meeting held February 24, 2026 and the Special Board Meeting held March 24, 2026.
- B. Approval of Project & General Expense Report for the period from February 7, 2026 to March 6, 2026.
Approved the Project & General Expense Report for the period from February 7, 2026 to March 6, 2026.
- C. Approval of Financial Reports for January 2026.
Approved the Financial Reports for January 2026.
- D. Resolution 2026 Resolution 2026-33 - Consideration and approval Supplemental Number 2 to Work Authorization number 2 to the professional services agreement with Terracon Consultants, Inc. for a no-cost time extension to provide CMT services for the 365 Tollway project.
Approved Resolution 2026 Resolution 2026-33 - Consideration and approval Supplemental Number 2 to Work Authorization number 2 to the professional services agreement with Terracon Consultants, Inc. for a no-cost time extension to provide CMT services for the 365 Tollway project.

- E. Resolution 2026-34 - Consideration and approval Supplemental Number 1 to Work Authorization number 3 to the professional services agreement with Terracon Consultants, Inc. for a no-cost time extension to provide CMT services for the 365 Tollway project.
Approved Resolution 2026-34 - Consideration and approval Supplemental Number 1 to Work Authorization number 3 to the professional services agreement with Terracon Consultants, Inc. for a no-cost time extension to provide CMT services for the 365 Tollway project.
- F. Resolution 2026-35 - Consideration and approval Contract Amendment Number 3 to the professional services agreement with Terracon Consultants, Inc. for a no-cost time extension to provide CMT services for the 365 Tollway project.
Approved Resolution 2026-35 - Consideration and approval Contract Amendment Number 3 to the professional services agreement with Terracon Consultants, Inc. for a no-cost time extension to provide CMT services for the 365 Tollway project.
- G. Resolution 2026-36 - Consideration and approval Contract Amendment number 1 to the Professional Service agreement with Atser L.P., for a no-cost time extension to provide Construction Materials Testing lab services and forensic investigation as part of the 365 Tollway project.
Approved Resolution 2026-36 - Consideration and approval Contract Amendment number 1 to the Professional Service agreement with Atser L.P., for a no-cost time extension to provide Construction Materials Testing lab services and forensic investigation as part of the 365 Tollway project.

4. REGULAR AGENDA

- A. Resolution 2026-31 - Consideration and approval of Change Order Number 21 to that certain contract with Pulice Construction, Inc. for the 365 Tollway construction project.
Motion by Joe Olivarez, with a second by Michael Williamson, to approve Resolution 2026-31 - Consideration and approval of Change Order Number 21 to that certain contract with Pulice Construction, Inc. for the 365 Tollway construction project in the amount of 21,923.60. Motion carried unanimously.
- B. Resolution 2026-37 - Consideration and approval of agreement with AEP Texas, Inc. to Install Electric Distribution Facilities for New Electrical Services for the 365 Tollway Project.
Motion by Michael Williamson, with a second by Carlos Del Angel, to approve Resolution 2026-37 - Consideration and approval of agreement with AEP Texas, Inc. to Install Electric Distribution Facilities for New Electrical Services for the 365 Tollway Project in the amount of \$33,883.90. Motion carried unanimously.
- C. Resolution 2026-38 - Consideration and approval of Supplemental Number 9 to Work Authorization Number 8 to the Professional Service agreement with HDR Engineering, Inc. to provide construction record keeping services as part of the 365 Tollway Project.
Motion by Michael Williamosn, with a second by Joe Ochoa, to approve Resolution 2026-38 - Consideration and approval of Supplemental Number 9 to Work Authorization Number 8 to the Professional Service agreement with HDR Engineering, Inc. to provide construction record keeping services as part of the 365 Tollway Project in the amount to of \$90,481.00. Motion carried unanimously.

- D. Resolution 2026-39 - Consideration and approval of Contract Amendment Number 18 to the Professional Service agreement with HDR Engineering, Inc. to increase the maximum amount payable for Supplemental Number 9 to Work Authorization Number 8 for the 365 Tollway Project.

Motion by Michael Williamosn, with a second by Joe Olivarez, to approve Resolution 2026-39 - Consideration and approval of Contract Amendment Number 18 to the Professional Service agreement with HDR Engineering, Inc. to increase the maximum amount payable for Supplemental Number 9 to Work Authorization Number 8 for the 365 Tollway Project in the amount of \$90,481.00, revising the maximum payable amount to \$8,053,051.08 . Motion carried unanimously.

- E. Discussion and possible action on the selection of a candidate and approval of employment terms for the executive director position.

Motion by Javier Pena, with a second by Joe Ochoa, to approve selection of a candidate and approval of employment terms for the executive director position. Motion carried unanimously.

5. TABLED ITEMS

- A. None.

6. EXECUTIVE SESSION, CHAPTER 551, TEXAS GOVERNMENT CODE, SECTION 551.071 (CONSULTATION WITH ATTORNEY), SECTION 551.072 (DELIBERATION OF REAL PROPERTY), AND SECTION 551.074 (PERSONNEL MATTERS)

Motion by Joe Ochoa, with a second by Michael Williamson, to enter into Executive Session to consult with board Attorney (Attorneys) on legal issues pertaining to Items 4C under Section 551.074, 4E under Section 551.074, and 6B under Section 551.071 of the Texas Government Code at 5:09 p.m. Motion carried unanimously.

- A. Review of applicants for the position of Executive Director for the Hidalgo County Regional Mobility Authority (Section 551.074 T.G.C.).

No action taken.

- B. Consultation with Attorney on legal issues pertaining to the advance project development of the 365 Tollway Segment 4, Section "A" West and Section "C" of the Hidalgo County Loop System (Section 551.071 T.G.C.).

No action taken.

- C. Consultation with Attorney on legal issues pertaining to a Memorandum of Understanding between the Hidalgo County Regional Mobility Authority and Hidalgo County for Section "A" West (Section 551.071 T.G.C.).

No action taken.

- D. Consultation with Attorney on legal issues pertaining to the Joint Use Agreement between Hidalgo County Irrigation District Number 2 and the Hidalgo County Regional Mobility Authority for the 365 Tollway Project (Section 551.071 T.G.C.).

No action taken.

- E. Consultation with Attorney on legal issues pertaining to that certain contract with Pulice Construction Inc. for the 365 Tollway Project.
No action taken.
- F. Consultation with Attorney on legal issues pertaining to Change Order Number 1-16 to that certain contract with Pulice Construction Inc. for the 365 Tollway Project (Section 551.071 T.G.C.).
No action taken.
- G. Consultation with Attorney on legal issues pertaining to the Financial Assistance Agreement with the Texas Department of Transportation for the 365 Tollway Project (Section 551.071 T.G.C.).
No action taken.
- H. Consultation with Attorney on legal issues pertaining to Professional Service Agreements for Inspection, Engineering, Surveying and Environmental Services to include construction material testing (Section 551.071 T.G.C.).
No action taken.
- I. Consultation with Attorney on legal issues pertaining to the voluntary acquisition of real property for various parcels for the 365 Tollway Project and International Bridge Trade Corridor Project (Sections 551.071 and 551.072 T.G.C.).
No action taken.
- J. Consultation with Attorney on legal issues pertaining to the acquisition, including the use of Eminent Domain, for property required to complete the project alignments of the 365 Tollway Project (Sections 551.071 and 551.072 T.G.C.).
No action taken.
- K. Consultation with Attorney on legal issues pertaining to rule making guidance for Board appointments (Section 551.071 T.G.C.).
No action taken.

**Motion by Joe Ochoa, with a second by Javier Peña, to reconvene the regular board meeting at 5:31 p.m.
Motion carried unanimously.**

ADJOURNMENT OF REGULAR MEETING

There being no other business to come before the Board of Directors, motion by Joe Ochoa, with a second by Michael Williamson, to adjourn the meeting at 5:32 p.m.

Juan Carlos Del Ángel, Vice Chairman

Attest:

Michael Williamson, Secretary/Treasurer

This Page
Intentionally
Left Blank

Item 3B

HIDALGO COUNTY REGIONAL MOBILITY AUTHORITY

AGENDA RECOMMENDATION FORM

BOARD OF DIRECTORS	<u> X </u>	AGENDA ITEM	<u> 3B </u>
PLANNING COMMITTEE	<u> </u>	DATE SUBMITTED	<u> 04/21/26 </u>
FINANCE COMMITTEE	<u> </u>	MEETING DATE	<u> 04/28/26 </u>
TECHNICAL COMMITTEE	<u> </u>		

1. Agenda Item: **APPROVAL OF PROJECT AND GENERAL EXPENSE REPORT FROM MARCH 7, 2026 TO APRIL 6, 2026**

2. Nature of Request: (Brief Overview) Attachments: X Yes No
Consideration and approval of project and general expense report for the period from March 7, 2026 to April 6, 2026

3. Policy Implication: Board Policy, Local Government Code, Texas Government Code, Texas Transportation Code, TxDOT Policy

4. Budgeted: X Yes No N/A Funding Source: VRF Bond

Operating Account	\$	274,495.83
Toll Revenue Series 2022A&B	\$	0.00
Disbursement Account	\$	1,820,405.09
VRF Series 2020A	\$	0.00
Total Project Expenses for Reporting Period	\$	2,094,900.92
Fund Balance after Expenses	\$	72,729,953

5. Staff Recommendation: **Motion to approve the project and general expense report for the March 7, 2026 to April 6, 2026, as presented.**

6. Planning Committee's Recommendation: Approved Disapproved X None

7. Finance Committee's Recommendation: Approved Disapproved X None

8. Board Attorney's Recommendation: Approved Disapproved X None

9. Chief Auditor's Recommendation: Approved Disapproved X None

10. Chief Financial Officer's Recommendation: X Approved Disapproved None

11. Chief Development Engineer's Recommendation: X Approved Disapproved None

12. Chief Construction Engineer's Recommendation: X Approved Disapproved None

13. Executive Director's Recommendation: X Approved Disapproved None



Memorandum

To: Robert L. Lozano, Chairman
From: Pilar Rodriguez, PE, Executive Director
Date: April 20, 2026
Re: **Expense Report for the Period from March 7, 2026 to April 6, 2026**

Attached is the expense report for the period commencing March 7, 2026 to April 6, 2026.

Expenses for the Operating Account total \$274,495.83, Toll Revenue Series 2022A&B total is \$0.00, Disbursement Account total \$1,820,405.09, and the VRF Series 2020A Account is \$0. The aggregate expense for the reporting period is \$2,094,900.92.

Based on review by this office, **approval of expenses for the reporting period is recommended in the aggregate amount of \$2,094,900.92.**

This leaves a fund balance (all funds) after expenses of \$72,729,953.

If you should have any questions or require additional information, please advise.



Mar. 7 - Apr. 6

April 2026

Plains Capital 41

Make Check Payable to	Inv Date	Amount	
WEX - Valero Fleet	4/15/2026	\$	1,510.95
City of Pharr	3/10/2026	\$	850.00
City of Pharr	4/8/2026	\$	5,635.20
City of Pharr	4/8/2026	\$	163,801.20
City of Pharr	4/8/2026	\$	205.00
City of Pharr	3/30/2026	\$	12,758.39
City of Pharr	3/30/2026	\$	12,758.39
City of Pharr	4/8/2026	\$	12,300.42
Pharr Economic Development Corporation	4/1/2026	\$	4,480.00
Bracewell, LLP	4/13/2026	\$	4,120.50
Pathfinder Public Affairs	3/31/2026	\$	10,000.00
Ruben Alfaro	3/26/2026	\$	404.46
Pena Designs	4/2/2026	\$	500.00
Credit Card Services	4/3/2026	\$	344.00
Credit Card Services	4/3/2026	\$	2,982.04
Credit Card Services	4/3/2026	\$	211.09
Law Office of Richard A. Cantu, P.C.	4/6/2026	\$	300.00
SmartCom	4/1/2026	\$	2,270.31
Sonia Lopez	4/1/2026	\$	200.00
A-Fast Delivery, LLC	4/1/2026	\$	126.00
Pharr Connect	4/1/2026	\$	750.00
Xerox Corporate - Xerox Financial Services	4/11/2026	\$	598.00
Xerox Corporate - Xerox Financial Services	4/11/2026	\$	219.46
Computer Repair Center	3/27/2026	\$	928.00
AV Plumbing LLC	4/9/2026	\$	6,489.50
Pavement Marking, Inc.	3/23/2026	\$	22,726.20
Bentley	4/19/2026	\$	6,950.00
Office Depot	4/15/2026	\$	76.72
		\$	274,495.83

Wilmington Trust 45/Capital Projects

Pulice Construction, Inc.	4/13/2026	\$	1,385,128.07
Bracewell, LLP	4/13/2026	\$	11,904.00
Law Office of Richard A. Cantu, P.C.	4/6/2026	\$	2,666.00
Schwab and Stroope, PLLC	4/1/2026	\$	1,683.00
Terracon Consultants, Inc.	4/7/2026	\$	125,833.48
Atlas Technical Consultants, LLC	4/1/2026	\$	12,285.92
Raba Kistner, Inc.	3/31/2026	\$	895.25
B2Z Engineering	4/6/2026	\$	6,555.94
HDR Engineering, Inc.	4/7/2026	\$	81,247.97
HDR Engineering, Inc.	4/7/2026	\$	53,111.98
HDR Engineering, Inc.	4/7/2026	\$	913.25
C&M Associates, Inc.	3/31/2026	\$	7,399.17
SWG Engineering, LLC	3/31/2026	\$	7,500.00
Alliance Geotechnical Group Inc.	2/28/2026	\$	87,992.45
Texas Department of Transportation	9/15/2025	\$	58.91
KCI Technologies, Inc.	2/20/2026	\$	33,229.70
AIM GIS Solutions	4/6/2026	\$	2,000.00
		\$	1,820,405.09

Sub Total - General -41 (Operating)	\$	274,495.83
Sub Total - Capital Projects-45 (Disbursement)	\$	1,820,405.09
	\$	2,094,900.92

Approved: _____
Robert L. Lozano, Chairman

Pilar Rodriguez PE, Executive Director

Approved: _____
Micheal J. Williamson, Secretary/Treasurer

4/28/2026

Item 3C

HIDALGO COUNTY REGIONAL MOBILITY AUTHORITY

AGENDA RECOMMENDATION FORM

BOARD OF DIRECTORS	<u> X </u>	AGENDA ITEM	<u> 3C </u>
PLANNING COMMITTEE	<u> </u>	DATE SUBMITTED	<u> 4/20/2026 </u>
FINANCE COMMITTEE	<u> </u>	MEETING DATE	<u> 4/28/2026 </u>
TECHNICAL COMMITTEE	<u> </u>		

1. Agenda Item: **APPROVAL OF THE FINANCIAL REPORT FOR THE MONTH OF FEBRUARY 2026.**

2. Nature of Request: (Brief Overview) Attachments: Yes No
Consideration and approval of financial reports for the month of February 2026.

3. Policy Implication: Board Policy, Local Government Code, Texas Government Code, Texas Transportation Code, TxDOT Policy

4. Budgeted: Yes No N/A

5. Staff Recommendation: **Motion to approve the Financial Reports for the month of February 2026, as presented.**

6. Program Manager's Recommendation: Approved Disapproved None
7. Planning Committee's Recommendation: Approved Disapproved None
8. Board Attorney's Recommendation: Approved Disapproved None
9. Chief Auditor's Recommendation: Approved Disapproved None
10. Chief Financial Officer's Recommendation: Approved Disapproved None
10. Chief Development Engineer's Recommendation: Approved Disapproved None
11. Chief Construction Engineer's Recommendation: Approved Disapproved None
12. Executive Director's Recommendation: Approved Disapproved None

**HIDALGO CO. REGIONAL MOBILITY AUTHORITY
STATEMENT OF NET POSITION FEBRUARY 28, 2026**

ASSETS

CURRENT ASSETS	
Cash & cash equivalents	\$ 13,744,466
Cash with fiscal agent-promises	122,502
Clearing Account-Receiveable	300,000
Accounts Receivable - VR Fees	584,100
Accounts Receivable - Promiles	18,225
Due from Cap Proj Fund	440
Prepaid expense	43,937
Prepaid bond insurances	252,766
	<hr/>
Total Current Assets	15,066,436
RESTRICTED ASSETS	
Cash & cash equivalents-Capital Projects	62,454,185
Accrued interest receivable-Capital Projects	1,250
Advance	2,513,637
Accrued interest receivable-Debt Svc	3,665
Investment-2020 debt service	1,138,930
Investment-debt service; 2022 A&B	3,464,890
Cash & equivalents-debt service reserves; 2022 A&B	20,872,482
	<hr/>
Total Restricted Assets	90,449,039
CAPITAL ASSETS	
Land-ROW	914,934
Land-environmental	441,105
Wetland Improvements	5,880,097
Leasehold improvements	409,547
Office equipment/other	40,946
Right to use-Bldg	437,340
Road-BSIF	3,010,637
Construction in progress	336,416,506
Accumulated depreciation	(899,030)
Accumulated amortization	(338,939)
	<hr/>
Total Capital Assets	346,313,143
TOTAL ASSETS	\$ 451,828,619

LIABILITIES AND NET POSITION

CURRENT LIABILITIES	
Accounts payable	\$ 599
Accounts payable-City of Pharr/	170,449
Accrued wages	61,680
Lease Payable	115,163
Arbitrage payable	41,165
Current portion of compensated absences	55,745
Unearned Revenue - Overweight Permit Escrow	122,502
Current Portion of Bond Premium 2020A	45,256
Current Portion of Bond Premium 2022 A	356,126
Current Portion of Bond Premium 2022 B	132,309
	<hr/>
Total Current Liabilities	1,100,994
RESTRICTED LIABILITIES	
Due Gen Fund	440
Current Portion of Long-Term 2020 Debt	2,365,000
Accrued bond interest payable	531,267
Retainage payable	409,804
	<hr/>
Total Restricted Liabilities	3,306,511
LONG-TERM LIABILITIES	
LT Compensated absences	381,993
2020 Series A Bonds Payable	9,870,000
2020 Series B Bonds Payable	48,550,000
2022 Series A Bonds Payable	163,818,475
2022 Series B Bonds Payable	69,281,104
Bond premium 2020A	1,074,828
Bond premium 2022A	10,654,096
Bond premium 2022B	3,958,240
	<hr/>
Total Long-Term Liabilities	307,588,736
	<hr/>
Total Liabilities	311,996,241
NET POSITION	
Investment in Capital Assets, Net of Related Debt	34,769,483
Restricted for:	
Debt Service	22,169,791
Capital projects	64,967,822
Unrestricted	17,925,282
	<hr/>
Total Net Position	139,832,378
TOTAL LIABILITIES AND NET POSITION	\$ 451,828,619



Pharr, TX

Balance Sheet

Account Summary

As Of 02/28/2026

Account	Name	Balance
Fund: 41 - HCRMA-GENERAL		
Assets		
41-1-1100-000	GENERAL OPERATING	93,240.45
41-1-1102-000	POOL INVESTMENTS	11,134,526.01
41-1-1102-001	INVESTMENT-ROAD MAINT,	1,186,960.81
41-1-1102-002	INVESTMENT-GENERAL	1,329,739.59
41-1-1110-000	CLEARING ACCOUNT-WT 000-VRF	300,000.00
41-1-1113-000	ACCOUNTS RECIEVABLES-VR FEES	584,100.00
41-1-1113-009	ACCOUNTS RECEIVABLE- PROMILES	18,225.00
41-1-1113-100	PROMILES-PREPAID/ESCROW OVERWE	122,501.56
41-1-1444-004	DUE FROM CAP. PROJ. FUND	440.38
41-1-1601-000	PREPAID EXPENSE	43,937.39
41-1-1601-001	PREPAID BOND INSURANCE	252,766.05
41-1-1910-001	LAND - RIGHT OF WAY	914,933.99
41-1-1910-002	LAND - ENVIORNMENTAL	441,105.00
41-1-1920-004	LEASEHOLD IMPROV.	409,547.22
41-1-1920-010	WETLAND IMPROV	5,880,097.35
41-1-1922-000	ACCUM DEPR - BUILDINGS	-259,829.01
41-1-1940-001	OFFICE FURNITURE & FIXTURES	32,339.94
41-1-1940-002	COMPUTER/SOFTWARE	8,606.51
41-1-1940-003	RIGHT TO USE- BLDG	437,340.00
41-1-1942-000	ACCUM DEPR - MACH & EQUIP	-34,427.21
41-1-1942-001	ACCUM AMORT-BLDG	-338,939.00
41-1-1950-001	ROADS - BSIF	3,010,636.97
41-1-1952-000	ACCUM DEPR - INFRASTRUCTURE	-604,774.48
41-1-1960-000	CONSTRUCTION IN PROGRESS	336,416,505.97
	Total Assets:	361,379,580.49
		<u>361,379,580.49</u>
Liability		
41-2-1212-000	ACCOUNTS PAYABLE	599.00
41-2-1212-001	A/P CITY OF PHARR	170,448.70
41-2-1212-007	ACCRUED WAGES	61,680.43
41-2-1212-010	LEASE PAYABLE	115,162.78
41-2-1212-011	ARBITRAGE PAYABLE	41,164.60
41-2-1213-007	CURRENT-UNAMORTIZED-PREM 2022 A	356,125.78
41-2-1213-008	CURRENT-UNAMORTIZED-PREM 2022 B	132,308.88
41-2-1213-010	CURRENT- UNAMORTIZED- PREM 2020A	45,255.92
41-2-1213-011	CURRENT PORTION OF COMP ABSENCES	55,745.00
41-2-1213-012	BONDS PAYABLE CURRENT- 2020B	2,365,000.00
41-2-1213-100	UNEARNED REV.-OVERWEIGHT	122,501.56
41-2-1214-004	UNAMORTIZED PREM- 2020A	1,074,828.10
41-2-1214-005	LT UNAMORTIZED PREM 2022 A	10,654,096.10
41-2-1214-006	LT UNAMORTIZED PREM 2022 B	3,958,240.34
41-2-1214-007	LT COMPENSATED ABSENCES	381,992.53
41-2-1214-011	LONG TERM BONDS- 2020A	9,870,000.00
41-2-1214-012	LONG TERM BONDS- 2020B	48,550,000.00
41-2-1214-013	LT BOND PAY 2022 A	163,818,474.65
41-2-1214-014	LT BOND PAY 2022 B	69,281,103.75
	Total Liability:	311,054,728.12
Equity		
41-3-3400-000	FUND BALANCE	51,304,117.14
	Total Beginning Equity:	51,304,117.14



Pharr, TX

Income Statement Account Summary

For Fiscal: 2026 RMA Period Ending: 02/28/2026

		Original Total Budget	Current Total Budget	MTD Activity	YTD Activity	Budget Remaining
Fund: 41 - HCRMA-GENERAL						
Revenue						
<u>41-4-1504-000</u>	VEHICLE REGISTRATION FEES	0.00	0.00	584,100.00	1,231,520.00	-1,231,520.00
<u>41-4-1505-005</u>	PROMILES-OW/OS PERMIT FEES	0.00	0.00	133,470.00	261,145.80	-261,145.80
<u>41-4-1506-000</u>	INTEREST REVENUE	0.00	0.00	39,265.79	87,825.24	-87,825.24
<u>41-4-4664-000</u>	MISCELLANEOUS	0.00	0.00	0.00	1,893.32	-1,893.32
	Revenue Total:	0.00	0.00	756,835.79	1,582,384.36	-1,582,384.36
Expense						
<u>41-52900-1100-000</u>	SALARIES	0.00	0.00	56,103.56	110,020.79	-110,020.79
<u>41-52900-1104-000</u>	OVERTIME	0.00	0.00	867.49	867.49	-867.49
<u>41-52900-1105-000</u>	FICA	0.00	0.00	4,332.75	8,425.95	-8,425.95
<u>41-52900-1106-000</u>	HEALTH INSURANCE	0.00	0.00	55.00	55.00	-55.00
<u>41-52900-1115-000</u>	EMPLOYEES RETIREMENT	0.00	0.00	6,985.47	13,835.56	-13,835.56
<u>41-52900-1116-000</u>	PHONE ALLOWANCE	0.00	0.00	392.30	784.60	-784.60
<u>41-52900-1117-000</u>	CAR ALLOWANCE	0.00	0.00	1,292.30	2,584.60	-2,584.60
<u>41-52900-1122-000</u>	EAP- ASSISTANCE PROGRAM	0.00	0.00	18.15	39.93	-39.93
<u>41-52900-1178-000</u>	ADMIN FEE	0.00	0.00	900.00	1,950.00	-1,950.00
<u>41-52900-1200-000</u>	OFFICE SUPPLIES	0.00	0.00	446.04	446.04	-446.04
<u>41-52900-1604-000</u>	MAINTENANCE & REPAIR	0.00	0.00	0.00	95.00	-95.00
<u>41-52900-1606-000</u>	UTILITIES	0.00	0.00	3,483.45	4,620.92	-4,620.92
<u>41-52900-1607-000</u>	CONTRACTUAL ADM/IT SERVICES	0.00	0.00	850.00	1,700.00	-1,700.00
<u>41-52900-1610-001</u>	SUBSCRIPTIONS-SOFTWARE	0.00	0.00	115.70	115.70	-115.70
<u>41-52900-1611-000</u>	POSTAGE/FEDEX/COURTIER	0.00	0.00	468.50	594.50	-594.50
<u>41-52900-1640-000</u>	ADVERTISING	0.00	0.00	4,355.00	4,355.00	-4,355.00
<u>41-52900-1662-000</u>	PRINTING & PUBLICATIONS	0.00	0.00	390.60	390.60	-390.60
<u>41-52900-1705-000</u>	ACCOUNTING FEES	0.00	0.00	205.00	205.00	-205.00
<u>41-52900-1710-000</u>	LEGAL FEES	0.00	0.00	3,054.00	3,054.00	-3,054.00
<u>41-52900-1710-001</u>	LEGAL FEES-GOV.AFFAIRS	0.00	0.00	10,000.00	10,000.00	-10,000.00
<u>41-52900-1715-000</u>	RENT-OFFICE	0.00	0.00	4,480.00	8,960.00	-8,960.00
<u>41-52900-1715-001</u>	RENT-OFFICE EQUIPMENT	0.00	0.00	1,382.07	1,980.07	-1,980.07
<u>41-52900-1715-002</u>	RENT-OTHER	0.00	0.00	118.80	118.80	-118.80
<u>41-52900-1716-000</u>	CONTRACTUAL WEBSITE SERVICES	0.00	0.00	500.00	500.00	-500.00
<u>41-52900-1731-000</u>	MISCELLANEOUS	0.00	0.00	0.00	4,000.00	-4,000.00
<u>41-52900-1999-006</u>	TRANS OUT- 2020 DEBT SVC	0.00	0.00	633,436.13	360,992.26	-360,992.26
<u>41-52900-1999-011</u>	TRANSFER OUT 2022 DEBT	0.00	0.00	8,000.00	1,787,248.00	-1,787,248.00
<u>41-53000-1100-000</u>	SALARIES	0.00	0.00	60,011.34	118,872.46	-118,872.46
<u>41-53000-1104-000</u>	OVERTIME	0.00	0.00	8,241.89	12,891.88	-12,891.88
<u>41-53000-1105-000</u>	FICA	0.00	0.00	5,199.84	10,036.90	-10,036.90
<u>41-53000-1115-000</u>	EMPLOYEES RETIREMENT	0.00	0.00	8,859.79	17,104.05	-17,104.05
<u>41-53000-1116-000</u>	PHONE ALLOWANCE	0.00	0.00	646.10	1,292.20	-1,292.20
<u>41-53000-1117-000</u>	CAR ALLOWANCE	0.00	0.00	1,107.68	2,215.36	-2,215.36
<u>41-53000-1122-000</u>	EAP- ASSISTANCE PROGRAM	0.00	0.00	25.41	50.82	-50.82
<u>41-53000-1178-000</u>	ADMN FEE	0.00	0.00	1,200.00	2,400.00	-2,400.00
<u>41-53000-1200-000</u>	OFFICE SUPPLIES	0.00	0.00	72.80	318.74	-318.74
<u>41-53000-1201-000</u>	SMALL TOOLS	0.00	0.00	58.65	58.65	-58.65
<u>41-53000-1605-000</u>	JANITORIAL	0.00	0.00	200.00	400.00	-400.00
<u>41-53000-1606-001</u>	UTILITIES	0.00	0.00	58.10	58.10	-58.10
<u>41-53000-1608-000</u>	UNIFORMS	0.00	0.00	0.00	130.00	-130.00
<u>41-53000-1610-000</u>	DUES & SUBSCRIPTIONS	0.00	0.00	620.00	620.00	-620.00
<u>41-53000-1610-001</u>	SUBSCRIPTIONS - SOFTWARE	0.00	0.00	0.00	22,500.00	-22,500.00
<u>41-53000-1640-000</u>	ADVERTISING	0.00	0.00	420.00	798.00	-798.00
<u>41-53000-1650-000</u>	TRAINING	0.00	0.00	250.00	250.00	-250.00
<u>41-53000-1715-001</u>	RENTAL - OFFICE EQUIPMENT	0.00	0.00	219.46	438.92	-438.92

Income Statement

For Fiscal: 2026 RMA Period Ending: 02/28/2026

		Original Total Budget	Current Total Budget	MTD Activity	YTD Activity	Budget Remaining
<u>41-53000-1715-010</u>	VEHICLE RENTAL	0.00	0.00	5,635.20	11,270.40	-11,270.40
<u>41-53000-1715-012</u>	VEHICLE MAINTENANCE	0.00	0.00	98.94	98.94	-98.94
<u>41-53000-1715-013</u>	VEHICLE FUEL	0.00	0.00	1,001.74	1,001.74	-1,001.74
<u>41-54000-1100-000</u>	SALARIES	0.00	0.00	11,092.30	22,023.07	-22,023.07
<u>41-54000-1105-000</u>	FICA	0.00	0.00	848.92	1,685.49	-1,685.49
<u>41-54000-1115-000</u>	EMPLOYEES RETIREMENT	0.00	0.00	1,523.64	3,026.32	-3,026.32
<u>41-54000-1116-000</u>	PHONE ALLOWANCE	0.00	0.00	92.30	184.60	-184.60
<u>41-54000-1117-000</u>	CAR ALLOWANCE	0.00	0.00	553.84	1,107.68	-1,107.68
<u>41-54000-1122-000</u>	EAP- ASSISTANCE PROGRAM	0.00	0.00	3.63	7.26	-7.26
<u>41-54000-1178-000</u>	ADMN FEE	0.00	0.00	150.00	300.00	-300.00
<u>41-54000-1650-000</u>	TRAINING	0.00	0.00	495.00	495.00	-495.00
<u>41-54000-1660-000</u>	TRAVEL	0.00	0.00	497.80	497.80	-497.80
<u>41-58000-1606-002</u>	UTILITIES - BSIF	0.00	0.00	74.94	74.94	-74.94
<u>41-59000-1606-002</u>	COMMUNICATIONS	0.00	0.00	750.00	1,500.00	-1,500.00
	Expense Total:	0.00	0.00	852,241.62	2,561,649.13	-2,561,649.13
	Fund: 41 - HCRMA-GENERAL Surplus (Deficit):	0.00	0.00	-95,405.83	-979,264.77	
	Total Surplus (Deficit):	0.00	0.00	-95,405.83	-979,264.77	



Pharr, TX

Bank Statement Register

GENERAL OPERATING

Period 2/1/2026 - 2/28/2026

Packet: BRPKT06066

Bank Statement

Beginning Balance	306,211.55
Plus Debits	450,543.87
Less Credits	646,635.14
Adjustments	0.00
Ending Balance	110,120.28

General Ledger

Account Balance	93,240.45
Less Outstanding Debits	0.00
Plus Outstanding Credits	16,879.83
Adjustments	0.00
Adjusted Account Balance	110,120.28

03/26/26

Statement Ending Balance	110,120.28
Bank Difference	0.00
General Ledger Difference	0.00

CASH BALANCE CONSISTS OF THE FOLLOWING GENERAL LEDGER ACCOUNTS

41-1-1100-000 GENERAL OPERATING

Cleared Deposits

Item Date	Reference	Item Type	Description	Amount
02/28/2026	<u>DEP0123178</u>	Deposit	TO RECORD MO DIST	316,923.87
02/28/2026	<u>DEP0123441</u>	Deposit	TO RECORD PROMILES REV FUND 41 HCRM	32,280.30
02/28/2026	<u>DEP0123444</u>	Deposit	TO RECORD PROMILES REV FUND 41 HCRM	30,491.10
02/28/2026	<u>DEP0123445</u>	Deposit	TO RECORD PROMILES REV FUND 41 HCRM	33,675.30
02/28/2026	<u>DEP0123446</u>	Deposit	TO RECORD PROMILES REV FUND 41 HCRM	37,023.30
Total Cleared Deposits (5)				450,393.87

Cleared Checks

Item Date	Reference	Item Type	Description	Amount
01/29/2026	<u>2997</u>	Check	A FAST DELIVERY	-126.00
01/29/2026	<u>2998</u>	Check	ADVANCE PUBLISHING LLC	-378.00
01/29/2026	<u>3000</u>	Check	ALLTERRA CENTRAL, INC.	-1,000.00
01/29/2026	<u>3001</u>	Check	CITY OF MCALLEN	-2,500.00
01/29/2026	<u>3002</u>	Check	CITY OF PHARR	-750.00
01/29/2026	<u>3003</u>	Check	INFO TECH	-21,500.00
01/29/2026	<u>3004</u>	Check	OFFICE DEPOT	-245.94
01/29/2026	<u>3005</u>	Check	SMARTCOM TELEPHONE LLC	-1,137.47
01/29/2026	<u>3006</u>	Check	SONIA LOPEZ	-200.00
01/29/2026	<u>3007</u>	Check	XEROX CORPORATION	-817.46
02/09/2026	<u>3008</u>	Check	EDUARDO C GARCIA	-150.00
02/10/2026	<u>3009</u>	Check	EDUARDO C GARCIA	-150.00
Total Cleared Checks (12)				-28,954.87

Cleared Other

Item Date	Reference	Item Type	Description	Amount
02/01/2026	DFT0015513	Bank Draft	PHARR ECONOMIC DEVELOPMENT CORPOR	-4,480.00
02/06/2026	DFT0015517	Bank Draft	LAW OFFICE OF RICHARD A. CANTU	-270.00
02/09/2026	3008	Check Reversal	EDUARDO C GARCIA Reversal	150.00
02/10/2026	DFT0015509	Bank Draft	CITY OF PHARR	-850.00
02/11/2026	DFT0015514	Bank Draft	BRACEWELL LLP ATTORNEYS AT LAW	-2,784.00
02/12/2026	DFT0015510	Bank Draft	CITY OF PHARR	-5,635.20
02/12/2026	DFT0015511	Bank Draft	CITY OF PHARR	-161,258.31
02/12/2026	DFT0015512	Bank Draft	CITY OF PHARR	-205.00
02/15/2026	DFT0015508	Bank Draft	VALERO FLEET	-1,001.74
02/28/2026	DFT0015515	Bank Draft	PATHFINDER PUBLIC AFFAIRS	-10,000.00
02/28/2026	DFT0015516	Bank Draft	PENA DESIGNS	-500.00
02/28/2026	EFT0008227	EFT	TO RECORD WIRE TRANSFER HIDALGO CO	-425,000.00
02/28/2026	EFT0008234	EFT	CREDIT CARD SERVICES HCRMA FUND 41	-165.00
02/28/2026	EFT0008235	EFT	CREDIT CARD SERVICES HCRMA FUND 41	-3,601.72
02/28/2026	EFT0008236	EFT	CREDIT CARD SERVICES HCRMA FUND 41	-1,929.30
Total Cleared Other (15)				-617,530.27

Outstanding Checks

Item Date	Reference	Item Type	Description	Amount
01/29/2026	2999	Check	ALAN YODER ENTERPRISES INC	-95.00
02/25/2026	3010	Check	A FAST DELIVERY	-136.50
02/25/2026	3011	Check	ADVANCE PUBLISHING LLC	-420.00
02/25/2026	3012	Check	AIM MEDIA TEXAS BUSINESS OFFICE	-1,856.00
02/25/2026	3013	Check	CITY OF PHARR	-750.00
02/25/2026	3014	Check	OFFICE DEPOT	-165.26
02/25/2026	3015	Check	SMARTCOM TELEPHONE LLC	-3,264.94
02/25/2026	3016	Check	SONIA LOPEZ	-200.00
02/25/2026	3017	Check	UBEO MIDCO, LLC	-390.60
02/25/2026	3018	Check	WILMINGTON TRUST FEE COLLECTIONS	-8,000.00
02/25/2026	3019	Check	XEROX BUSINESS SOLUTIONS SOUTHWES	-784.07
02/25/2026	3020	Check	XEROX CORPORATION	-817.46
Total Outstanding Checks (12)				-16,879.83



Pharr, TX

Bank Statement Register

POOL INVESTMENTS

Period 2/1/2026 - 2/28/2026

Packet: BRPKT06056

03/26/26

Bank Statement

Beginning Balance	10,677,588.90
Plus Debits	460,393.59
Less Credits	3,456.48
Adjustments	0.00
Ending Balance	11,134,526.01

General Ledger

Account Balance	11,134,526.01
Less Outstanding Debits	0.00
Plus Outstanding Credits	0.00
Adjustments	0.00
Adjusted Account Balance	11,134,526.01

Statement Ending Balance	11,134,526.01
Bank Difference	0.00
General Ledger Difference	0.00

CASH BALANCE CONSISTS OF THE FOLLOWING GENERAL LEDGER ACCOUNTS

41-1-1102-000 POOL INVESTMENTS

Cleared Deposits

Item Date	Reference	Item Type	Description	Amount
02/28/2026	DEP0123319	Deposit	TO RECORD INTEREST FUND 41 HCRMA FE	31,937.11
02/28/2026	DEP0123320	Deposit	TO RECORD INTEREST FUND 41 HCRMA FE	3,456.48
02/28/2026	DEP0123340	Deposit	TO RECORD WIRE TRANSFER HIDALGO CO	425,000.00
Total Cleared Deposits (3)				460,393.59

Cleared Other

Item Date	Reference	Item Type	Description	Amount
02/28/2026	EFT0008226	EFT	TO REVERSE INTEREST HCRMA FEB 2026	-3,456.48
Total Cleared Other (1)				-3,456.48



Pharr, TX

Bank Statement Register

RMA LOGIC ROAD MAINT

Period 2/1/2026 - 2/28/2026

Packet: BRPKT06057

03/26/26

Bank Statement

Beginning Balance	1,183,504.33
Plus Debits	3,456.48
Less Credits	0.00
Adjustments	0.00
Ending Balance	1,186,960.81

General Ledger

Account Balance	1,186,960.81
Less Outstanding Debits	0.00
Plus Outstanding Credits	0.00
Adjustments	0.00
Adjusted Account Balance	1,186,960.81

Statement Ending Balance	1,186,960.81
Bank Difference	0.00
General Ledger Difference	0.00

CASH BALANCE CONSISTS OF THE FOLLOWING GENERAL LEDGER ACCOUNTS

41-1-1102-001 INVESTMENT-ROAD MAINT,

Cleared Deposits

Item Date	Reference	Item Type	Description	Amount
02/28/2026	<u>DEP0123321</u>	Deposit	TO RECORD INTEREST FUND 41 HCRMA FE	3,456.48
Total Cleared Deposits (1)				3,456.48



Pharr, TX

Bank Statement Register

INVESTMENT-GENERAL

Period 2/1/2026 - 2/28/2026

Packet: BRPKT06058

Bank Statement

Beginning Balance	1,325,867.39
Plus Debits	3,872.20
Less Credits	0.00
Adjustments	0.00
Ending Balance	1,329,739.59

General Ledger

Account Balance	1,329,739.59
Less Outstanding Debits	0.00
Plus Outstanding Credits	0.00
Adjustments	0.00
Adjusted Account Balance	1,329,739.59

03/26/26

Statement Ending Balance	1,329,739.59
Bank Difference	0.00
General Ledger Difference	0.00

CASH BALANCE CONSISTS OF THE FOLLOWING GENERAL LEDGER ACCOUNTS

41-1-1102-002 INVESTMENT-GENERAL

Cleared Deposits

Item Date	Reference	Item Type	Description	Amount
02/28/2026	<u>DEP0123177</u>	Deposit	TO RECORD INTEREST FUND 41 HCRMA FE	3,872.20
Total Cleared Deposits (1)				3,872.20



Pharr, TX

Balance Sheet

Account Summary

As Of 02/28/2026

Account	Name	Balance	
Fund: 42 - HCRMA-DEBT SERVICE			
Assets			
<u>42-1-1102-002</u>	INVESTMENTS D/S 2022 A SERIES	1,981,753.70	
<u>42-1-1102-003</u>	INVESTMENTS D/S2022 B SERIES	1,481,483.43	
<u>42-1-1102-004</u>	INVESTMENT SR 2022A	0.28	
<u>42-1-1102-010</u>	INVESTMENTS RESERVE D/S 2022 A SERIE	14,385,261.88	
<u>42-1-1102-011</u>	INVESTMENTS RESERVE D/S 2022 B SERIE	6,487,836.18	
<u>42-1-1102-012</u>	INVESTMENT JR LIEN REV BDS 2022B	1,036.95	
<u>42-1-1113-012</u>	ACCRUED INTEREST	3,665.05	
<u>42-1-4105-002</u>	DEBT SERVICE- 2020 SERIES	1,138,929.89	
	Total Assets:	25,479,967.36	<u>25,479,967.36</u>
Liability			
<u>42-2-4214-007</u>	ACCRUED INTEREST PAY- 2020 SERIES	133,413.00	
<u>42-2-4214-008</u>	ACCRUED INTEREST PAY - 2022 A SERIES	274,658.00	
<u>42-2-4214-009</u>	ACCRUED INTEREST PAY 2022 B SERIES	123,196.00	
	Total Liability:	531,267.00	
Equity			
<u>42-3-4400-000</u>	FUND BALANCE	22,369,473.35	
	Total Beginning Equity:	22,369,473.35	
Total Revenue		2,579,227.01	
Total Expense		0.00	
Revenues Over/Under Expenses		2,579,227.01	
	Total Equity and Current Surplus (Deficit):	24,948,700.36	
	Total Liabilities, Equity and Current Surplus (Deficit):		<u>25,479,967.36</u>



Pharr, TX

Income Statement

Account Summary

For Fiscal: 2026 RMA Period Ending: 02/28/2026

		Original Total Budget	Current Total Budget	MTD Activity	YTD Activity	Budget Remaining
Fund: 42 - HCRMA-DEBT SERVICE						
Revenue						
<u>42-4-1506-002</u>	INTEREST 2020 SERIES	0.00	0.00	1,714.34	2,600.19	-2,600.19
<u>42-4-1506-003</u>	INTEREST 2022 A SERIES	0.00	0.00	4,689.69	7,385.70	-7,385.70
<u>42-4-1506-004</u>	INTEREST 2022 B SERIES	0.00	0.00	83.99	170.28	-170.28
<u>42-4-1506-010</u>	INTEREST RESERVE 2022 A SERIES	0.00	0.00	41,800.26	88,787.04	-88,787.04
<u>42-4-1506-011</u>	INTEREST RESERVE 2022 B SERIES	0.00	0.00	18,892.78	40,043.54	-40,043.54
<u>42-4-1999-000</u>	TRANSFERS IN-FROM GENERAL FUND	0.00	0.00	330,496.13	2,440,240.26	-2,440,240.26
	Revenue Total:	0.00	0.00	397,677.19	2,579,227.01	-2,579,227.01
	Fund: 42 - HCRMA-DEBT SERVICE Total:	0.00	0.00	397,677.19	2,579,227.01	
	Total Surplus (Deficit):	0.00	0.00	397,677.19	2,579,227.01	



Pharr, TX

Bank Statement Register

INVESTMENT D/S 2022A SERIES

Period 2/1/2026 - 2/28/2026

Packet: BRPKT06059

Bank Statement

Beginning Balance	1,977,064.01
Plus Debits	4,689.69
Less Credits	0.00
Adjustments	0.00
Ending Balance	1,981,753.70

General Ledger

Account Balance	1,981,753.70
Less Outstanding Debits	0.00
Plus Outstanding Credits	0.00
Adjustments	0.00
Adjusted Account Balance	1,981,753.70

03/26/26

Statement Ending Balance	1,981,753.70
Bank Difference	0.00
General Ledger Difference	0.00

CASH BALANCE CONSISTS OF THE FOLLOWING GENERAL LEDGER ACCOUNTS

42-1-1102-002 INVESTMENTS D/S 2022 A SERIES

Cleared Deposits

Item Date	Reference	Item Type	Description	Amount
02/28/2026	<u>DEP0123280</u>	Deposit	TO RECORD INTEREST FUND 42 HCRMA FE	4,689.69
Total Cleared Deposits (1)				4,689.69



Pharr, TX

Bank Statement Register

INVESTMENT D/S 2022B SERIES

Period 2/1/2026 - 2/28/2026

Packet: BRPKT06060

03/26/26

Bank Statement

Beginning Balance	1,481,402.28
Plus Debits	81.15
Less Credits	0.00
Adjustments	0.00
Ending Balance	1,481,483.43

General Ledger

Account Balance	1,481,483.43
Less Outstanding Debits	0.00
Plus Outstanding Credits	0.00
Adjustments	0.00
Adjusted Account Balance	1,481,483.43

Statement Ending Balance	1,481,483.43
Bank Difference	0.00
General Ledger Difference	0.00

CASH BALANCE CONSISTS OF THE FOLLOWING GENERAL LEDGER ACCOUNTS

42-1-1102-003 INVESTMENTS D/S2022 B SERIES

Cleared Deposits

Item Date	Reference	Item Type	Description	Amount
02/28/2026	<u>DEP0123281</u>	Deposit	TO RECORD INTEREST FUND 42 HCRMA FE	81.15
Total Cleared Deposits (1)				81.15



Pharr, TX

Bank Statement Register

INVESTMENT RESERVE D/S 2022A SERIES

Period 2/1/2026 - 2/28/2026

Packet: BRPKT06061

Bank Statement

Beginning Balance	14,343,461.62
Plus Debits	41,800.26
Less Credits	0.00
Adjustments	0.00
Ending Balance	14,385,261.88

General Ledger

Account Balance	14,385,261.88
Less Outstanding Debits	0.00
Plus Outstanding Credits	0.00
Adjustments	0.00
Adjusted Account Balance	14,385,261.88

03/26/26

Statement Ending Balance	14,385,261.88
Bank Difference	0.00
General Ledger Difference	0.00

CASH BALANCE CONSISTS OF THE FOLLOWING GENERAL LEDGER ACCOUNTS

42-1-1102-010 INVESTMENTS RESERVE D/S 2022 A SERIES

Cleared Deposits

Item Date	Reference	Item Type	Description	Amount
02/28/2026	<u>DEP0123282</u>	Deposit	TO RECORD INTEREST HCRMA FEB 2026	41,800.26
Total Cleared Deposits (1)				41,800.26



Pharr, TX

Bank Statement Register

INVESTMENT RESERVE D/S 2022B SERIES

Period 2/1/2026 - 2/28/2026

Packet: BRPKT06062

Bank Statement

Beginning Balance	6,468,943.40
Plus Debits	18,892.78
Less Credits	0.00
Adjustments	0.00
Ending Balance	6,487,836.18

General Ledger

Account Balance	6,487,836.18
Less Outstanding Debits	0.00
Plus Outstanding Credits	0.00
Adjustments	0.00
Adjusted Account Balance	6,487,836.18

03/26/26

Statement Ending Balance	6,487,836.18
Bank Difference	0.00
General Ledger Difference	0.00

CASH BALANCE CONSISTS OF THE FOLLOWING GENERAL LEDGER ACCOUNTS

42-1-1102-011 INVESTMENTS RESERVE D/S 2022 B SERIES

Cleared Deposits

Item Date	Reference	Item Type	Description	Amount
02/28/2026	<u>DEP0123283</u>	Deposit	TO RECORD INTEREST HCRMA FEB 2026	18,892.78
Total Cleared Deposits (1)				18,892.78



Pharr, TX

Bank Statement Register

INVESTMENT JR LIEN REV BDS 2022B

Period 2/1/2026 - 2/28/2026

Packet: BRPKT06063

Bank Statement

Beginning Balance	1,034.11
Plus Debits	2.84
Less Credits	0.00
Adjustments	0.00
Ending Balance	1,036.95

General Ledger

Account Balance	1,036.95
Less Outstanding Debits	0.00
Plus Outstanding Credits	0.00
Adjustments	0.00
Adjusted Account Balance	1,036.95

03/26/26

Statement Ending Balance	1,036.95
Bank Difference	0.00
General Ledger Difference	0.00

CASH BALANCE CONSISTS OF THE FOLLOWING GENERAL LEDGER ACCOUNTS

42-1-1102-012 INVESTMENT JR LIEN REV BDS 2022B

Cleared Deposits

Item Date	Reference	Item Type	Description	Amount
02/28/2026	<u>DEP0123284</u>	Deposit	TO RECORD INTEREST HCRMA FEB 2026	2.84
Total Cleared Deposits (1)				2.84



Pharr, TX

Bank Statement Register

INVESTMENTS D/S 2020 SERIES -

Period 2/1/2026 - 2/28/2026

Packet: BRPKT06064

Bank Statement

Beginning Balance	806,719.42
Plus Debits	332,210.47
Less Credits	0.00
Adjustments	0.00
Ending Balance	1,138,929.89

General Ledger

Account Balance	1,138,929.89
Less Outstanding Debits	0.00
Plus Outstanding Credits	0.00
Adjustments	0.00
Adjusted Account Balance	1,138,929.89

03/26/26

Statement Ending Balance	1,138,929.89
Bank Difference	0.00
General Ledger Difference	0.00

CASH BALANCE CONSISTS OF THE FOLLOWING GENERAL LEDGER ACCOUNTS

42-1-4105-002 DEBT SERVICE- 2020 SERIES

Cleared Deposits

Item Date	Reference	Item Type	Description	Amount
02/28/2026	<u>DEP0123317</u>	Deposit	TO RECORD FEB INTEREST HCRMA FEB 20.	1,714.34
02/28/2026	<u>DEP0123318</u>	Deposit	TO RECORD TRANSF IN - GEN FUND	330,496.13
Total Cleared Deposits (2)				332,210.47



Pharr, TX

Balance Sheet

Account Summary

As Of 02/28/2026

Account	Name	Balance	
Fund: 45 - HCRMA - CAP.PROJECTS FUND			
Assets			
<u>45-1-1102-000</u>	Pool Investment	62,454,185.49	
<u>45-1-1113-012</u>	ACCRUED INTEREST	1,249.98	
<u>45-1-1267-000</u>	ADVANCE	2,513,637.48	
	Total Assets:	64,969,072.95	<u>64,969,072.95</u>
Liability			
<u>45-2-1212-004</u>	DUE TO GENERAL FUND	440.38	
<u>45-2-1212-009</u>	RETAINAGE PAYABLE	409,804.25	
	Total Liability:	410,244.63	
Equity			
<u>45-3-1400-000</u>	Fund Balance	67,036,021.99	
	Total Beginning Equity:	67,036,021.99	
Total Revenue		397,738.87	
Total Expense		2,874,932.54	
Revenues Over/Under Expenses		-2,477,193.67	
	Total Equity and Current Surplus (Deficit):	64,558,828.32	
	Total Liabilities, Equity and Current Surplus (Deficit):		<u>64,969,072.95</u>



Pharr, TX

Income Statement

Account Summary

For Fiscal: 2026 RMA Period Ending: 02/28/2026

		Original Total Budget	Current Total Budget	MTD Activity	YTD Activity	Budget Remaining
Fund: 45 - HCRMA - CAP.PROJECTS FUND						
Revenue						
<u>45-4-1506-000</u>	Interest Revenue	0.00	0.00	186,635.45	397,738.87	-397,738.87
	Revenue Total:	0.00	0.00	186,635.45	397,738.87	-397,738.87
Expense						
<u>45-52900-8800-000</u>	Consulting & Engineering	0.00	0.00	577,726.68	577,726.68	-577,726.68
<u>45-52900-8810-004</u>	365 UTILITIES RELOCATION	0.00	0.00	263,371.71	263,371.71	-263,371.71
<u>45-52900-8820-003</u>	IBTC - ROW	0.00	0.00	0.00	1,450.00	-1,450.00
<u>45-52900-8841-000</u>	LEGAL FEES	0.00	0.00	15,063.00	15,063.00	-15,063.00
<u>45-52900-8844-000</u>	365 CONSTRUCTION FEDERAL	0.00	0.00	1,551,875.45	1,551,875.45	-1,551,875.45
<u>45-52900-8860-000</u>	365 TOLL SYSTEM	0.00	0.00	465,445.70	465,445.70	-465,445.70
	Expense Total:	0.00	0.00	2,873,482.54	2,874,932.54	-2,874,932.54
	Fund: 45 - HCRMA - CAP.PROJECTS FUND Surplus (Deficit):	0.00	0.00	-2,686,847.09	-2,477,193.67	
	Total Surplus (Deficit):	0.00	0.00	-2,686,847.09	-2,477,193.67	



Pharr, TX

Bank Statement Register

Pool Investment

Period 2/1/2026 - 2/28/2026

Packet: BRPKT06065

Bank Statement

Beginning Balance	64,062,786.23
Plus Debits	1,264,881.80
Less Credits	2,873,482.54
Adjustments	0.00
Ending Balance	62,454,185.49

General Ledger

Account Balance	62,454,185.49
Less Outstanding Debits	0.00
Plus Outstanding Credits	0.00
Adjustments	0.00
Adjusted Account Balance	62,454,185.49

03/26/26

Statement Ending Balance	62,454,185.49
Bank Difference	0.00
General Ledger Difference	0.00

CASH BALANCE CONSISTS OF THE FOLLOWING GENERAL LEDGER ACCOUNTS

45-1-1102-000 Pool Investment

Cleared Deposits

Item Date	Reference	Item Type	Description	Amount
02/28/2026	<u>DEP0123391</u>	Deposit	TO RECORD INTEREST FUND 45 HCRMA FE	186,635.45
02/28/2026	<u>DEP0123392</u>	Deposit	TO RECORD TXDOT REIMB #45	1,078,246.35
Total Cleared Deposits (2)				1,264,881.80

Cleared Other

Item Date	Reference	Item Type	Description	Amount
02/01/2026	<u>DFT0015500</u>	Bank Draft	SCHWAB & STROOPE, PLLC	-2,277.00
02/03/2026	<u>DFT0015502</u>	Bank Draft	ATLAS TECHNICAL CONSULTANTS LLC	-18,637.02
02/04/2026	<u>DFT0015503</u>	Bank Draft	RABA KISTNER	-8,671.04
02/05/2026	<u>DFT0015505</u>	Bank Draft	HDR	-34,615.74
02/05/2026	<u>DFT0015506</u>	Bank Draft	HDR	-57,799.72
02/05/2026	<u>DFT0015507</u>	Bank Draft	HDR	-10,791.71
02/06/2026	<u>DFT0015499</u>	Bank Draft	LAW OFFICE OF RICHARD A. CANTU	-1,519.00
02/06/2026	<u>DFT0015501</u>	Bank Draft	TERRACON	-50,901.86
02/06/2026	<u>DFT0015504</u>	Bank Draft	B2Z ENGINEERING LLC	-1,216.92
02/12/2026	<u>DFT0015498</u>	Bank Draft	BRACEWELL LLP ATTORNEYS AT LAW	-7,392.00
02/18/2026	<u>DFT0015496</u>	Bank Draft	PULICE CONSTRUCTION INC	-1,551,875.45
02/28/2026	<u>DFT0015497</u>	Bank Draft	SICE, INC	-396,854.27
02/28/2026	<u>EFT0008230</u>	EFT	TO RECORD CHECK PAID TO ALLICANCE G	-404,747.60
02/28/2026	<u>EFT0008231</u>	EFT	TO RECORD CHECK PAID TO ECS SOUTHW	-58,936.50
02/28/2026	<u>EFT0008232</u>	EFT	TO RECORD CHECK PAID TO SWG ENGINEI	-3,875.00

Cleared Other

Item Date	Reference	Item Type	Description	Amount
02/28/2026	<u>EFT0008233</u>	EFT	TO RECORD CHECK PAID TO MAGIC VALLE	-263,371.71
			Total Cleared Other (16)	-2,873,482.54

This Page
Intentionally
Left Blank

Item 3D

HIDALGO COUNTY REGIONAL MOBILITY AUTHORITY

AGENDA RECOMMENDATION FORM

BOARD OF DIRECTORS	<u> X </u>	AGENDA ITEM	<u> 3D </u>
PLANNING COMMITTEE	<u> </u>	DATE SUBMITTED	<u> 04/20/2026 </u>
FINANCE COMMITTEE	<u> </u>	MEETING DATE	<u> 04/28/2026 </u>
TECHNICAL COMMITTEE	<u> </u>		

1. Agenda Item: **APPROVAL OF QUARTERLY INVESTMENT REPORT FOR THE PERIOD ENDING MARCH 31, 2026.**

2. Nature of Request: (Brief Overview) Attachments: X Yes No
Consideration and approval of the quarterly investment reports for the period ending March 31, 2026.

3. Policy Implication: Board Policy, Local Government Code, Texas Government Code, Public Funds Investment Act Section 2256

4. Budgeted: Yes No X N/A

5. Staff Recommendation: **Motion to approve the Quarterly Investment Report for the period ending March 31, 2026, as presented**

6. Planning Committee's Recommendation: Approved Disapproved X None

7. Board Attorney's Recommendation: Approved Disapproved X None

8. Chief Auditor's Recommendation: Approved Disapproved X None

9. Chief Financial Officer's Recommendation: X Approved Disapproved None

10. Chief Development Engineer's Recommendation: Approved Disapproved X None

11. Chief Construction Engineer's Recommendation: Approved Disapproved X None

12. Executive Director's Recommendation: X Approved Disapproved None



Board of Directors

Robert L. Lozano, Chairman
Juan Carlos Del Ángel, Vice-Chairman
Michael J. Williamson, Secretary/Treasurer
Jose Maria "Joe" Ochoa, Director
Joe Daniel Olivarez, Director
Javier Peña, Director
Nick Rhodes, Director

April 9, 2026

To: Robert L. Lozano, Chairman
Members of the Board of Directors

From: Pilar Rodriguez, Executive Director/Investment Officer

RE: Quarterly Investment Report for Quarter Ending March 31, 2026, Statement of Compliance

The above-referenced report is hereby presented, pursuant to the Public Funds Investment Act (PFIA), for your review and acceptance.

This quarter investment disbursements totaled \$6,785,507 consisting of project construction. Other sources included: net internal transfers totaling \$1,616,486; contributions from (TxDOT Grant)--\$1,667,271; and total interest earned was \$948,426.

The PFIA also requires that the report contains a Statement of Compliance, signed by the Investment Officer, as presented below:

STATEMENT OF COMPLIANCE

This report complies with the requirements of the Public Investment Act as well as the Hidalgo County Regional Mobility Authority's (RMA) adopted investment policy. The RMA follows all provisions of the Public Investment Act and the RMA's investment policy.

Presented by RMA Investment Officers:

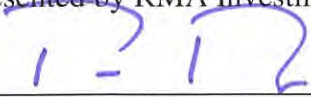

Pilar Rodriguez, Investment Officer



Jose H. Castillo, Investment Officer

HIDALGO COUNTY REGIONAL MOBILITY AUTHORITY
QUARTERLY INVESTMENT SUMMARY REPORT
Quarter Ending March 31, 2026

	<u>Local Govt. Investment Pool</u>	<u>Government (Federated) Securities</u>	<u>Total</u>
COST			
Beginning Balance	\$ 100,447,485	\$ 2,575,596	\$ 103,023,081
Additions:			
Interfund Transfers-in(out)	(1,154,250)	2,770,736	1,616,486
Contributions	-	1,667,271	1,667,271
Investment earnings-LOGIC	922,187	-	922,187
Investment earnings-Wilmington Trust	-	26,239	26,239
Deductions:			
Construction and related expenses	<u>(5,280,514)</u>	<u>(1,504,993)</u>	<u>(6,785,507)</u>
Ending Balance	<u>\$ 94,934,908</u>	<u>\$ 5,534,849</u>	<u>\$ 100,469,757</u>
 MARKET VALUE			
Beginning Balance	<u>\$ 100,466,246</u>	<u>\$ 2,575,596</u>	<u>\$ 103,041,842</u>
Ending Balance	<u>\$ 94,917,333</u>	<u>\$ 5,534,849</u>	<u>\$ 100,452,182</u>
 Weighted Average Maturity- Logic/Gov. Sec.	 47	 30	
Logic/Gov Sec. Weighted Average Yield	3.82%	3.32%	

**HIDALGO COUNTY REGIONAL MOBILITY AUTHORITY
HOLDINGS BY INVESTMENTS
QUARTERLY INVESTMENT REPORT
Quarter Ending March 31, 2026**

Type of Investment	Beginning Cost	Wilmington Interest	LOGIC Interest	Interfund Transfers/ Contributions	Disbursements	Ending Cost	Market Value
Local Govt. Investment Pool:							
Contingency: #2731494001	12,416,482	-	108,397	(1,154,248)	-	11,370,631	11,368,538
Road Maintenance: #2731494002	1,179,635	-	11,144	-	-	1,190,779	1,190,560
Total Local Govt. Investment Pool	\$ 13,596,117	\$ -	\$ 119,541	\$ (1,154,248)	\$ -	\$ 12,561,410	\$ 12,559,098
Government Securities (Federated Govt Obligations):							
General FD #154037-003 & #7731494007	\$ 1,321,533	\$ 3	\$ 12,481	\$ -	\$ -	\$ 1,334,017	1,333,772
Debt Service Fund 2020: #143255-001	475,337	5,230	-	991,488	-	1,472,055	1,472,055
Debt Service Account #154037-001	1,647,950	12,399	-	326,418	-	1,986,767	
Debt Service Account #154038-000	1,031	8	-	-	-	1,039	1,039
Debt Service Account #154038-001	28,489	3,803	-	1,452,830	-	1,485,122	1,485,122
DSRF Account #154037-002 & #7731494006	14,296,474	3	135,055	-	-	14,431,532	14,428,877
DSRF Account #154038-002 & #7731494005	6,447,793	3	60,908	-	-	6,508,704	6,507,506
Disbursement Account: #106912-006 & #7731494008	65,208,357	4,790	594,202	1,667,271	(6,785,507)	60,689,113	60,677,946
Total Government Securities	\$ 89,426,964	\$ 26,239	\$ 802,646	\$ 4,438,007	\$ (6,785,507)	\$ 87,908,349	\$ 85,906,316
Combined Totals	\$ 103,023,081	\$ 26,239	\$ 922,187	\$ 3,283,759	\$ (6,785,507)	\$ 100,469,759	\$ 98,465,415

*Note-Logic interest earned on HCRMA's funds held by Trustee (Wilmington Trust)

**Wilmington Trust Investments Detail Activity
Quarter Ending March 31, 2026**

HIDALGO CO RMA 2020 DS FUND #143255-001

		Income				Disbursements	Ending Balance
		Wilmington Interest	LOGIC Interest	Contributions	Interfund Transfers		
Debt Svc.:	Opening balance:						
January	475,337	886	-	-	330,496	-	806,719
February	806,719	1,715	-	-	330,496	-	1,138,930
March	1,138,930	2,629	-	-	330,496	-	1,472,055
		<u>5,230</u>	<u>-</u>	<u>-</u>	<u>991,488</u>	<u>-</u>	

CONTINGENCY ACCOUNT-LOGIC #2731494001

		Income				Disbursements	Ending Balance
		Wilmington Interest	LOGIC Interest	Contributions	Interfund Transfers		
Contingency:	Opening balance:						
January	12,416,482	-	40,355	-	(1,779,248)	-	10,677,589
February	10,677,589	-	31,937	425,000	-	-	11,134,526
March	11,134,526	-	36,105	200,000	-	-	11,370,631
		<u>-</u>	<u>108,397</u>	<u>625,000</u>	<u>(1,779,248)</u>	<u>-</u>	

ROAD MAINTENANCE ACCOUNT-LOGIC #2731494002

		Income				Disbursements	Ending Balance
		Wilmington Interest	LOGIC Interest	Contributions	Interfund Transfers		
Road Maint.:	Opening balance:						
January	1,179,635	-	3,869	-	-	-	1,183,504
February	1,183,504	-	3,457	-	-	-	1,186,961
March	1,186,961	-	3,818	-	-	-	1,190,779
		<u>-</u>	<u>11,144</u>	<u>-</u>	<u>-</u>	<u>-</u>	

HIDALGO CO RMA DISBURSEMENT ACCT #106912-006 & LOGIC #7731494008

		Income				Disbursements	Ending Balance
		Wilmington Interest	LOGIC Interest	Contributions	Interfund Transfers		
Disbursement:	Opening balance:						
January	65,208,357	1,250	209,854	-	-	(1,356,675)	64,062,786
February	64,062,786	1,202	185,434	1,078,246	-	(2,873,483)	62,454,185
March	62,454,185	2,338	198,914	589,025	-	(2,555,349)	60,689,113
		<u>4,790</u>	<u>594,202</u>	<u>1,667,271</u>	<u>-</u>	<u>(6,785,507)</u>	

HCRMA SR LIEN 2022A DS ACCT. #154037-001

		Income				Disbursements	Ending Balance
		Wilmington Interest	LOGIC Interest	Contributions	Interfund Transfers		
DS Account:	Opening balance:						
January	1,647,950	2,696	-	-	326,418	-	1,977,064
February	1,977,064	4,690	-	-	-	-	1,981,754
March	1,981,754	5,013	-	-	-	-	1,986,767
		<u>12,399</u>	<u>-</u>	<u>-</u>	<u>326,418</u>	<u>-</u>	

**Wilmington Trust Investments Detail Activity
Quarter Ending March 31, 2026**

HCRMA SR LIEN 2022A DSRF #154037-002 & LOGIC #7731494006

DSRF Account:	Opening balance:	Income		Contributions	Interfund Transfers	Disbursements	Ending Balance
		Wilmington Interest	LOGIC Interest				
January	14,296,474	1	46,896	-	-	-	14,343,371
February	14,343,371	1	41,890	-	-	-	14,385,262
March	14,385,262	1	46,269	-	-	-	14,431,532
		<u>3</u>	<u>135,055</u>	<u>-</u>	<u>-</u>	<u>-</u>	

HCRMA JR LIEN 2022B DS ACCT #154038-001

DS Account:	Opening balance:	Income		Contributions	Interfund Transfers	Disbursements	Ending Balance
		Wilmington Interest	LOGIC Interest				
January	28,489	83	-	-	1,452,830	-	1,481,402
February	1,481,402	81	-	-	-	-	1,481,483
March	1,481,483	3,639	-	-	-	-	1,485,122
		<u>3,803</u>	<u>-</u>	<u>-</u>	<u>1,452,830</u>	<u>-</u>	

HCRMA JR LIEN 2022B DSRF #154038-002 & LOGIC #7731494005

DSRF Account:	Opening balance:	Income		Contributions	Interfund Transfers	Disbursements	Ending Balance
		Wilmington Interest	LOGIC Interest				
January	6,447,793	1	21,149	-	-	-	6,468,943
February	6,468,943	1	18,892	-	-	-	6,487,836
March	6,487,836	1	20,867	-	-	-	6,508,704
		<u>3</u>	<u>60,908</u>	<u>-</u>	<u>-</u>	<u>-</u>	

HCRMA JR LIEN REV BDS 2022B #154038-000

Rev Bds 2022B	Opening balance:	Income		Contributions	Interfund Transfers	Disbursements	Ending Balance
		Wilmington Interest	LOGIC Interest				
January	1,031	3	-	-	-	-	1,034
February	1,034	3	-	-	-	-	1,037
March	1,037	2	-	-	-	-	1,039
		<u>8</u>	<u>-</u>	<u>-</u>	<u>-</u>	<u>-</u>	

HCRMA SR LIEN 2022A GENERAL FD #154037-003 & LOGIC #7731494007

General FD Account	Opening balance:	Income		Contributions	Interfund Transfers	Disbursements	Ending Balance
		Wilmington Interest	LOGIC Interest				
January	1,321,533	1	4,333	-	-	-	1,325,867
February	1,325,867	1	3,872	-	-	-	1,329,740
March	1,329,740	1	4,276	-	-	-	1,334,017
		<u>3</u>	<u>12,481</u>	<u>-</u>	<u>-</u>	<u>-</u>	

This Page
Intentionally
Left Blank

Item 3E

HIDALGO COUNTY REGIONAL MOBILITY AUTHORITY

AGENDA RECOMMENDATION FORM

BOARD OF DIRECTORS	<u> X </u>	AGENDA ITEM	<u> 3E </u>
PLANNING COMMITTEE	<u> </u>	DATE SUBMITTED	<u> 4/20/2026 </u>
FINANCE COMMITTEE	<u> </u>	MEETING DATE	<u> 04/28/2026 </u>
TECHNICAL COMMITTEE	<u> </u>		

1. Agenda Item: **RESOLUTION 2026-45 – APPROVAL OF THE HIDALGO COUNTY REGIONAL MOBILITY AUTHORITY DESIGNEE, ALTERNATE AND PROXY TO THE RIO GRANDE VALLEY METROPOLITAN PLANNING ORGANIZATION.**

2. Nature of Request: (Brief Overview) Attachments: X Yes No
Approval and Consideration of Resolution 2026-45 – Approval of HCRMA Designee, Alternate and Proxy to the HCMPO.

3. Policy Implication: Board Policy, Local Government Code, Texas Government Code, Texas Transportation Code, TxDOT Policy

4. Budgeted: Yes No X N/A

5. Staff Recommendation: **Resolution 2026- 45 – Approval of the Hidalgo County Regional Mobility Authority Designee, Alternate and Proxy to the Hidalgo County Metropolitan Planning Organization, as presented.**

6. Planning Committee’s Recommendation: Approved Disapproved X None

7. Board Attorney’s Recommendation: X Approved Disapproved None

8. Chief Auditor’s Recommendation: Approved Disapproved X None

9. Chief Financial Officer’s Recommendation: Approved Disapproved X None

10. Chief Development Engineer’s Recommendation: Approved Disapproved X None

11. Chief Construction Engineer’s Recommendation: Approved Disapproved X None

12. Executive Director’s Recommendation: X Approved Disapproved None

HIDALGO COUNTY REGIONAL MOBILITY AUTHORITY
BOARD RESOLUTION 2026- 45

**APPROVING DESIGNATION OF RIO GRANDE VALLEY
METROPOLITAN PLANNING ORGANIZATION MEMBERS FOR
THE HIDALGO COUNTY REGIONAL MOBILITY AUTHORITY**

THIS RESOLUTION is adopted this 28th day of April 2026 by the Board of Directors of the Hidalgo County Regional Mobility Authority.

WHEREAS, the Hidalgo County Regional Mobility Authority (the “Authority”), acting through its Board of Directors (the “Board”), is a regional mobility authority created pursuant to Chapter 370, Texas Transportation Code, as amended (the “Act”); and

WHEREAS, in accordance with the Rio Grande Valley Metropolitan Planning Organization Bylaws and Operating Procedures; the Chairman of the Hidalgo County Regional Mobility Authority serves as the defacto official member of the Metropolitan Planning Organization Policy Board; and

WHEREAS, the Rio Grande Valley Metropolitan Planning Organization Bylaws and Operating Procedures; further stipulate that one (1) Director of the Hidalgo County Regional Mobility Authority may be appointed to serve as alternate members of the Metropolitan Planning Organization Board of Directors.

NOW THEREFORE, BE IT RESOLVED, BY THE BOARD OF DIRECTORS OF THE HIDALGO COUNTY REGIONAL MOBILITY AUTHORITY THAT:

- Section 1. The recital clauses are incorporated in the text of this Resolution as if fully restated.
- Section 2. The Board of Directors hereby appoints Chairman, Robert L. Lozano, as the primary member of the Rio Grande Valley Metropolitan Planning Organization Policy Board.
- Section 3. The Board of Directors hereby appoints Vice Chairman, Juan Carlos Del Ángel, as the alternate member of the Rio Grande Valley Metropolitan Planning Organization Policy Board.
- Section 4. The Board of Directors hereby appoints Daneil Garcia, Executive Director, Ramon Navarro IV, Chief Construction Engineer, and Ruben Alfaro, Development Engineer, as designate proxies for the primary and alternate members with all appropriate privileges assigned.

* * *

PASSED AND APPROVED AS TO BE EFFECTIVE IMMEDIATELY BY THE BOARD OF DIRECTORS OF THE HIDALGO COUNTY REGIONAL MOBILITY AUTHORITY AT A REGULAR MEETING on the 28th day of April 2026, at which meeting a quorum was present.

Robert L. Lozano, Chairman

Michael J. Williamson, Secretary/Treasurer

Item 3F

HIDALGO COUNTY REGIONAL MOBILITY AUTHORITY

AGENDA RECOMMENDATION FORM

BOARD OF DIRECTORS	<u> X </u>	AGENDA ITEM	<u> 2F </u>
PLANNING COMMITTEE	<u> </u>	DATE SUBMITTED	<u> 04/20/26 </u>
FINANCE COMMITTEE	<u> </u>	MEETING DATE	<u> 04/28/26 </u>
TECHNICAL COMMITTEE	<u> </u>		

1. Agenda Item: **RESOLUTION 2026-47 – APPROVAL AND CONSIDERATION TO DESIGNATE JOSE CASTILLO AND DANIEL GARCIA AS INVESTMENT OFFICER FOR THE HIDALGO COUNTY REGIONAL MOBILITY AUTHORITY.**

2. Nature of Request: (Brief Overview) Attachments: Yes No
Approval and Consideration to designate Jose Castillo and Daniel Garcia as investment officers for the Hidalgo County Regional Mobility Authority.

3. Policy Implication: Board Policy, Local Government Code, Texas Government Code, Texas Transportation Code, TxDOT Policy

4. Budgeted: Yes No N/A

5. Staff Recommendation: **Motion to approve Resolution 2026-47 – Approval and Consideration to designate Jose Castillo and Daniel Garcia as investment officers for the Hidalgo County Regional Mobility Authority, as presented.**

6. Program Manager’s Recommendation: Approved Disapproved None

7. Planning Committee’s Recommendation: Approved Disapproved None

8. Board Attorney’s Recommendation: Approved Disapproved None

9. Chief Auditor’s Recommendation: Approved Disapproved None

10. Chief Financial Officer’s Recommendation: Approved Disapproved None

11. Chief Development Engineer’s Recommendation: Approved Disapproved None

12. Chief Construction Engineer’s Recommendation: Approved Disapproved None

13. Executive Director’s Recommendation: Approved Disapproved None



Memorandum

To: Robert L. Lozano, Chairman
From: Pilar Rodriguez, PE, Executive Director
Date: April 20, 2026
Re: **Resolution 2026-46 - Approval and Consideration to designate Jose Castillo and Daniel Garcia as investment officers for the Hidalgo County Regional Mobility Authority**

Background

The Executive Director and Chief Financial Officer serve as investment officers for the Hidalgo County Regional Mobility Authority. On April 21, 2026, Daniel Garcia was hired to be the Executive Director.

Goal

With the issuance of the Senior Lien Toll and Vehicle Registration fee Revenue Bonds, Series 2022A and Junior Lien Toll and Vehicle Registration Fee Revenue and Refunding Bonds, Series 2022B, it is necessary to invest the proceeds to minimize the cost for “warehousing” the funds. This would authorize the CFO and Executive Director to invest the bond proceeds in accordance with the HCRMA’s adopted Investment Policy.

Options

The Board of Directors may opt not to authorize staff to conduct investments on behalf of the Authority.

Recommendation

Based on review by this office, **approval of Resolution 2026-46 – Approval and Consideration to designate Jose Castillo and Daniel Garcia as investment officers for the Hidalgo County Regional Mobility Authority is recommended.**

If you should have any questions or require additional information, please advise.

HIDALGO COUNTY REGIONAL MOBILITY AUTHORITY
BOARD RESOLUTION NO. 2026-46

APPROVAL AND CONSIDERATION TO DESIGNATE JOSE CASTILLO AND DANIEL
GARCIA AS INVESTMENT OFFICERS FOR THE HIDALGO COUNTY REGIONAL
MOBILITY AUTHORITY

THIS RESOLUTION is adopted this 28th day of April, 2026 by the Board of Director of the Hidalgo County Regional Mobility Authority.

WHEREAS, the Hidalgo County Regional Mobility Authority (the “Authority”), acting through its Board of Directors (the “Board”); is a regional mobility authority created pursuant to Chapter 370, Texas Transportation Code, as amended (the “Act”); and

WHEREAS, the Board of Directors of the Authority has been constituted in accordance with the Act; and

WHEREAS, the prudent and legally permissible management and investment of Authority funds is responsibility of the Board of Directors and its designees; and

WHEREAS, the Authority initially adopted the Investment Policy at a regularly scheduled meeting on April 10, 2008; and

WHEREAS, the Authority reviews the Investment Policy every year at a regularly scheduled meeting; and

WHEREAS, the Investment Policy requires that the Board approve the designation of the Authority’s Investment Officers;

NOW, THEREFORE, BE IT RESOLVED BY THE BOARD OF DIRECTOR OF THE HIDALGO COUNTY REGIONAL MOBILITY AUTHORITY THAT:

- Section 1. The recital clauses are incorporated in the text of this Resolution as if fully restated.
- Section 2. The Board authorizes designation of Jose Castillo and Daniel Garcia to serve as the Investment Officers pursuant to the Investment Policy, such a person to be trained by the State of Texas and otherwise meeting the qualifications of an Investment Officer.
- Section 3. The Board approves the oversight of the Investment Officers and the Authority’s Financial Advisor.
- Section 4. The Board agrees to revisit the Investment Policy on an annual basis to ensure that such policy continues to meet statutory requirements and the needs of the Authority.

PASSED AND APPROVED AS TO BE EFFECTIVE IMMEDIATELY BY THE BOARD OF DIRECTORS OF THE HIDALGO COUNTY REGIONAL MOBILITY AUTHORITY AT A REGULAR MEETING on the 28th day of April, 2026, at which meeting a quorum was present.

Robert L. Lozano, Chairman

Attest:

Michael J. Williamson, Secretary/Treasurer

This Page
Intentionally
Left Blank

Item 3G

HIDALGO COUNTY REGIONAL MOBILITY AUTHORITY

AGENDA RECOMMENDATION FORM

BOARD OF DIRECTORS	<u> X </u>	AGENDA ITEM	<u> 3G </u>
PLANNING COMMITTEE	<u> </u>	DATE SUBMITTED	<u> 04/20/26 </u>
FINANCE COMMITTEE	<u> </u>	MEETING DATE	<u> 04/28/26 </u>
TECHNICAL COMMITTEE	<u> </u>		

1. Agenda Item: **RESOLUTION 2026-47 – AUTHORIZATION TO REMOVE PILAR RODRIGUEZ AS A SIGNATORY AND THE ADDITION OF DANIEL GARCIA AS AN AUTHORIZED SIGNATORY ON PLAINSCAPITAL BANK, TEXSTAR, LOGIC, HILLTOP SECURITIES, AND WILMINGTON TRUST ACCOUNTS.**

2. Nature of Request: (Brief Overview) Attachments: X Yes No

Approval and Consideration to remove Pilar Rodriguez as a signatory and the addition of Daniel Garcia as an authorized signatory on all PlainsCapital Bank, TexStar, Logic, Hilltop Securities, and Wilmington Trust accounts.

3. Policy Implication: Board Policy, Local Government Code, Texas Government Code, Texas Transportation Code, TxDOT Policy

4. Budgeted: Yes No X N/A

5. Staff Recommendation: **Motion to approve Resolution 2026-47 – Approval and Consideration to remove Pilar Rodriguez as a signatory and the addition of Daniel Garcia as an authorized signatory on all PlainsCapital Bank, TexStar, Logic, Hilltop Securities, and Wilmington Trust accounts, as presented.**

6. Program Manager’s Recommendation: Approved Disapproved X None

7. Planning Committee’s Recommendation: Approved Disapproved X None

8. Board Attorney’s Recommendation: Approved Disapproved X None

9. Chief Auditor’s Recommendation: X Approved Disapproved None

10. Chief Financial Officer’s Recommendation: Approved Disapproved X None

11. Chief Development Engineer’s Recommendation: Approved Disapproved X None

12. Chief Construction Engineer’s Recommendation: Approved Disapproved X None

13. Executive Director’s Recommendation: X Approved Disapproved None



Memorandum

To: Robert L. Lozano, Chairman

From: Pilar Rodriguez, PE, Executive Director

Date: April 20, 2026

Re: **Resolution 2026-47 – Approval and Consideration to remove Pilar Rodriguez as a signatory and the addition of Daniel Garcia as an authorized signatory on all PlainsCapital Bank, TexStar, Logic, Hilltop Securities, and Wilmington Trust accounts**

Background

The Hidalgo County Regional Mobility Authority (HCRMA) has historically held excess idle cash in its non-interest bearing demand account at the PlainsCapital. The Board Chairman, as well as the Chief Financial Officer and Executive Director are authorized signatories on the PlainsCapital Bank account. In addition, the Executive Director and Chief Financial Officer are authorized signatories on TexSTAR, Logic, Hilltop Securities, and Wilmington Trust accounts. Since Pilar Rodriguez will no longer be serving as the Executive Director for the HCRMA, removal as signatory on all PlainsCapital Bank, TexSTAR, Logic, Hilltop Securities, and Wilmington Trust accounts is warranted.

Goal

Staff is requesting authorization to add Daniel Garcia, HCRMA Executive Director, as an authorized signatory on all PlainsCapital Bank, TexSTAR, Logic, Hilltop Securities, and Wilmington Trust Accounts. The approval will allow executive staff to address daily transactions that are necessary as part of the management of the Authority's finances.

Options

The addition of signatories may be disapproved.

Recommendation

Based on review by this office, approval of **Resolution 2026-47 – Approval and Consideration to remove Pilar Rodriguez as a signatory and the addition of Daniel Garcia as an authorized signatory on all PlainsCapital Bank, TexStar, Logic, Hilltop Securites and Wilmington Trust accounts, is recommended.**

If you should have any questions or require additional information, please advise.

HIDALGO COUNTY REGIONAL MOBILITY AUTHORITY
BOARD RESOLUTION NO. 2026-47

APPROVAL AND CONSIDERATION TO REMOVE PILAR RODRIGUEZ AS A
SIGNATORY AND THE ADDITION OF DANIEL GARCIA AS AN AUTHORIZED
SIGNATORY ON ALL PLAINSCAPITAL BANK, TEXSTAR, LOGIC, HILLTOP
SECURITIES, AND WILMINGTON TRUST ACCOUNTS

THIS RESOLUTION is adopted this 28th day of April, 2026 by the Board of Director of the Hidalgo County Regional Mobility Authority.

WHEREAS, the Hidalgo County Regional Mobility Authority (the “Authority”), acting through its Board of Directors (the “Board”); is a regional mobility authority created pursuant to Chapter 370, Texas Transportation Code, as amended (the “Act”); and

WHEREAS, the Authority was created by Order of Hidalgo County (the “County”) dated October 26, 2004; Petition of the County dated April 21, 2005; and a Minute Order of the Texas Transportation Commission (the “Commission”) dated November 17, 2005, pursuant to provisions under the Act the Authority; and

WHEREAS, the Authority has established a certain bank account with PlainsCapital Bank, TexSTAR, Logic, Hilltop Securities, and Wilmington Trust; and

WHEREAS, it has become necessary to revise the authorized signatories for the PlainsCapital, TexSTAR, Logic, Hilltop Securities, and Wilmington Trust accounts;

NOW, THEREFORE, BE IT RESOLVED BY THE BOARD OF DIRECTOR OF THE HIDALGO COUNTY REGIONAL MOBILITY AUTHORITY THAT:

Section 1. The recital clauses are incorporated in the text of this Resolution as if fully restated.

Section 2. The Board authorizes the removal of Pilar Rodriguez as an authorized signatory on all PlainsCapital Bank, TexSTAR, Logic, Hilltop Securities, and Wilmington Trust Accounts.

Section 3. The Board authorizes the addition of Daniel Garcia as a signatory on all PlainsCapital Bank, TexSTAR, Logic, Hilltop Securities, and Wilmington Trust Accounts.

PASSED AND APPROVED AS TO BE EFFECTIVE IMMEDIATELY BY THE BOARD OF DIRECTORS OF THE HIDALGO COUNTY REGIONAL MOBILITY AUTHORITY AT A REGULAR MEETING on the 28th day of April, 2026, at which meeting a quorum was present.

Robert L. Lozano, Chairman

Attest:

Michael J. Williamson, Secretary/Treasurer

This Page
Intentionally
Left Blank

Item 4A

HIDALGO COUNTY REGIONAL MOBILITY AUTHORITY

AGENDA RECOMMENDATION FORM

BOARD OF DIRECTORS	<u> X </u>	AGENDA ITEM	<u> 4A </u>
PLANNING COMMITTEE	<u> </u>	DATE SUBMITTED	<u> 04/20/26 </u>
FINANCE COMMITTEE	<u> </u>	MEETING DATE	<u> 04/28/26 </u>
TECHNICAL COMMITTEE	<u> </u>		

1. Agenda Item: **RESOLUTION 2026-29 – APPROVAL OF FISCAL YEAR 2025 FINANCIAL STATEMENT AND INDEPENDENT AUDITORS REPORT FOR THE HIDALGO COUNTY REGIONAL MOBILITY AUTHORITY.**

2. Nature of Request: (Brief Overview) Attachments: X Yes No

Consideration and approval of Financial Statement and Independent Auditors Report prepared by Burton McCumber & Longoria, LLP for Fiscal Year 2025. The report is required by Texas Administrative Code Title 43, Part I, Chapter 26, Subchapter G §26.65(a) Annual Reports to the Commission.

3. Policy Implication: Board Policy, Local Government Code, Texas Government Code, Texas Transportation Code, TxDOT Policy

4. Budgeted: Yes No X N/A

5. Staff Recommendation: **Motion to approve Resolution 2026-29 – Approval of Fiscal Year 2025 Financial Statement and Independent Auditors Report, as presented.**

6. Program Manager’s Recommendation: Approved Disapproved X None

7. Planning Committee’s Recommendation: Approved Disapproved X None

8. Board Attorney’s Recommendation: Approved Disapproved X None

9. Chief Auditor’s Recommendation: Approved Disapproved X None

10. Chief Financial Officer’s Recommendation: X Approved Disapproved None

11. Development Engineer’s Recommendation: Approved Disapproved X None

12. Construction Engineer’s Recommendation: Approved Disapproved X None

13. Executive Director’s Recommendation: X Approved Disapproved None



Memorandum

To: Robert L. Lozano, Chairman
From: Pilar Rodriguez, PE, Executive Director
Date: April 20, 2026
Re: **Approval of Fiscal Year 2025 Financial Statement and Independent Auditors Report**

Background

Texas Administrative Code Title 43, Part I, Chapter 26, Subchapter G §26.65(a) requires annual reports to the Texas Transportation Commission, which includes audited financial statements of the Authority's books and records.

Goal

In order to comply with the Texas Administrative Code Requirement, the Board of Director must review and accept the Independent Auditor's Report.

A copy of the Financial Statement and Independent Auditor's Report prepared by Burton McCumber & Longoria is attached for your review and consideration.

Options

The Board of Directors could opt not to accept the Independent Auditor's Report.

Recommendation

Based on review by this office, approval of Resolution 2026-29 – Approval of the Fiscal Year 2025 Financial Statement and Independent Auditor's Report is recommended.

If you should have any questions or require additional information, please advise.

HIDALGO COUNTY REGIONAL MOBILITY AUTHORITY
BOARD RESOLUTION NO. 2026-29

APPROVAL OF FISCAL YEAR 2025 FINANCIAL STATEMENT AND INDEPENDENT
AUDITORS REPORT

THIS RESOLUTION is adopted this 28th day of April, 2026, by the Board of Director of the Hidalgo County Regional Mobility Authority.

WHEREAS, the Hidalgo County Regional Mobility Authority (the “Authority”), acting through its Board of Directors (the “Board”); is a regional mobility authority created pursuant to Chapter 370, Texas Transportation Code, as amended (the “Act”); and

WHEREAS, the Authority was created by Order of Hidalgo County (the “County”) dated October 26, 2004; Petition of the County dated April 21, 2005; and a Minute Order of the Texas Transportation Commission (the “Commission”) dated November 17, 2005, pursuant to provisions under the Act the Authority; and

WHEREAS, the Authority is required to report to the Texas Department of Transportation the annual financial statement and independent auditors report pursuant to the Texas Administrative Code, Title 43, Part 1, Chapter 26, Subchapter G (Regional Mobility Authority Reports and Audits), as amended; and

WHEREAS, the Authority’s 2025 fiscal year commenced on January 1, 2025 and ended on December 31, 2025; and

WHEREAS, the Board accepts the Fiscal Year 2025 Financial Statement and Independent Auditors Report prepared by Burton McCumber & Longoria, LLP;

NOW, THEREFORE, BE IT RESOLVED BY THE BOARD OF DIRECTOR OF THE
HIDALGO COUNTY REGIONAL MOBILITY AUTHORITY THAT:

- Section 1. The recital clauses are incorporated in the text of this Resolution as if fully restated.
- Section 2. The Board accepts the Fiscal Year 2025 Financial Statement and Independent Auditors Report, hereto attached as Exhibit A.

Passed and Approved as to be effective immediately this 28th day of April, 2026, at a regular meeting of the Board of Directors of the Hidalgo County Regional Mobility Authority at which a quorum was present and which was held in accordance with the provisions of Chapter 551, Texas Government Code.

Robert L. Lozano, Chairman

Attest:

Michael J. Williamson, Secretary/Treasurer

EXHIBIT A
FINANCIAL STATEMENT AND INDEPENDENT AUDITORS REPORT
FOR
FISCAL YEAR 2025

Item 4B

HIDALGO COUNTY REGIONAL MOBILITY AUTHORITY

AGENDA RECOMMENDATION FORM

BOARD OF DIRECTORS	<u> X </u>	AGENDA ITEM	<u> 4B </u>
PLANNING COMMITTEE	<u> </u>	DATE SUBMITTED	<u> 04/20/26 </u>
FINANCE COMMITTEE	<u> </u>	MEETING DATE	<u> 04/28/26 </u>
TECHNICAL COMMITTEE	<u> </u>		

1. Agenda Item: **RESOLUTION 2026-30 – APPROVAL OF 2025 ANNUAL COMPLIANCE REPORT FOR THE HIDALGO COUNTY REGIONAL MOBILITY AUTHORITY.**

2. Nature of Request: (Brief Overview) Attachments: X Yes No
Consideration and approval of Annual Compliance Report to the Texas Department for the Fiscal Year 2025.

3. Policy Implication: Board Policy, Local Government Code, Texas Government Code, Texas Transportation Code, TxDOT Policy

4. Budgeted: Yes No X N/A

5. Staff Recommendation: **Motion to approve Resolution 2026-30 – Approval of the 2025 Annual Compliance Report for the Hidalgo County Regional Mobility Authority as presented.**

6. Program Manager’s Recommendation: X Approved Disapproved None

7. Planning Committee’s Recommendation: Approved Disapproved X None

8. Board Attorney’s Recommendation: Approved Disapproved X None

9. Chief Auditor’s Recommendation: X Approved Disapproved None

10. Chief Financial Officer’s Recommendation: X Approved Disapproved None

11. Development Engineer’s Recommendation: Approved Disapproved X None

12. Construction Engineer’s Recommendation: Approved Disapproved X None

13. Executive Director’s Recommendation: X Approved Disapproved None



Memorandum

To: Robert L. Lozano, Chairman
From: Pilar Rodriguez, PE, Executive Director
Date: April 20, 2026
Re: **Approval of 2025 Compliance Report to the Texas Department of Transportation**

Background

The compliance report is required under the Texas Administrative Code, Title 43, Part 1, Chapter 26, Subchapter G (Regional Mobility Authority Reports and Audits), as amended.

Goal

In order to comply with the Texas Administrative Code Requirement, the Board of Director must review and accept the Compliance Report.

A copy of the 2025 Compliance Report is attached for your review and consideration.

Options

The Board of Directors could opt not to accept the Compliance Report.

Recommendation

Based on review by this office, **approval of Resolution 2026-30 – Approval of 2025 Compliance Report for the Hidalgo County Regional Mobility Authority is recommended.**

If you should have any questions or require additional information, please advise.

HIDALGO COUNTY REGIONAL MOBILITY AUTHORITY
BOARD RESOLUTION NO. 2026-30

RESOLUTION APPROVING 2025 ANNUAL COMPLIANCE REPORT

THIS RESOLUTION is adopted this 28th day of April, 2026, by the Board of Director of the Hidalgo County Regional Mobility Authority.

WHEREAS, the Hidalgo County Regional Mobility Authority (the “Authority”), acting through its Board of Directors (the “Board”); is a regional mobility authority created pursuant to Chapter 370, Texas Transportation Code, as amended (the “Act”); and

WHEREAS, the Authority was created by Order of Hidalgo County (the “County”) dated October 26, 2004; Petition of the County dated April 21, 2005; and a Minute Order of the Texas Transportation Commission (the “Commission”) dated November 17, 2005, pursuant to provisions under the Act the Authority; and

WHEREAS, the Authority is required to submit to the Texas Department of Transportation the annual compliance report pursuant to the Texas Administrative Code, Title 43, Part 1, Chapter 26, Subchapter G (Regional Mobility Authority Reports and Audits), as amended; and

WHEREAS, the Authority’s 2025 fiscal year commences on January 1, 2025 and ended on December 31, 2025; and

WHEREAS, the Authority has reviewed the annual compliance report for Fiscal Year 2025;

NOW, THEREFORE, BE IT RESOLVED BY THE BOARD OF DIRECTORS OF THE HIDALGO COUNTY REGIONAL MOBILITY AUTHORITY THAT:

- Section 1. The recital clauses are incorporated in the text of this Resolution as if fully restated.
- Section 2. The Board approves the annual compliance report for Fiscal Year 2025, hereto attached as Exhibit A.
- Section 3. The Board of Directors authorize the Executive Director to submit the 2025 annual compliance report to the Texas Department of Transportation.

Passed and Approved as to be effective immediately this 28th day of April, 2026, at a regular meeting of the Board of Directors of the Hidalgo County Regional Mobility Authority at which a quorum was present and which was held in accordance with the provisions of Chapter 551, Texas Government Code.

Robert L. Lozano, Chairman

Attest:

Michael J. Williamson, Secretary/Treasurer

EXHIBIT A

HIDALGO COUNTY REGIONAL MOBILITY AUTHORITY
FISCAL YEAR 2025 COMPLIANCE REPORT

Hidalgo County Regional Mobility Authority Compliance Report

Texas Administrative Code Title 43, Part I, Chapter 26, Subchapter G
§26.65(a) Annual Reports to the Commission

Compliance Rule	Compliance Statement	Certification
<i>Rule §26.61 Written Reports:</i>		
The annual operating and capital budgets adopted by the RMA year.	HCRMA is in compliance.	HCRMA adopted the FY 2026 Operating & Capital Budget on December 16, 2025.
Any annual financial information and notices of material events required to be disclosed under Rule 15c2-12 of the SEC.	Not applicable.	
To the extent not disclosed in another report required in this compliance report, a statement of any surplus revenue held by the RMA and a summary of how it intends to use the surplus revenue.	Not applicable. HCRMA does not have surplus revenue at this time.	
An independent auditor's review of the reports of investment transactions prepared under Government Code, §2256.023.	HCRMA is in compliance.	HCRMA Board of Directors accepted the FY 2025 financial statement and independent audit on April 28, 2026, which included a review of investment transactions.
<i>Rule §26.62 Annual Audit:</i>		
The RMA shall maintain its books and records in accordance with generally accepted accounting principles in the United States and shall have an annual financial and compliance audit of such books and records.	HCRMA is in compliance.	HCRMA Board of Directors accepted the FY 2025 financial statement and independent audit on April 28, 2026.
The annual audit shall be submitted to each county or city that is a part of the RMA within 120 days after the end of the fiscal year, and conducted by an independent certified public accountant.	HCRMA is in compliance.	HCRMA has made the financial statement and independent auditors report available to all interested parties.
All work papers and reports shall be retained for a minimum of four years from the date of the audit.	HCRMA is in compliance.	HCRMA's record retention policy in compliance with this requirement.
<i>Rule §26.63 Other Reports to Counties and Cities:</i>		
Provide other reports and information regarding its activities promptly when requested by the counties or cities.	HCRMA is in compliance.	All reports and activities are posted on the HCRMA web site at www.hcrma.net .
<i>Rule §26.64 Operating Records:</i>		
The Department will have access to all operating and financial records of the RMA. The executive director will provide notification if access is desired by the department.	HCRMA is in compliance.	

This Page
Intentionally
Left Blank

Item 4C

HIDALGO COUNTY REGIONAL MOBILITY AUTHORITY

AGENDA RECOMMENDATION FORM

BOARD OF DIRECTORS	<u> X </u>	AGENDA ITEM	<u> 4C </u>
PLANNING COMMITTEE	<u> </u>	DATE SUBMITTED	<u> 4/21/2026 </u>
FINANCE COMMITTEE	<u> </u>	MEETING DATE	<u> 4/28/2026 </u>
TECHNICAL COMMITTEE	<u> </u>		

1. Agenda Item: **RESOLUTION 2026-32 – CONSIDERATION AND AUTHORIZATION TO REIMBURSE THE TEXAS DEPARTMENT OF TRANSPORTATION (TX DOT) FOR SURVEY WORK FOR THE SH 68/FM 3072/SPUR 81 (IBTC) PROJECT TO ALLOW FOR TRANSFER OF RIGHT OF WAYS TO TX DOT FROM THE HIDALGO COUNTY REGIONAL MOBILITY AUTHORITY.**

2. Nature of Request: (Brief Overview) Attachments: X Yes No
Approval of Resolution 2026-32 to reimbursement the TxDOT for survey work for SH 68/FM 3072/Spur 81 (IBTC) Project.

3. Policy Implication: Board Policy, Local Government Code, Texas Government Code, Texas Transportation Code, TxDOT Policy

4. Budgeted: Yes No X N/A

5. Staff Recommendation: **Motion to approve Resolution 2026-32 – Consideration and authorization to reimburse the Texas Department of Transportation (Tx DOT) for survey work for the SH 68/FM 3072/Spur 81 (IBTC) Project to allow for transfer of right of ways to TxDOT from the Hidalgo County Regional Mobility Authority, as presented.**

6. Program Manager’s Recommendation: Approved Disapproved X None

7. Planning Committee’s Recommendation: Approved Disapproved X None

8. Board Attorney’s Recommendation: Approved Disapproved X None

9. Chief Auditor’s Recommendation: Approved Disapproved X None

10. Chief Financial Officer’s Recommendation: Approved Disapproved X None

10. Chief Development Engineer’s Recommendation: Approved Disapproved X None

11. Chief Construction Engineer’s Recommendation: X Approved Disapproved X None

12. Executive Director’s Recommendation: X Approved Disapproved None



Memorandum

To: Pilar Rodriguez, P.E
HCRMA, Executive Director

From: Ramon Navarro, IV, P.E., C.F.M.
HCRMA, Chief Construction Engineer

Date: April 21, 2026

Subject: **RESOLUTION 2026-32 – CONSIDERATION AND AUTHORIZATION TO REIMBURSE THE TEXAS DEPARTMENT OF TRANSPORTATION (TXDOT) FOR SURVEY WORK FOR THE SH 68/FM 3072/SPUR 81 (IBTC) PROJECT TO ALLOW FOR TRANSFER OF RIGHT OF WAYS TO TXDOT FROM THE HIDALGO COUNTY REGIONAL MOBILITY AUTHORITY.**

GOAL

Authorize required surveying services for transfer of IBTC ROW

CONSIDERATION

TxDOT has requested additional survey work to delineate and formally document ROW parcels within the corridor. These surveys will produce metes-and-bounds descriptions and parcel exhibits necessary for inclusion in the final deed instruments conveying property to the State .

The total estimated cost for these services is approximately \$73,410.54, based on a proposal from TxDOT’s contracted surveyor, McKim & Creed, Inc. . This cost is considered a participating contribution by HCRMA to advance the project and enable timely transfer of property interests.

Additionally, TxDOT has clarified that:

- The survey is required to separate donated parcels from remainder tracts, ensuring only
 - applicable ROW is conveyed, while residual property remains under HCRMA ownership
- Completion of this survey is a prerequisite for ROW transfer and project progression

Approval of this item will:

- Authorize reimbursement to TxDOT for survey services
- Enable preparation of final ROW exhibits and deeds
- Facilitate transfer of ROW to TxDOT for incorporation into the State Highway System
- Support continued advancement of the SH 68 (IBTC) project

RECOMMENDATION

Staff recommends approval of resolution.

HIDALGO COUNTY REGIONAL MOBILITY AUTHORITY BOARD
RESOLUTION No. 2026-32

CONSIDERATION AND AUTHORIZATION TO REIMBURSE THE TEXAS DEPARTMENT OF TRANSPORTATION (TXDOT) FOR SURVEY WORK FOR THE SH 68/FM 3072/SPUR 81 (IBTC) PROJECT TO ALLOW FOR TRANSFER OF RIGHT OF WAYS TO TXDOT FROM THE HIDALGO COUNTY REGIONAL MOBILITY AUTHORITY.

THIS RESOLUTION is adopted this 28th day of April, 2026, by the Board of Directors of the Hidalgo County Regional Mobility Authority.

WHEREAS, the Hidalgo County Regional Mobility Authority (the “Authority”), acting through its Board of Directors (the “Board”), is a regional mobility authority created pursuant to Chapter 370, Texas Transportation Code, as amended (the “Act”); and

WHEREAS, on November 17, 2005, the Texas Transportation Commission (the “Commission”) created the Authority pursuant to (i) the Act; (ii) Title 43, Texas Administrative Code; (iii) a petition of the Hidalgo County Commissioners Court (the “County”); and (iv) findings by the Commission that the creation of the Authority would result in certain direct benefits to the State of Texas (the “State”), local governments, and the traveling public and would improve the State’s transportation system; and

WHEREAS, the Authority is a political subdivision with the power of condemnation and the right to purchase surplus real property from the Texas Department of Transportation under Texas Transportation Code, Section 202.021; and

WHEREAS, on February 11, 2026, the Authority received notice letters from the Texas Department of Transportation for request for surveying services to produce a survey of all RMA owned properties within our SH 68 (Formally IBTC) project to delineate RMA owned ROW within the SH 68 corridor that will be included as an exhibit on the Deed that will be transfer said parcels to the State of Texas,

WHEREAS, the Authority finds it necessary to consider for approval Resolution 2026-32, for authorization of survey and deeds of parcels affiliated with all RMA owned properties within SH 68 (Formally IBTC) project to facilitate transfer of RMA owned ROW within the SH 68 corridor to the State of Texas,

NOW THEREFORE BE IT RESOLVED by the Board of Directors of the Hidalgo County Regional Mobility Authority that:

- Section 1. The recital clauses are incorporated in the text of this Resolution as if fully restated.
- Section 2. The Board finds this action serves a valid public purpose; and authorizes the donation and conveyance of ROW to TxDOT.
- Section 3. The Executive Director is authorized to execute all necessary documents, plus survey costs, and any additional fees, for the efficient transfer of ROW to TxDOT
- Section 4. This resolution shall serve as a written election statement of the Authority’s intent to convey and transfer the Properties.

PASSED AND APPROVED AS TO BE EFFECTIVE IMMEDIATELY BY THE BOARD OF DIRECTORS OF THE HIDALGO COUNTY REGIONAL MOBILITY AUTHORITY AT A REGULAR MEETING, duly posted and noticed, on the 28th day of April 2026, at which meeting a quorum was present.

Robert L. Lozano, Chairman

Micheal Williamson, Secretary/Treasurer

PARCEL #	FIRT NAME	LAST NAME	PARCEL SIZE (SQFT)	STRUCTURE (SQFT)	NOTES
T1	ALLEN W. & CYNTHIA K	COHRS	74,650.64	-	NO STRUCTURES
P238	TODD & MISHELLE	KING	52,711.71	-	NO STRUCTURES
P239	COHRS PROPERTIES, INC	COHRS	117,841.57	1350	1 STRUCTURE
P240	TROY P.	MCMLLAN	38,922.88	-	NO STRUCTURES
P241	F.J.	WESCHWETZ, JR.	214,504.29	-	NO STRUCTURES
P242	JOSE & JUDITH	TANGUMA	101,432.58	-	NO STRUCTURES
P243	MARIANO & ELVA	ESTRADA	32,847.20	-	NO STRUCTURES
P244	MIRIAM	HIDALGO	32,656.85	-	NO STRUCTURES

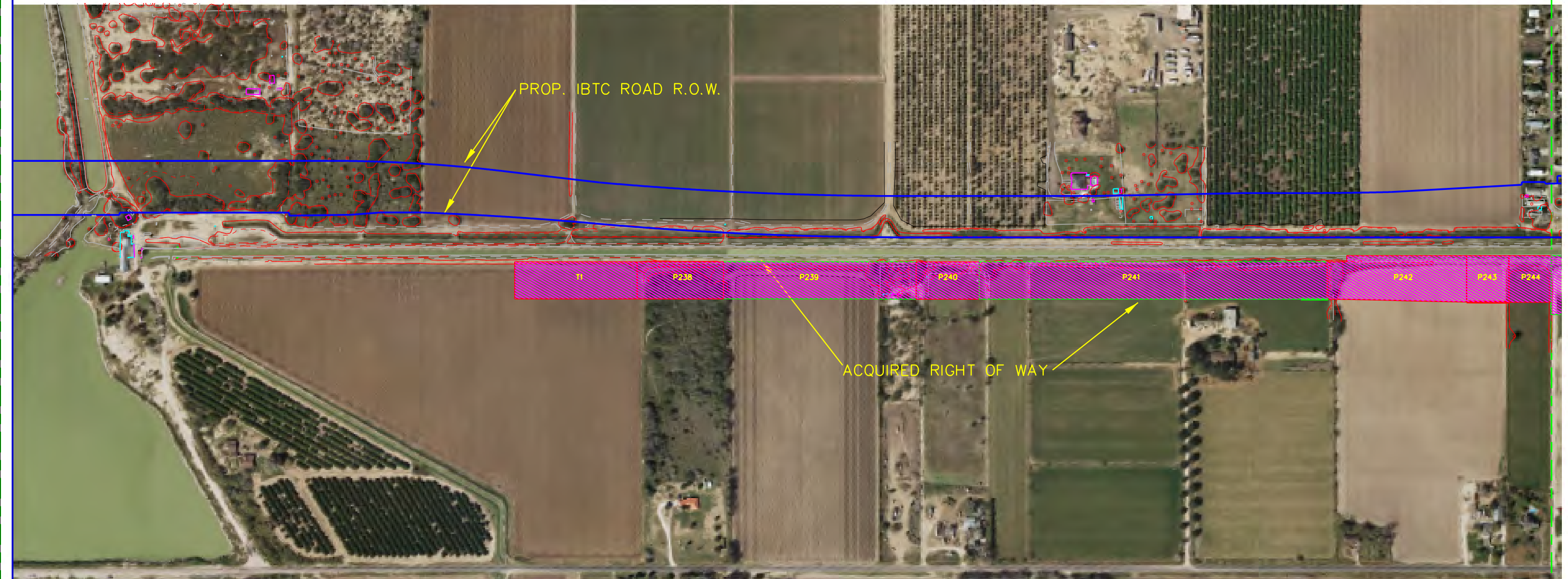
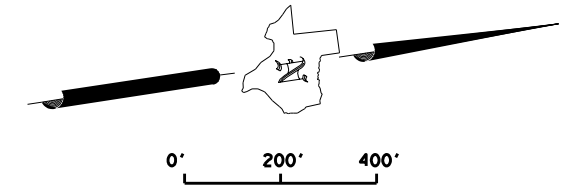

HCRMA
HIDALGO COUNTY REGIONAL MOBILITY AUTHORITY

Texas Department of Transportation

DANNENBAUM
ENGINEERING COMPANY - McALLEN, LLC
T.B.P.E. FIRM REGISTRATION #8999
1109 NOLANA LOOP, STE 200 McALLEN, TX 78504 (956) 662-3677

**INTERNATIONAL BRIDGE
TRADE CORRIDOR
HCRMA PROPOSED
RIGHT OF WAY**

DATE	REV	STATE	PROJECT NO.	SCALE
02/14/17	1	TX	0921	1"=200'
ENGINEER	DATE	CITY	COUNTY	JOB
PHR	02/14/17	MCALLEN	HIDALGO	0921
DESIGNER	DATE	CITY	COUNTY	JOB
PHR	02/14/17	MCALLEN	HIDALGO	0921
CHECKER	DATE	CITY	COUNTY	JOB
PHR	02/14/17	MCALLEN	HIDALGO	0921

ETT AFFECTED PARCELS

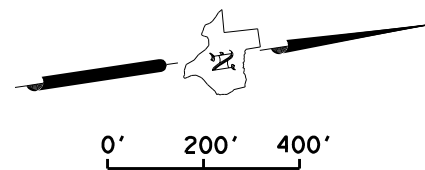

PARCEL #	FIRT NAME	LAST NAME	PARCEL SIZE (SQFT)	STRUCTURE SQFT	NOTES
T12/P262	QUITE VILLAGE II, ASSOCIATION IN TRUST		26,438.69	-	2 PARCELS-262 IS INSIDE OF T12 (RIGHT OF WAY TAKING)
T13	GEORGE L & CARMEN M	HOGAN	5,500.44	102.33 + 237.91 + 1284.21 + 146.73	4 STRUCTURES
T14	GARY L & VIRGINIA K	HUGHES	3,972.03	748.09 + 68.41 + 89.61	3 STRUCTURES
T15	DON H & SHERRY SCOTT	CLAYTON & SCOTT	1,800.14	150.46 + 645.1	2 STRUCTURES
T16	RUTH C	WORD	3,600.29	1019.47 + 249.29 + 114.49 + 67.88	4 STRUCTURES
T17	HELEN	WOOD	3,900.31	1503.65 + 8.21	2 STRUCTURES
T18	DAVID F. & CARROL	ZORN	2,040.16	89.27	1 STRUCTURE
T19	CAROL J.	BAKER	2,700.22	1665.15	1 STRUCTURE
T20	PATRICK J.	BAKER	2,700.22	558.08	1 STRUCTURE
T21	CURTIS S	BENTHAM	2,700.22	1296.4	1 STRUCTURE
T22	JOHN A.	CHALMERS, ET UX	3,071.96	150.45 + 1358.17	2 STRUCTURES
T23	JOHN & JOYCE M.	CURRY	5,500.44	662.6	1 STRUCTURE
T24/P261	T.L. & B.W.	GILLEN	2,392.84	344.29 (1 STRUCTURE)	TWO PARCELS CLOSED AS ONE (LOT & RIGHT OF WAY)
T100	DELAINO VICTOR & SUZANNE	SCHAFFER	4,000.32	529.61	1 STRUCTURE
T101	WARD & LEAH	CRUMLEY	4,020.32	597.92 + 57.97 + 64.7	3 STRUCTURES
T102	DON	CLAYTON	1,800.14	66.5 + 792.04 + 204.18	3 STRUCTURES
T103	ROSALINDA	WHIPPLE	1,800.14	237.38	1 STRUCTURE
T104	ROBERT & CAROL	PRATT	1,800.14	90.01	1 STRUCTURE
T105	ROBERT & CAROL	PRATT	1,800.14	1061.88	1 STRUCTURE
T106	CARL & PATRICIA	ERICKSON	2,100.17	717.52	1 STRUCTURE
T107	DELL	OSTERDYK	3,840.31	767.31 + 384.81	2 STRUCTURES
T108	JOHN W. & VIRGINIA W.	CLEMENS	4,500.32	74.41 + 1759.04	2 STRUCTURES
T109	JOHN W. & VIRGINIA W.	CLEMENS	4,920.43	2748.35	1 STRUCTURE
T110	THE SCHMEHR FAMILY LIVING TRST	SCHMEHR	4,000.32	589.55 + 103.99	2 STRUCTURES
P245	RUBEN & NOEMI R.	TRISTAN	35,106.84	-	NO STRUCTURES
P246	MARGO	KRAUSS	65,267.02	-	NO STRUCTURES
P247	DONNA IRRIGATION DISTRICT	-	12,143.67	-	NO STRUCTURES
P248A	MARK	AUSTIN	2,392.84	92.35 + 5.04	TWO STRUCTURES
P248B	MARK	AUSTIN	1,473.53	-	NO STRUCTURES
P249	LARRY & JANICE	CLINTON	2,947.06	1521.17	ONE STRUCTURE

PARCEL #	FIRT NAME	LAST NAME	PARCEL SIZE (SQFT)	STRUCTURE SQFT	NOTES
P250	ROLAND & GEORGETTE	FIOLA	1,473.53	166.78	ONE STRUCTURE
P251A	J.	JONES	1,473.53	-	NO STRUCTURE
P251B	EDWARD & MARY J	JONES	1,473.53	-	NO STRUCTURE
P252A	WILLIAM H & PATRICIA W	SHAWLEY REVOCABLE LT.	1,473.53	-	NO STRUCTURE
P252B	WILLIAM H & PATRICIA W	SHAWLEY REVOCABLE LT.	1,473.53	-	NO STRUCTURES
P253	ARMANDO & SUSAN	GALVAN	1,473.53	80.18 + 630.01	2 STRUCTURES
P254	NONA	KOWALESKI	1,473.53	89.31 + 257.83	2 STRUCTURES
P255	ROGER & CAROL	PRICE	1,473.53	159.23	1 STRUCTURE
P256	GLEN JOSEPH	SILLS	4,420.58	1952.551	1 STRUCTURE
P257	RODNEY D. & LINDA J.	CROUSE	1,473.53	990.24	1 STRUCTURE
P258A	GLEN J. BARBRA PARSON	SILLS	1,473.53	895.00	1 STRUCTURE
P258B	GLEN J. BARBRA PARSON	SILLS	1,473.53	82.49	1/2 STRUCTURE (HALF LOCATED ALSO ON 258C)
P258C	GLEN J. BARBRA PARSON	SILLS	1,473.53	SEE NOTE	1/2 STRUCTURE (HALF LOCATED ALSO ON 258B)
P259	EDWARD R. & MARY J.	JONES	2,947.06	79.22 + 47.64	2 STRUCTURES
P260	B.W. & T.L.	GILLEN	1,472.51	-	NO STRUCTURE
*P263	GEOVAL PROPERTIES, LLC	ELIZONDO	157,651.00	2984.56 + 3104.96 + 27.28 + 5.67 4.54 + 58.69	6 STRUCTURES
P264	ST. L.B. & M. RAILROAD	PERMIT	18,767.00	-	NO STRUCTURES; PERMIT ACQUIRED
*P265A	STEVEN J. & JANET K.	FILE	78,121	1129.11 + 956.43 + 1322.57 195.31 + 41.6 + 62.2 + 224.63 88.19 + 100.35 + 87.72 + 44.69 + 295.84 101.07 + 58.93 + 626.31 + 189.41 622.21 + 79.96 + 85.8 + 52.07 + 160.26 + 1042.32 + 404.59 682.95 + 85.19 + 1063.3 (PARTIALLY IN TAKING)	26 STRUCTURES
P265B	STEVEN J. & JANET K.	FILE	757	-	NO STRUCTURES
*P266	STEVEN J.	FILE	32,670.00	970.23 + 3275.8 (SEE NOTE)	1 FULL STRUCTURE, 1/2 STRUCTURE
*P267	H.P.	CRUMLEY	47,822.00	(SEE NOTE)	1/2 STRUCTURE LOCATED ON P266
*P268	RED-BEN, LLC	VELA/BENAVIDEZ	387,503.00	-	NO STRUCTURES
P268A	RED-BEN, LLC	VELA/BENAVIDEZ	66,211.00	-	NO STRUCTURES

ROADWAY PARCELS

PARCEL #	FIRT NAME	LAST NAME	PARCEL SIZE (SQFT)	STRUCTURE SQFT	NOTES
P271	SUSANA	IBARRA	8,385	2062.86	1 STRUCTURE
P272A	PELON LLC	ORTEGA	7,466	-	NO STRUCTURES
P272B	PELON LLC	ORTEGA	7,466	-	NO STRUCTURES
P272C	PELON LLC	ORTEGA	7,466	-	NO STRUCTURES
P272D	PELON LLC	ORTEGA	7,466	-	NO STRUCTURES
P272E	PELON LLC	ORTEGA	7,466	-	NO STRUCTURES
P273A	PELON LLC	ORTEGA	8,228	-	NO STRUCTURES
P273B	PELON LLC	ORTEGA	7,680	-	NO STRUCTURES
P273C	PELON LLC	ORTEGA	7,680	-	NO STRUCTURES
P273D	PELON LLC	ORTEGA	7,680	-	NO STRUCTURES
P273E	PELON LLC	ORTEGA	7,680	-	NO STRUCTURES
P273F	PELON LLC	ORTEGA	7,680	-	NO STRUCTURES
P273H	PELON LLC	ORTEGA	7,680	-	NO STRUCTURES
P273I	PELON LLC	ORTEGA	7,680	-	NO STRUCTURES
P273J	PELON LLC	ORTEGA	7,680	-	NO STRUCTURES
P273K	PELON LLC	ORTEGA	7,680	-	NO STRUCTURES
P273L	PELON LLC	ORTEGA	8,228	-	NO STRUCTURES
P275	PELON LLC	ORTEGA	8,228	-	NO STRUCTURES
P276	BRIAN A & FLORDELIZ V	CHEATHAM	7,680	1686.02	1 STRUCTURES
P277A	PELON LLC	ORTEGA	7,680	-	NO STRUCTURES
P277B	PELON LLC	ORTEGA	7,680	-	NO STRUCTURES
P277C	PELON LLC	ORTEGA	7,680	-	NO STRUCTURES
P277D	PELON LLC	ORTEGA	7,680	-	NO STRUCTURES
P278A	JESUS & DORA	ANDRADE	7,680	2214.84	1 STRUCTURES
P279	JUAN R & WENDY C	REYES	7,680	1849.50	1 STRUCTURES

PARCEL #	FIRT NAME	LAST NAME	PARCEL SIZE (SQFT)	STRUCTURE SQFT	NOTES
P280	EPIFANIO & LUCIA	MARTINEZ	8,228	1849.51	1 STRUCTURES
P281	JORGE L & MARIA E ANINA	SANTILLAN-LABASTIDA	8,228	1851.33	1 STRUCTURES
P282	PELON LLC	ORTEGA	7,200	-	NO STRUCTURES
P283A	HARLEY D & VANESSA SANCHEZ	LEDESMA	7,200	1179.97	1 STRUCTURES
P284A	JUAN J & SYLVIA ALANIZ	SIERRA	7,200	1901.59	1 STRUCTURES
P285	JAY & NINA	NEWBY	7,200	1878.17	1 STRUCTURES
P286	KLASSEN	RANDY	8,228	1958.44 + 32.67 + 193.36 + 250.07	4 STRUCTURES
P287	JOSE A & BRENDA	MERLA & NAVARRO	7,200	1672.29	1 STRUCTURE
P288	MARIA I & HECTOR E	VALDEZ	7,200	2202.51	1 STRUCTURE
P289	PELON LLC	ORTEGA	7,200	-	NO STRUCTURE
P290	RAUL & SANDRA	TAMEZ & PEREZ	7,200	2069.33	1 STRUCTURE
P291	GREEN TREE SERVICING, LLC	-	7,200	1655.08	1 STRUCTURE
P292	SERGIO M. & MARIBEL	CALDERA & OLIVO	7,200	1865.59	1 STRUCTURE
P293	JUAN C. & PATRICIA	RODRIGUEZ	7,200	2181.65	1 STRUCTURE
P294A	PELON LLC	ORTEGA	7,200	-	NO STRUCTURE
P294B	PELON LLC	ORTEGA	7,200	-	NO STRUCTURE
P294C	PELON LLC	ORTEGA	7,200	-	NO STRUCTURE
P295	MRSJ INVESTMENTS LLC	SALDIVAR	7,200	1889.55	1 STRUCTURE
P296A	PELON LLC	ORTEGA	7,200	-	NO STRUCTURE
P296B	PELON LLC	ORTEGA	7,200	-	NO STRUCTURE
P296C	PELON LLC	ORTEGA	7,200	-	NO STRUCTURE
P296D	PELON LLC	ORTEGA	7,200	-	NO STRUCTURE
P296E	PELON LLC	ORTEGA	7,200	-	NO STRUCTURE
P296F	PELON LLC	ORTEGA	7,687	-	NO STRUCTURE
T28	DAVID	GARCIA-MORENO	7,200.00	2078.06	1 STRUCTURE

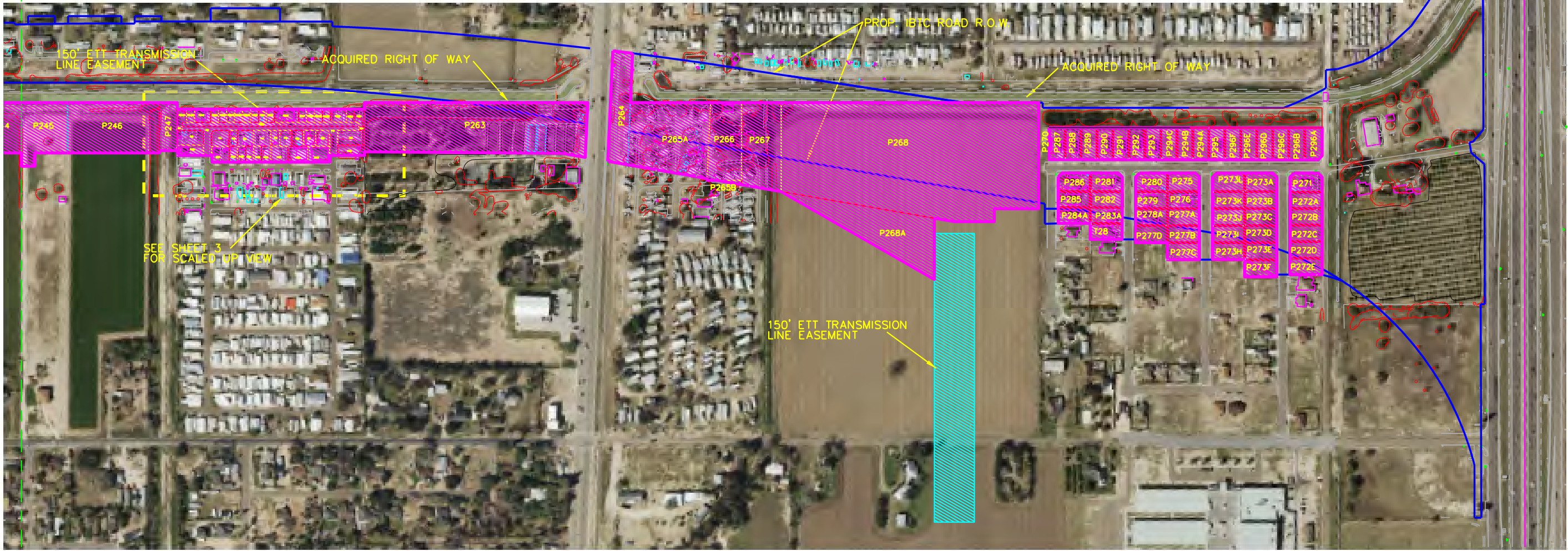

CONCEPTUAL EXHIBIT SHOWING I.B.T.C. ROADWAY RIGHT OF WAY AND ETT EASEMENT RIGHT OF WAY OWNED BY THE H.C.R.M.A.
NOT A BIDDING DOCUMENT.

INTERIM REVIEW ONLY
DOCUMENT INCOMPLETE! NOT INTENDED FOR PERMIT, BIDDING OR CONSTRUCTION.
ENGINEER: ERIC DAVILA, P.E.
P.E. SERIAL NO.: 115596
DATE: 04/11/2017



DANNENBAUM
ENGINEERING COMPANY - McALLEN, LLC
T.B.P.E. FIRM REGISTRATION #8999
1109 NOLANA LOOP, STE 200 McALLEN, TX 78504 (956) 662-3677

INTERNATIONAL BRIDGE TRADE CORRIDOR
HCRMA PROPOSED RIGHT OF WAY

DATE	BY	CHECKED	SCALE	SHEET NO.	TOTAL SHEETS
04/11/2017	ED	ED	AS SHOWN	142	2

TASK DESCRIPTION Surveying Services		Project Manager	Surveyor - Senior (RPLS)	Survey Technician Senior	CADD Operator	Administrative/Cle rical	TOTAL LABOR HRS AND COSTS	NO. OF DRAWINGS	LABOR HRS PER SHEET
NEGOTIATION YEAR 3&4									
CONTRACT RATE PER HOUR - SPECIFIED RATES									
CONTRACT RATE PER HOUR:		\$274.81	\$198.12	\$133.84	\$96.97	\$88.82			
130	FC 130 (130) - RIGHT-OF-WAY (ROW) DATA								
130.1	Right-of-Way Surveys (15.1.1)								
	Right of Entry								
	Prepare/submit boundary surveys and create Property Descriptions								
	Prepare/submit GIS files for ROWD/Real Property Assets Map System	2		16			18		
130.2	Right-of-Way Mapping - Traditional ROW map								
	Prepare/submit Preliminary Updated ROW Map showing existing and proposed ROW, baselines, proposed infrastructure improvements, and utilities	4	14	56			74	72	1.03
	Perform field surveying that monuments proposed ROW at PC, PT, PI, 1,500' Stations and ROW intersections		4	8			12		
	Prepare/submit Preliminary Property Descriptions that shall include metes and bounds descriptions and a parcel plat	8	16	40	220		284	620	0.46
	Prepare/submit Final Updated ROW Map showing existing and proposed ROW, baselines, proposed infrastructure improvements, and utilities	4	12	24			40	72	0.56
	Prepare/submit Final Property Descriptions that shall include metes and bounds descriptions and a parcel plat		8	8	40				
	Perform QAQC on ROW submittals as well as prepare a surveyors report regarding procedures, finding, and decisions made	8		8					
	Right-of-way Deliverables								
	Scanned copies of property ownership, right of entry information, and scanned field notes								
	Preliminary and final property description submittals								
	Initial and final right of way map submittals along with all required copies								
	Sub-Total	26	54	160	260		500		
	CONTRACT RATE PER HOUR	\$274.81	\$198.12	\$133.84	\$96.97	\$88.82	\$792.56		
	TOTAL LABOR COST	\$7,145.06	\$10,698.48	\$21,414.40	\$25,212.20		\$64,470.14		
	% Distribution of Staffing	5.2%	10.8%	32.0%	52.0%		100.0%		
	SUBTOTAL FC 130(130)						\$64,470.14		

TASK DESCRIPTION	2-PERSON SURVEY CREW	3-PERSON SURVEY CREW	TOTAL LABOR HRS	TOTAL LABOR COSTS
RIGHT OF WAY DATA - FC 130				
RIGHT OF WAY DATA				
FINAL PARCEL MONUMENTATION	40		40	\$6,762.40
HOURS SUB-TOTALS	40		40	
CONTRACT RATE PER HOUR	\$169.06	\$217.86		
TOTAL LABOR COSTS	\$6,762.40			\$6,762.40
% DISTRIBUTION OF STAFFING	100.0%		100.0%	
SUBTOTAL - FC 130				\$6,762.40

FC 130 (130) OTHER DIRECT EXPENSES	UNIT	RATE	QUANTITY	TOTAL
Lodging/Hotel - Taxes and Fees	day/person	\$45.00	6	\$270.00
Lodging/Hotel (Taxes/fees not included)	day/person	\$110.00	6	\$660.00
Meals (Excludes alcohol and tips) (Overnight stay required)	day/person	\$63.00	6	\$378.00
Mileage	mile	\$0.725	1200	\$870.00
Certified Letter Return Receipt	each	\$9.50		
Deed Copies	sheet	\$2.00		
Terrestrial Laser Scanner (rates applied to actual time scanner unit is in use)	hour	\$120.00		
SUBTOTAL - FC 130 (130) OTHER DIRECT EXPENSES				\$2,178.00

SUMMARY	
FC 130(130) TOTAL LABOR COSTS (DIRECT LABOR)	\$64,470.14
FC 130(130) TOTAL LABOR COSTS (UNIT COSTS)	\$6,762.40
FC 130(130) NON-SALARY (OTHER DIRECT EXPENSES)	\$2,178.00
GRAND TOTAL	\$73,410.54

Fw: **SH 68 (IBTC) Additional ROW Mapping Needed for RMA Transfer**

From Ramon Navarro, IV, PE, CFM <ramon.navarro@hcrma.net>
Date Wed 3/25/2026 3:03 PM
To Maria Alaniz <maria.alaniz@hcrma.net>
Cc Pilar Rodriguez, PE <prodriguez@hcrma.net>

@ 1 attachment (48 KB)

20260323 SURVEY 15-1IDP1007 SWA2 to WA4_SH68.xlsx;

Please place onto April agenda "Survey SH 68 (IBTC) Additional ROW Mapping Needed for RMA Transfer of Property".

TxDOT is requiring additional survey to detail each of the parcels for remainders. All remainders shall be removed from donation and remain HCRMA property. HCRMA survey list was depeleted, therefore we shall utilize McKim & Creed, Inc., TxDOT surveyor.

From: Ramon Navarro, IV, PE, CFM <ramon.navarro@hcrma.net>
Sent: Monday, March 23, 2026 9:20 AM
To: Pilar Rodriguez, PE <prodriguez@hcrma.net>
Cc: Maria Alaniz <maria.alaniz@hcrma.net>; Celia Gaona <celia.gaona@hcrma.net>; Ruben Alfaro <ruben.alfaro@hcrma.net>
Subject: Fw: SH 68 (IBTC) Additional ROW Mapping Needed for RMA Transfer

FYI
TxDOT steadfast on HCRMA paying for survey, **\$73,410.54**. We shall place onto next agenda (April 26) or administrative execution?

As per last discussion, our survey pool has been depleted, due to IBTC bid. We acquired proposal from TxDOT surveyor.

From: Ramon Jimenez Jr <Ramon.Jimenez@txdot.gov>
Sent: Monday, March 23, 2026 6:59 AM
To: Ramon Navarro, IV, PE, CFM <ramon.navarro@hcrma.net>
Cc: Maria Alaniz <maria.alaniz@hcrma.net>
Subject: RE: SH 68 (IBTC) Additional ROW Mapping Needed for RMA Transfer

Good morning Ramon,

I had an opportunity to discuss this item with Mr. Alvarez,

His recommendation is to have the RMA pay for the survey services that will allow the transfer of RMA acquired property within the SH 68 (IBTC) corridor, to the State.

Please advise of next steps.

From: Ramon Navarro, IV, PE, CFM <ramon.navarro@hcrma.net>
Sent: Tuesday, March 10, 2026 5:34 PM
To: Ramon Jimenez Jr <Ramon.Jimenez@txdot.gov>
Cc: Maria Alaniz <maria.alaniz@hcrma.net>
Subject: Re: SH 68 (IBTC) Additional ROW Mapping Needed for RMA Transfer

This email originated from outside of the organization. Do not click links or open attachments unless you recognize the sender and know the content is safe.

Followed up with Pilar, please speak to Mr. Alvarez.

From: Ramon Navarro, IV, PE, CFM <ramon.navarro@hcrma.net>
Sent: Tuesday, March 10, 2026 4:49 PM
To: Ramon Jimenez Jr <Ramon.Jimenez@txdot.gov>
Cc: Maria Alaniz <maria.alaniz@hcrma.net>
Subject: Re: SH 68 (IBTC) Additional ROW Mapping Needed for RMA Transfer

Yes, Board inquired as to why HCRMA had to pay for survey, if we were donating property. I explained that the land donation was part of our participating contribution. Pilar was going to speak to Mr. Alvarez. Let me follow-up...

From: Ramon Jimenez Jr <Ramon.Jimenez@txdot.gov>
Sent: Tuesday, March 10, 2026 2:47 PM
To: Ramon Navarro, IV, PE, CFM <ramon.navarro@hcrma.net>
Cc: Maria Alaniz <maria.alaniz@hcrma.net>
Subject: RE: SH 68 (IBTC) Additional ROW Mapping Needed for RMA Transfer

Good Afternoon Ramon,

I'm just checking to see if you were able to bring this item up in front of your board as you indicated in our last correspondence.

Thanks.

From: Ramon Navarro, IV, PE, CFM <ramon.navarro@hcrma.net>
Sent: Wednesday, February 11, 2026 4:22 PM

To: Ramon Jimenez Jr <Ramon.Jimenez@txdot.gov>
Cc: Maria Alaniz <maria.alaniz@hcrma.net>
Subject: Fw: SH 68 (IBTC) Additional ROW Mapping Needed for RMA Transfer

This email originated from outside of the organization. Do not click links or open attachments unless you recognize the sender and know the content is safe.

Thanks for follow-up! We shall take before our Board for consideration on 2/24/26 and provide a response immediately thereafter. If prior authorization is granted, we shall acknowledge. Please continue to collaborate as needed. THANKS

From: Ramon Jimenez Jr <Ramon.Jimenez@txdot.gov>
Sent: Wednesday, February 11, 2026 4:05 PM
To: Ramon Navarro, IV, PE, CFM <ramon.navarro@hcrma.net>
Subject: SH 68 (IBTC) Additional ROW Mapping Needed for RMA Transfer

Afternoon Ramon,

As per our conversation last week, here in attached is the estimate from our Contractor, McKim & Creed, Inc., for surveying services to produce a survey of all RMA owned properties within our SH 68 (Formally IBTC) project. The purpose of the survey is to delineate RMA owned ROW within the SH 68 corridor that will be included as an exhibit on the Deed that will be transfer said parcels to the State.

The attached estimate has been reviewed by our PM. The fee appears to be a reasonable based on scope of work requested.

Please advise if you need any other information or if you'd like to discuss said estimate.



Every mile matters. Learn more at DriveUkeATexan.com.

The information transmitted by this email is intended only for the person or entity to which it is addressed. This email may contain proprietary, confidential, and/or privileged material. If you received this message in error, do not use or rely upon it. Instead, please inform the sender and then delete it. Thank you.



Every mile matters. Learn more at DriveUkeATexan.com.

The information transmitted by this email is intended only for the person or entity to which it is addressed. This email may contain proprietary, confidential, and/or privileged material. If you received this message in error, do not use or rely upon it. Instead, please inform the sender and then delete it. Thank you.



Every mile matters. Learn more at DriveUkeATexan.com.

This Page
Intentionally
Left Blank

Item 4D

HIDALGO COUNTY REGIONAL MOBILITY AUTHORITY

AGENDA RECOMMENDATION FORM

BOARD OF DIRECTORS	<u> X </u>	WORKSHOP ITEM	<u> 4D </u>
PLANNING COMMITTEE	<u> </u>	DATE SUBMITTED	<u> 04/20/2026 </u>
FINANCE COMMITTEE	<u> </u>	MEETING DATE	<u> 04/28/2026 </u>
TECHNICAL COMMITTEE	<u> </u>		

1. Agenda Item: **RESOLUTION 2026-40 – CONSIDERATION AND APPROVAL OF CHANGE ORDER NUMBER 2 TO THE CONTRACT WITH SICE, INC. TO PROVIDE TOLL COLLECTION SYSTEM INSTALLATION, INTEGRATION, AND MAINTENANCE FOR THE 365 TOLLWAY PROJECT.**

2. Nature of Request: (Brief Overview) Attachments: Yes No
Consideration and approval of CO No. 2 to the contract with SICE, Inc. for the 365 Tollway Project.

3. Policy Implication: Board Policy, Local Government Code, Texas Government Code, Texas Transportation Code, TxDOT Policy

4. Budgeted: Yes No N/A

5. Staff Recommendation: **Motion to approve Resolution 2026-40 – Consideration and Approval of Change Order number 2 to the contract with SICE, Inc. to provide Toll Collection System Installation, Integration, and Maintenance for the 365 Tollway project, as presented.**

6. Program Manager’s Recommendation: Approved Disapproved None

7. Planning Committee’s Recommendation: Approved Disapproved None

8. Board Attorney’s Recommendation: Approved Disapproved None

9. Chief Auditor’s Recommendation: Approved Disapproved None

10. Chief Financial Officer’s Recommendation: Approved Disapproved None

11. Chief Development Engineer’s Recommendation: Approved Disapproved None

12. Chief Construction Engineer’s Recommendation: Approved Disapproved None

13. Executive Director’s Recommendation: Approved Disapproved None



Memorandum

To: Pilar Rodriguez, P.E.

From: Ruben Alfaro, P.E.

Date: April 20, 2026

Subject: Resolution 2026-40 Consideration and approval of order number 2 to the contract with SICE, Inc. to provide toll collection system installation, integration and maintenance for the 365 Tollway Project.

GOAL

To obtain approval of Change Order No. 2 to the existing contract with SICE, Inc. for toll collection system installation, integration, and maintenance services on the 365 Tollway Project. This change order incorporates additional items to compensate the contractor for project delays attributable to factors beyond their control.

HISTORY

On March 2, 2026, SICE, Inc. submitted a formal claim for additional compensation associated with extended project duration and resulting indirect costs. The claim is attributed to delays in the civil construction phase of the 365 Tollway Project.

Specifically, critical work areas required for the installation of tolling infrastructure—including gantries, conduit systems, and associated field equipment—have not reached sufficient completion to allow SICE to mobilize and perform installation, system integration, and testing activities. These delays have resulted in extended overhead, standby time, and inefficiencies impacting the contractor’s planned sequence of work.

PROPOSAL

The proposed Change Order No. 2 includes the addition of negotiated pay items to the contract to address delay-related costs incurred by SICE, Inc. The change order also provides for a contract time extension of twelve (12) months to accommodate the revised construction schedule and ensure proper completion of system installation, integration, and commissioning.

RECOMMENDATION

Staff recommends approval of Change Order No. 2 in the amount of **\$1,227,043.45** to compensate SICE, Inc. for delay-related impacts associated with the civil construction phase and to extend the contract duration by twelve (12) months.



Contractor _____

CONSTRUCTION CONTRACT AMENDMENT SUMMARY

RESOLUTION 2026-40

Original Contract Amount \$ 13,980,669

Change Order No. 2

Amount \$ 1,227,043.45

Approved Amendments:

Resolution No.	Description	Amount
2024-24	Single Gantry Structures and Vehicle Class systems	\$ 645,171.17

Subtotal from Cont. Page \$ 0.00

Contract Amount **\$ 14,625,840.17**

Proposed Amendment

2026-40	Project Schedule Extension and economic impact	 \$ 1,227,043.45
---------	--	--

Goal and Options:

Based on existing Civil construction delays, this change order provides a project schedule extension and economic impact compensation through the new Go-Live schedule of January 1, 2027.

RECOMMENDATION:

REASON FOR REQUEST:

Staff is recommending approval of this request in the amount of \$ 1,227,043.45 for a Revised Contract Amount of \$ 15,852,883.62

Ruben Alfaro, P.E.

Requested by:

HIDALGO COUNTY REGIONAL MOBILITY AUTHORITY
BOARD RESOLUTION No. 2026 - 40

CONSIDERATION AND APPROVAL OF CHANGE ORDER
NUMBER 2 TO THE CONTRACT WITH SICE, INC. TO PROVIDE
TOLL COLLECTION SYSTEM INSTALLATION, INTEGRATION
AND MAINTENANCE FOR THE 365 TOLLWAY

THIS RESOLUTION is adopted this 28th day of April, 2026 by the Board of Directors of the Hidalgo County Regional Mobility Authority.

WHEREAS, the Hidalgo County Regional Mobility Authority (the “Authority”), acting through its Board of Directors (the “Board”), is a regional mobility authority created pursuant to Chapter 370, Texas Transportation Code, as amended (the “Act”); and

WHEREAS, on November 17, 2005, the Texas Transportation Commission (the “Commission”) created the Authority pursuant to (i) the Act; (ii) Title 43, Texas Administrative Code; (iii) a petition of the Hidalgo County Commissioners Court (the “County”); and (iv) findings by the Commission that the creation of the Authority would result in certain direct benefits to the State of Texas (the “State”), local governments, and the traveling public and would improve the State’s transportation system; and

WHEREAS, the Act allows the Authority to construct transportation projects within the County, including the 365 Tollway Project (the “Project”); and

WHEREAS, the Authority issued a competitive, best value procurement, RFP 2022-02: Toll Collection System Installation, Integration, and Maintenance for the Project (the “RFP”); and

WHEREAS, the Authority received five qualified responses to the RFP;

WHEREAS, on March 14, 2023, the evaluation committee recommended SICE as the best value respondent and the Board authorized the Authority to enter into negotiations with SICE Inc.; and

WHEREAS, a contract was negotiated with SICE Inc. for Toll Collection System Installation, Integration, and Maintenance for the Project (the “Contract”);

WHEREAS, on April 25, 2023, the Authority approved Resolution 2023-22 Award of Contract for the 365 Tollway Toll Collection System Installation, Integration and Maintenance Contract to SICE Inc.; and

WHEREAS, the Authority passed Resolution 2024-24 to approve Change Order number one (1) to the contract with SICE, Inc for the toll collection system installation, integration and maintenance for the 365 tollway project. Change Order number one (1) introduced a

single-gantry (monogantry) structure at each location and a system of classifying vehicles based on axles and height to provide net capital cost savings, increased revenue, and maintained system accuracy. Change order number one (1) proves a maximum increase in the amount of \$645,170.00; and

WHEREAS , the Authority finds it necessary to approve Resolution 2026-40, Consideration and Approval of Change Order number two (2) to the contract with SICE, Inc. for the toll collection system installation, integration and maintenance for the 365 tollway project. This Change Order represents a project schedule and economic impact compensation for the construction delay and updated Go-Live date for the toll collection system up to January 1, 2027. Change order number two (2) proves a maximum increase in the amount of \$1,227,043.45;

NOW THEREFORE BE IT RESOLVED BY THE BOARD OF DIRECTORS
OF THE HIDALGO COUNTY REGIONAL MOBILITY AUTHORITY THAT:

Section 1. The recital clauses are incorporated in the text of this Resolution as if fully restated.

Section 2. The Board hereby approves Change Order number 2 to the contract with SICE, Inc. for the 365 Tollway Toll Collection System Installation, Integration and Maintenance in the amount of \$1,227,043.45, attached hereto as Exhibit A.

Section 3. The Board authorizes the Executive Director to execute Change Order number 2.

PASSED AND APPROVED AS TO BE EFFECTIVE IMMEDIATELY BY THE BOARD OF DIRECTORS OF THE HIDALGO COUNTY REGIONAL MOBILITY AUTHORITY AT A REGULAR MEETING on the 28th day of April, 2026, at which meeting a quorum was present.

Robert L. Lozano, Chairman

Michael Williamson, Secretary/Treasurer

Exhibit A

Change Order Number 2
to the Contract with
SICE, INC.
for Toll Collection System
Installation, Integration and
Maintenance for the 365
Tollway Project

CONSTRUCTION CONTRACT CHANGE ORDER NUMBER: 2

1. Contract Information

LG Contract No: 2022-02 County: Hidalgo
CCSJ: _____ District: Pharr
Project No: 2022-02 Highway: _____
Contractor: SICE, Inc.

2. Change Order Work Limits: Station _____ to Station _____

3. Describe the change(s) and the reason for the Change Order. When necessary, include exceptions to this agreement.

Time Ext. #: 1 # of Days Added: 365 Time Impact Analysis attached: (Yes/No): N/A

Amount added by this Change Order: \$ 1,227,043.45

4. New or revised plan sheet(s) attached: _____

5. Change Order Authorizations: Each signatory hereby warrants that each has the authority to execute this Change Order.

By signing this change order, the contractor agrees to waive any and all claims or additional compensation due to any and all other expenses; additional changes for time; overhead and profit; or loss of compensation as a result of this change. Further, the contractor agrees that this agreement is made in accordance with the Contract. Exceptions should be noted in the response for item 3 above.

THE CONTRACTOR

Signature: _____ Date: _____
Typed/Printed Name: _____
Typed/Printed Title: _____

THE OWNER

Recommended for Execution:

Approved:

Ruben Alfaro, PE Development Engineer
Signature/Title _____ Date: 04-20-26

Pilar Rodriguez, Executive Director
Signature /Title _____ Date: _____

Signature /Title _____ Date: _____

Signature /Title _____ Date: _____

Signature /Title _____ Date: _____

Signature _____ Date: _____

Signature /Title _____ Date: _____

Signature /Title _____ Date: _____

Engineer's Seal:



HCRMA-365 TCS
PROJECT EXTENSION
(365Toll-COR-001) V2

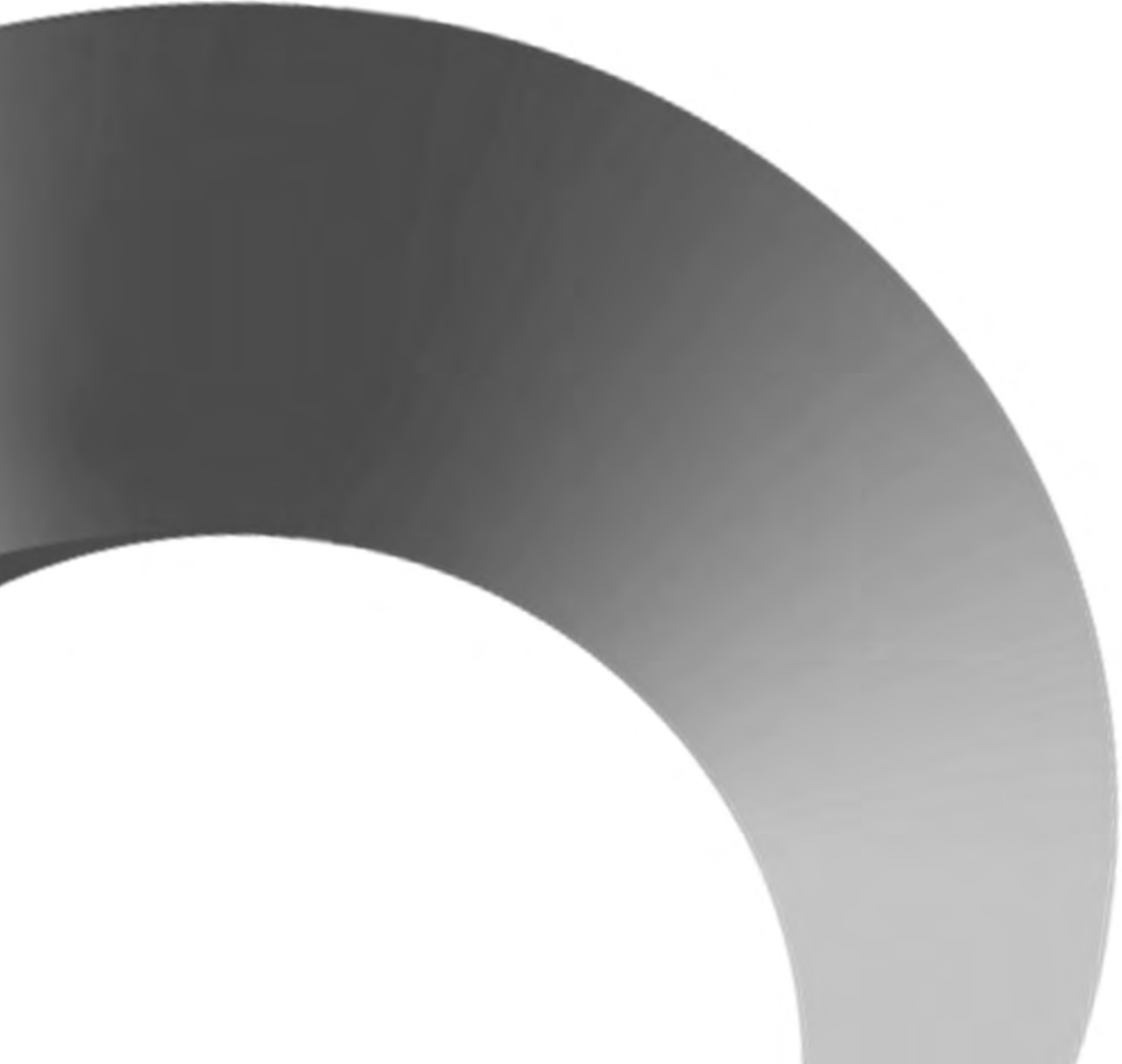

TABLE OF CONTENTS

1	PURPOSE	2
2	ASSUMPTIONS USED IN THE DEVELOPMENT OF THE PROPOSAL	2
3	REVISED PROJECT SCHEDULE	2
4	SCHEDULE OF PAYMENT	3

1 PURPOSE

The purpose of this document is to present a revised project schedule and economic impact in response to HCRMA updated toll collection system revenue commencement date (Go-Live) of January 1, 2026 to January 1, 2027 with a Soft Go-Live Date of October 1, 2026. In this context the Soft Go-Live Date will indicate that the system is ready in all respects to do revenue collection on that date,

2 ASSUMPTIONS USED IN THE DEVELOPMENT OF THE PROPOSAL

For developing the proposal, SICE has taken into account the following considerations:

- 1) Soft Go-Live will be considered the project Go-Live and follow all pertinent procedures
- 2) From the Soft Go-Live date until the start of Revenue Collection, 365TCS will be fully operational and maintained, therefore Soft Go-Live will trigger the commencement of Maintenance Services.
- 3) During this period, system will generate transactions, but they will not be sent to Production CBOS for processing. If CBOS QA environment is available, transactions could be sent there for testing and fine-tuning purposes.
- 4) PHS PROD and QA environments will be available at Soft Go-Live and any transaction flow configuration and reconfiguration required during the testing period are included.
- 5) Soft Go-Live will trigger the commencement of Maintenance Services.
- 6) Remaining scope and monthly fee escalations have been calculated using Employment Cost Index (ECI) for Q4 2024 and for Q3 2025 to account for the 9month project extension.
- 7) A new development and testing cycle has been considered in order to complete the integration with HCTRA and to implement a reconciliation process with them.
- 8) Schedule of payment quantities covers for the possibility of Soft Go-Live not happening until system revenue commencement date on January 1, 2026. Total quantities invoice will depend on final Soft Go-Live date.

3 REVISED PROJECT SCHEDULE

Together with this document a revised project schedule is being delivered.

4 SCHEDULE OF PAYMENT

The following table shows SICE proposal for the design, development, testing and deployment of the large commercial vehicle classification system at RSE and TBOS level.

Economic Proposal				Sale prices	
ID	ITEM	Unit	Qtys.	Unit price	Item price total
Project Delay					
1	Remaining scope ECI escalation	LS	1	\$138,864.87	\$138,864.87
2	Extended monthly fee (ECI escalated)	Monthly	12	\$39,877.65	\$478,531.74
3	Disruption & Inefficiency Costs	Monthly	12	\$22,321.43	\$267,857.14
4	Monthly extension hardware warranty	Monthly	12	\$17,732.04	\$212,784.50
5	CBOS interface: -Isolated development and testing cycle -Regression testing	LS	1	\$81,152.60	\$81,152.60
6	Extended insurance cost	LS	1	\$21,960.76	\$21,960.76
7	Bond	LS	1	\$8,852.54	\$8,852.54
8	Bond extension surcharge	Monthly	12	\$1,420.00	\$17,040.00

This Page
Intentionally
Left Blank

Item 4E

HIDALGO COUNTY REGIONAL MOBILITY AUTHORITY

AGENDA RECOMMENDATION FORM

BOARD OF DIRECTORS
PLANNING COMMITTEE
FINANCE COMMITTEE
TECHNICAL COMMITTEE

 X

WORKSHOP ITEM
DATE SUBMITTED
MEETING DATE

 4E
 04/20/2026
 04/28/2026

1. Agenda Item: **RESOLUTION 2026-41 – CONSIDERATION AND APPROVAL OF CHANGE ORDER NUMBER 3 TO THE CONTRACT WITH SICE, INC. TO PROVIDE TOLL COLLECTION SYSTEM INSTALLATION, INTEGRATION, AND MAINTENANCE FOR THE 365 TOLLWAY PROJECT.**

2. Nature of Request: (Brief Overview) Attachments: Yes No
Consideration and approval of CO No. 3 to the contract with SICE, Inc. for the 365 Tollway Project.

3. Policy Implication: Board Policy, Local Government Code, Texas Government Code, Texas Transportation Code, TxDOT Policy

4. Budgeted: Yes No N/A

5. Staff Recommendation: **Motion to approve Resolution 2026-41 – Consideration and Approval of Change Order number 3 to the contract with SICE, Inc. to provide Toll Collection System Installation, Integration, and Maintenance for the 365 Tollway project, as presented.**

6. Program Manager’s Recommendation: Approved Disapproved None

7. Planning Committee’s Recommendation: Approved Disapproved None

8. Board Attorney’s Recommendation: Approved Disapproved None

9. Chief Auditor’s Recommendation: Approved Disapproved None

10. Chief Financial Officer’s Recommendation: Approved Disapproved None

11. Chief Development Engineer’s Recommendation: Approved Disapproved None

12. Chief Construction Engineer’s Recommendation: Approved Disapproved None

13. Executive Director’s Recommendation: Approved Disapproved None



Memorandum

To: Pilar Rodriguez, P.E.

From: Ruben Alfaro, P.E.

Date: April 20, 2026

Subject: Resolution 2026-40 Consideration and approval of order number 2 to the contract with SICE, Inc. to provide toll collection system installation, integration and maintenance for the 365 Tollway Project.

GOAL

To obtain approval of Change Order No. 3 to the existing contract with SICE, Inc. for toll collection system installation, integration, and maintenance services for the 365 Tollway Project. This change order incorporates a revised economic impact resulting from modifications to the toll system Operations and Maintenance (O&M) requirements.

HISTORY

At the direction of the Hidalgo County Regional Mobility Authority (HCRMA), SICE, Inc. performed an evaluation of cost impacts associated with proposed scope modifications, including the removal of Image Review requirements during the O&M phase and the simplification of the system interface with the Central Back Office System (CBOS) operated by the Harris County Toll Road Authority (HCTRA).

These modifications are intended to streamline operational processes, reduce system complexity, and improve long-term maintenance efficiency. Based on these changes, SICE, Inc. developed a revised economic impact assessment reflecting adjustments to the original contract scope and associated costs.

PROPOSAL

Change Order No. 3 provides for the removal of Image Review requirements under the SICE, Inc. contract and the simplification of system integration requirements with the HCTRA CBOS interface.

These scope reductions result in a corresponding decrease in contract cost and adjustments to the overall O&M requirements.

RECOMMENDATION

Staff recommends approval of Change Order No. 3 in the amount of **(\$347,070.00)**, reflecting a net reduction in the contract amount associated with the revised scope of work for the SICE, Inc. contract.



Contractor SICE, Inc.

CONSTRUCTION CONTRACT AMENDMENT SUMMARY

RESOLUTION 2026-41

Original Contract Amount \$ 13,980,669

Change Order No. 3

Amount -\$ 347,070.00

Approved Amendments:

Resolution No.	Description	Amount
2024-24	Single Gantry Structures and Vehicle Class systems	\$ 645,171.17
2026-40	Project Schedule Extension and economic impact	\$ 1,227,043.45

Subtotal from Cont. Page \$ 0.00

Contract Amount **\$ 15,852,883.62**

Proposed Amendment

2026-41	Image Review Elimination	-\$ 347,070.00
---------	--------------------------	-----------------------

Goal and Options:

Removal of image Review requirements during the O&M phase and the simplification of the system interface with the Central Back Office System (CBOS) operated by the Harris County Toll Road Authority (HCTRA).

**Staff is recommending approval of this request in the amount of -\$ 347,070.00
for a Revised Contract Amount of \$ 15,505,813.62**

Ruben Alfaro, P.E.

Requested by:

HIDALGO COUNTY REGIONAL MOBILITY AUTHORITY
BOARD RESOLUTION No. 2026 - 41

CONSIDERATION AND APPROVAL OF CHANGE ORDER
NUMBER 3 TO THE CONTRACT WITH SICE, INC. TO PROVIDE
TOLL COLLECTION SYSTEM INSTALLATION, INTEGRATION
AND MAINTENANCE FOR THE 365 TOLLWAY

THIS RESOLUTION is adopted this 28th day of April, 2026 by the Board of Directors of the Hidalgo County Regional Mobility Authority.

WHEREAS, the Hidalgo County Regional Mobility Authority (the “Authority”), acting through its Board of Directors (the “Board”), is a regional mobility authority created pursuant to Chapter 370, Texas Transportation Code, as amended (the “Act”); and

WHEREAS, on November 17, 2005, the Texas Transportation Commission (the “Commission”) created the Authority pursuant to (i) the Act; (ii) Title 43, Texas Administrative Code; (iii) a petition of the Hidalgo County Commissioners Court (the “County”); and (iv) findings by the Commission that the creation of the Authority would result in certain direct benefits to the State of Texas (the “State”), local governments, and the traveling public and would improve the State’s transportation system; and

WHEREAS, the Act allows the Authority to construct transportation projects within the County, including the 365 Tollway Project (the “Project”); and

WHEREAS, the Authority issued a competitive, best value procurement, RFP 2022-02: Toll Collection System Installation, Integration, and Maintenance for the Project (the “RFP”); and

WHEREAS, the Authority received five qualified responses to the RFP;

WHEREAS, on March 14, 2023, the evaluation committee recommended SICE as the best value respondent and the Board authorized the Authority to enter into negotiations with SICE Inc.; and

WHEREAS, a contract was negotiated with SICE Inc. for Toll Collection System Installation, Integration, and Maintenance for the Project (the “Contract”);

WHEREAS, on April 25, 2023, the Authority approved Resolution 2023-22 Award of Contract for the 365 Tollway Toll Collection System Installation, Integration and Maintenance Contract to SICE Inc.; and

WHEREAS, the Authority passed Resolution 2024-24 to approve Change Order number one (1) to the contract with SICE, Inc for the toll collection system installation, integration and maintenance for the 365 tollway project. Change Order number one (1) introduced a

single-gantry (monogantry) structure at each location and a system of classifying vehicles based on axles and height to provide net capital cost savings, increased revenue, and maintained system accuracy. Change order number one (1) proves a maximum increase in the amount of \$645,170.00; and

WHEREAS , the Authority finds it necessary to approve Resolution 2026-41, Consideration and Approval of Change Order number three (3) to the contract with SICE, Inc. for the toll collection system installation, integration and maintenance for the 365 tollway project. This Change Order represents a scope reduction, removing the Image review, to be performed through HCTRA's back office. Change order number three (3) proves a net reduction in the amount of \$347,070;

NOW THEREFORE BE IT RESOLVED BY THE BOARD OF DIRECTORS
OF THE HIDALGO COUNTY REGIONAL MOBILITY AUTHORITY THAT:

Section 1. The recital clauses are incorporated in the text of this Resolution as if fully restated.

Section 2. The Board hereby approves Change Order number 3 to the contract with SICE, Inc. for the 365 Tollway Toll Collection System Installation, Integration and Maintenance in the amount of (\$347,070.00) attached hereto as Exhibit A.

Section 3. The Board authorizes the Executive Director to execute Change Order number 3.

PASSED AND APPROVED AS TO BE EFFECTIVE IMMEDIATELY BY THE BOARD OF DIRECTORS OF THE HIDALGO COUNTY REGIONAL MOBILITY AUTHORITY AT A REGULAR MEETING on the 28th day of April, 2026, at which meeting a quorum was present.

Robert L. Lozano, Chairman

Michael Williamson, Secretary/Treasurer

Exhibit A

Change Order Number 3
to the Contract with
SICE, INC.
for Toll Collection System
Installation, Integration and
Maintenance for the 365
Tollway Project

CONSTRUCTION CONTRACT CHANGE ORDER NUMBER: 3

1. Contract Information

LG Contract No: 2022-02 County: Hidalgo
CCSJ: _____ District: Pharr
Project No: 2022-02 Highway: _____
Contractor: SICE, Inc.

2. Change Order Work Limits: Station _____ to Station _____

3. Describe the change(s) and the reason for the Change Order. When necessary, include exceptions to this agreement.

Time Ext. #: N/A # of Days Added: N/A Time Impact Analysis attached: (Yes/No): N/A

Amount added by this Change Order: \$ (347,070.00)

4. New or revised plan sheet(s) attached: _____

5. Change Order Authorizations: Each signatory hereby warrants that each has the authority to execute this Change Order.

By signing this change order, the contractor agrees to waive any and all claims or additional compensation due to any and all other expenses; additional changes for time; overhead and profit; or loss of compensation as a result of this change. Further, the contractor agrees that this agreement is made in accordance with the Contract. Exceptions should be noted in the response for item 3 above.

THE CONTRACTOR

Signature: _____ Date: _____
Typed/Printed Name: _____
Typed/Printed Title: _____

THE OWNER

Recommended for Execution:

Approved:

Ruben Alfaro, PE Development Engineer
Signature/Title _____ Date: 04-20-26

Pilar Rodriguez, Executive Director
Signature /Title _____ Date: _____

Signature /Title _____ Date: _____

Signature /Title _____ Date: _____

Signature /Title _____ Date: _____

Signature _____ Date: _____

Signature /Title _____ Date: _____

Signature /Title _____ Date: _____

Engineer's Seal:



HCRMA-365 TCS

IR SCOPE REDUCTION AND CBOS DISPOSITION & TVL REMOVAL

(365ToII-COR-002) V1

TABLE OF CONTENTS

1	PURPOSE	2
2	SCHEDULE OF PAYMENT	3
2.1	CBOS INTERFACE SIMPLIFICATION	3
2.2	IMAGE REVIEW REQUIREMENT REMOVAL	3

1 PURPOSE

The purpose of this document is to present a revised economic impact in response to HCRMA request for removal of Image Review requirements during O&M phase and the simplification of the interface with the CBOS (HCTRA).

The following list outlines the proposed removals and updates to existing requirements. These items form the basis for the revised economic impact assessment.

1. Eliminate the Image Review Supervisor as a key role (General Provisions 03-16)
2. Eliminate the requirements for the TCS Project Host Server (PHS) to automatically reconcile transactions from the Third-Party BOS
 - a. This eliminates the requirement in GP Section 05-4
 - b. Modify the requirement for reconciliation reporting in GP Section 05-07 to eliminate the reconciliation between the PHS and Third-Party BOS. Instead the system reporting should support manual reconciliation by reporting on data sent to the BOS.
 - c. Eliminate the requirements for testing automated PHS to Third-Party BOS reconciliation in GP Section 06-1.5.
 - d. Eliminate the requirement for the TCS to process transaction files to reconcile transactions sent to the Third-Party BOS, GP Section 07-5.4.
3. Eliminate the requirements for manual Image Review
 - a. Eliminate manual image review requirements from GP Section 05-6.
 - b. Eliminate reporting for manual image review performance (e.g. REQ-245).
 - c. Optical Character Recognition requirements should remain and be sent to the BOS in accordance with the ICD.
4. Eliminate the processing of a TVL file, instead sending images with all transactions to allow HCTRA to determine final transaction type (AVI vs Image).
5. Update the Concept of Operations
6. Update the Detailed Functional Design Documents the System Design Documents for the components listed below
 - a. Requirements Traceability Matrix
 - b. Business Rules Document
 - c. MOMS Systems Design Document
 - d. RSS Systems Design Document
 - e. TBOS Systems Design Document
 - f. TBOS-CBOS Interface Control Document
 - g. Reports System Design Document
7. Update the remaining Test Plans and Scripts accordingly



2 SCHEDULE OF PAYMENT

2.1 CBOS INTERFACE SIMPLIFICATION

The removal of the TVL file exchange and the removal of the interface for reconciliation will reduce the effort to complete the integration with HCTRA. As a result, SICE proposed a reduction of **\$40,000.00** from *Item #5 of CO 2 - Schedule Delay Claim and Extension* on which the above works had been previously priced.

2.2 IMAGE REVIEW REQUIREMENT REMOVAL

With the removal of Image Review, the PHS will process and submit all transponder and video transactions to HCTRA CBOS independently if the lane-level OCR system was able to obtain LPN information for the vehicle and in the positive case, independently of the reliability score achieved.

SICE will continue to maintain and update the RSE OCR licenses as well as to monitor and audit the image capture system and OCR to ensure that their respective KPIs are met.

Taking this into account, SICE proposes to modify *Schedule D: Maintenance Pricing*, removing the variable fee associated with Image Base Transaction Processing and replace it with a fix monthly fee of \$1,792.00 as compensation for the activities mentioned above.

Schedule D: Maintenance Pricing

#	Maintenance Component	Maintenance & Warranty			1st Maintenance Period			2nd Maintenance Period			3rd Maintenance Period			4th Maintenance Period		
		Unit Price	UOM or # of Months	Annual Price	Unit Price	UOM or # of Months	Annual Price	Unit Price	UOM or # of Months	Annual Price	Unit Price	UOM or # of Months	Annual Price	Unit Price	UOM or # of Months	Annual Price
1	Network Systems Maintenance	\$ 3,125.00	12	\$37,500	\$ 3,219.00	12	\$38,628	\$ 3,315.00	12	\$39,780	\$ 3,415.00	12	\$40,980	\$ 3,517.00	12	\$42,204
2	TCS Hardware Maintenance	\$ 30,141.00	12	\$361,692	\$ 27,069.00	12	\$324,828	\$ 29,440.00	12	\$353,280	\$ 31,634.00	12	\$382,008	\$ 33,472.00	12	\$401,664
3	TCS Software maintenance. Includes all application and system software.	\$ 35,453.00	12	\$425,436	\$ 36,516.00	12	\$438,192	\$ 37,612.00	12	\$451,344	\$ 38,740.00	12	\$464,880	\$ 39,902.00	12	\$478,824
4	Project Management	\$ 16,574.00	12	\$198,888	\$ 17,071.00	12	\$204,852	\$ 17,583.00	12	\$210,996	\$ 18,111.00	12	\$217,332	\$ 18,654.00	12	\$223,848
5	Cost per Image Based Transaction (IBT)*	\$0.0299	2,400,000	\$66,790	\$0.0299	2,760,000	\$77,290	\$0.0299	2,900,000	\$85,550	\$0.0299	3,000,000	\$91,200	\$0.0315	3,000,000	\$95,900
5	Image Based Transaction Processing Fixed Fee	\$ 1,792.00	12	\$21,504	\$ 1,792.00	12	\$21,504	\$ 1,792.00	12	\$21,504	\$ 1,792.00	12	\$21,504	\$ 1,792.00	12	\$21,504
Subtotal Annual TCS Maintenance Price				\$1,045,020		\$1,028,004		\$1,076,904		\$1,126,704		\$1,168,044				

This Page
Intentionally
Left Blank

Item 4F

HIDALGO COUNTY REGIONAL MOBILITY AUTHORITY

AGENDA RECOMMENDATION FORM

BOARD OF DIRECTORS	<u> X </u>	AGENDA ITEM	<u> 4F </u>
PLANNING COMMITTEE	<u> </u>	DATE SUBMITTED	<u> 4/20/2026 </u>
FINANCE COMMITTEE	<u> </u>	MEETING DATE	<u> 4/28/2026 </u>
TECHNICAL COMMITTEE	<u> </u>		

1. Agenda Item: **RESOLUTION 2026-42 – CONSIDERATION AND APPROVAL OF AN AGREEMENT WITH AEP TEXAS, INC., TO INSTALL ELECTRIC DISTRIBUTION FACILITIES FOR NEW ELECTRICAL SERVICES FOR THE 365 TOLL PROJECT.**

2. Nature of Request: (Brief Overview) Attachments: Yes No
Approval of Resolution 2026-42 for an agreement AEP Texas, Inc.

3. Policy Implication: Board Policy, Local Government Code, Texas Government Code, Texas Transportation Code, TxDOT Policy

4. Budgeted: Yes No N/A

5. Staff Recommendation: **Motion to approve Resolution 2026-42 – Consideration and approval of an agreement with AEP Texas, Inc., to install electrical distribution facilities for new electrical services for the 365 Tollway Projec, as presented.**

6. Program Manager’s Recommendation: Approved Disapproved None

7. Planning Committee’s Recommendation: Approved Disapproved None

8. Board Attorney’s Recommendation: Approved Disapproved None

9. Chief Auditor’s Recommendation: Approved Disapproved None

10. Chief Financial Officer’s Recommendation: Approved Disapproved None

10. Chief Development Engineer’s Recommendation: Approved Disapproved None

11. Chief Construction Engineer’s Recommendation: Approved Disapproved None

12. Executive Director’s Recommendation: Approved Disapproved None



TO: Pilar Rodriguez, PE, Executive Director

FROM: Ramon Navarro IV, P.E. Chief Construction Engineer

DATE: April 21, 2026

SUBJECT: Summary of Agenda Item – Resolution 2026-42 - Consideration and approval of agreement with AEP Texas, Inc. to Install Electric Distribution Facilities for New Electrical Services for the 365 Tollway Project

Background

On June 24, 2024, the Board of Directors of the Hidalgo County Regional Mobility Authority (HCRMA) adopted Resolution No. 2025-44, approving an agreement with AEP Texas, Inc. to provide electric distribution infrastructure necessary for the 365 Tollway Project, a major regional mobility initiative authorized under Chapter 370 of the Texas Transportation Code.

The Authority approved Resolution 2025-44 approval of agreement with AEP Texas, Inc. to install electric distribution facilities for new electrical services for the 365 Tollway Project;

WR #88984383 – SHARY RD @ SH 365 \$30,214.32 - **Revised 26,031.11**
WR #89131082 – GLASSCOCK RD @ SH 365 \$74,452.77 - **Revised 71,125.22**

On January 27, 2026 Resolution 2026-17 was approved, authoring three additional locations:

WR #90919277 – Ware Road @ SH 365 \$57,431.03 - **Revised 39,532.26**
WR#90894282 - Bentsen @ SH365 \$19,257.71 - **Revised 13,948.81**
WR#90883174 - 10th Street @ SH365 \$95,285.10 - **Revised 73,177.61**

On February 24, 2026 Resolution 2026-22 was approved, authorizing one additional location:

WR # 90605590 - Anzalduas Connector: \$43,596.30

On March 24, 2026 Resolution 2026-37 was approved, authorizing one additional location:

WR # 90916128 – SH365 Pharr- 4” Bore: \$33,883.90

Goal

AEP Texas is proposing to execute the installation of new electrical distribution facilities to power illumination and Transportation Management System (TMS) components along 365 Tollway Las Milpas South to US 281 Military Highway.

WR # 91614423 – Las Milpas S to US 281 Military Hwy: \$58,737.55

Overall Total to Date: \$360,032.76

We are still anticipating two more invoices for new locations.

Board Action

Staff recommends approval of Resolution 2026-42, an agreement with AEP Texas, Inc. to install electric distribution facilities for new electrical services for the 365 Tollway Project; and authorized the Executive Director to execute and finalize all associated documents necessary for implementation of the project elements.

HIDALGO COUNTY REGIONAL MOBILITY AUTHORITY
BOARD RESOLUTION No. 2026-42

**CONSIDERATION AND APPROVAL OF AGREEMENT WITH AEP TEXAS,
INC. TO INSTALL ELECTRIC DISTRIBUTION FACILITIES FOR NEW
ELECTRICAL SERVICES FOR THE 365 TOLLWAY PROJECT**

THIS RESOLUTION is adopted this 28th day of April, 2026 by the Board of Directors of the Hidalgo County Regional Mobility Authority.

WHEREAS, the Hidalgo County Regional Mobility Authority (the "Authority"), acting through its Board of Directors (the "Board"), is a regional mobility authority created pursuant to Chapter 370, Texas Transportation Code, as amended (the "Act"); and

WHEREAS, on November 17, 2005, the Texas Transportation Commission (the "Commission") created the Authority pursuant to (i) the Act; (ii) Title 43, Texas Administrative Code; (iii) a petition of the Hidalgo County Commissioners Court (the "County"); and (iv) findings by the Commission that the creation of the Authority would result in certain direct benefits to the State of Texas (the "State"), local governments, and the traveling public and would improve the State's transportation system; and

WHEREAS, the Act allows the Authority to construct transportation projects within the County, including the 365 Tollway Project (the "Project"); and

WHEREAS, on August 29, 2017 the Authority approved Resolution 2017-73, pursuant to Sections 370.033 and 370.170 of the Act, the Authority has the power and authority to request an implement the relocation of a public utility facility located in, on, along, over, or under the Project;

WHEREAS, AEP Texas Inc. is eligible for Federal Aid cost participation in accordance with the provisions of 23 CFR 645 A&B. The utility has right of occupancy in its existing location as it holds an easement, or another real property interest, therefore the eligibility ratio is 50%;

WHEREAS, on March 28, 2023 the Board of Directors approved Resolution 2023-16, approval of an Agreement with AEP Texas Inc. for participation in relocation of electrical distribution line at Glasscock Road for the 365 Tollway in the amount of \$65,415.65;

WHEREAS, on May 16, 2025 AEP Texas presented an agreement titled "Contribution-In-Aid-Of-Construction Agreement For Electric Distribution Service" between Hidalgo County Regional Mobility Authority (HCRMA) and AEP Texas to design and install electrical distribution facilities for providing new electrical services for the 365 Tollway Project.

WHEREAS, on June 24, 2025 the Authority considered and approved Resolution 2025-44, professional agreement between Hidalgo County Regional Mobility Authority (HCRMA) and AEP Texas. for participation in relocation of electrical distribution lines for the 365 Tollway in the amount of \$104,667.09

WHEREAS, on January 27, 2026 the Authority approved Resolution 2026-17, professional agreement between Hidalgo County Regional Mobility Authority (HCRMA) and AEP Texas, Inc. for installation of electrical distribution facilities for new electrical services for the 365 Tollway in the amount of \$171,973.84; and

WHEREAS, on February 24, 2026 the Authority approved Resolution 2026-22, professional agreement between Hidalgo County Regional Mobility Authority (HCRMA) and AEP Texas, Inc. for installation of electrical distribution facilities for new electrical services for the 365 Tollway in the amount of \$43,596.30; AND

WHEREAS, on March 24, 2026 the Authority approved Resolution 2026-37, professional agreement between Hidalgo County Regional Mobility Authority (HCRMA) and AEP Texas, Inc. for installation of electrical distribution facilities for new electrical services for the 365 Tollway in the amount of \$33,883.90; and

WHEREAS, the Authority finds it necessary to approve Resolution 2026-42, professional agreement between Hidalgo County Regional Mobility Authority (HCRMA) and AEP Texas, Inc. for installation of electrical distribution facilities for new electrical services for the 365 Tollway in the amount of \$58,737.55;

NOW THEREFORE BE IT RESOLVED BY THE BOARD OF DIRECTORS OF THE HIDALGO COUNTY REGIONAL MOBILITY AUTHORITY THAT:

- SECTION 1. The recital clauses are incorporated in the text of this Resolution as if fully restated.
- SECTION 2. The Board hereby approves Resolution 2026-42, Approval of agreement with AEP Texas Inc. for \$58,737.55 in design, and installation of electrical distribution facilities for providing new electrical services for the 365 Tollway Project.
- SECTION 3. This amount is based on excess cost beyond standard utility service provisions under AEP's tariff with the Public Utilities Commission of Texas.
- SECTION 4. HCRMA will not gain ownership or control over the installed facilities. AEP retains full ownership and utility usage rights.
- SECTION 5. Upon final review by legal counsel, the Board hereby authorizes the Executive Director to execute and finalize the authorized construction contract with AEP Texas Inc.

PASSED AND APPROVED AS TO BE EFFECTIVE IMMEDIATELY BY THE BOARD OF DIRECTORS OF THE HIDALGO COUNTY REGIONAL MOBILITY AUTHORITY AT A REGULAR MEETING, duly posted and noticed, on the 28th day of April 2026, at which meeting a quorum was present.

Robert L. Lozano, Chairman

Michael J. Williamson, Secretary/Treasurer

EXHIBIT A
AGREEMENT
BETWEEN
AEP TEXAS INC.
AND
HIDALGO COUNTY REGIONAL MOBILITY
AUTHORITY FOR
INSTALLATION OF ELECTRICAL DISTRIBUTION
FACILITIES FOR THE
365 TOLLWAY
PROJECT

AEP Texas

Contribution-In-Aid-Of-Construction Agreement
For Electric Distribution Service

Hidalgo County Regional Mobility Auth
Service: 499 W HIGH LINE RD
PHARR, TX

Mailing: 203 W Park Ave P.O. Box 1766
Pharr, TX 78577-4742

Contract #: DWMS00000648730 Work Request #: 91614423

Date: 4/10/2026

You, Hidalgo County Regional Mobility Auth (Customer) have requested AEP Texas (Company) to install/construct certain electric distribution facilities (hereinafter referred to as "Facilities") as follows:AEP to adjust and extend distribution line to feed HCRMA SH 365 Toll illumination and TMS services

The cost for construction/installation of the requested Facilities will be in excess of what would normally be provided by Company at no additional cost to the Customer to initiate service. In accordance with the Company's approved Tariff, as filed with the Public Utilities Commission of Texas, the Customer agrees to pay Company a one-time, non-refundable, Contribution-In-Aid-Of-Construction (CIAC) in the amount of 58,737.55. The Customer understands that he/she receives no ownership or control of the Facilities by virtue of the payment of the CIAC. The Facilities installed by the Company will remain the property of the Company. The Company expressly retains the right to use said Facilities for any purpose which Company deems appropriate under good utility practices, including the distribution of electric service to other customers.

Company agrees to install all AEP facilities, and the Customer agrees to provide CIAC payment of \$58,737.55 and to be ready to take electric service on or before 07/13/2026.

It is understood and agreed that the Company will not begin construction/installation of the Facilities until full payment of the CIAC has been received by the Company; therefore, Customer understands and agrees that he/she needs to make full payment of the CIAC in sufficient time to allow for the construction/installation to be completed by the In Service Date.

The pricing of the CIAC quoted herein is based on the specifics of the Customer's request, including the Customer's stated In Service Date, and must be accepted by the Customer by executing and returning to the Company this Agreement by 7/9/2026 to remain valid. Should Customer alter the request for facilities, or request a delay in (or is otherwise unable to take service by) the stated In Service Date, the Company reserves the right to update the pricing and require an additional CIAC payment to reflect any increases in cost due to the alteration in requested facilities or the delay in taking service, or both.

Nothing contained herein shall be construed as a waiver or relinquishment by Company of any right it has or may hereafter have to discontinue service for default in the payment of any bill owing or to become owing hereunder or for any reason or cause allowed by law.

By signing and returning this Agreement, Customer understands and accepts the above described terms and conditions.

Customer

Company

By _____

By _____

Signature: _____

Signature: _____

Title: _____

Title: _____

Date: _____

Date: _____

Please send signed agreement to:

American Electric Power
Attn: CIAC Admin Pharr North SC
5700 N Cage Blvd
Pharr, TX 78577-7921

Company No: 211

Bill To:

Hidalgo County Regional Mobility Auth
203 W Park Ave P.O. Box 1766
Pharr, TX 78577-4742

Contract No: DWMS00000648730

Date: 4/10/2026

PRO FORMA

Customer No: 11297775
Purchase Order: 91614423

Description	Quantity	UOM	Init Amt	Net Amount
AEP to adjust and extend distribution line to feed HCRMA SH 365 Toll illumination and TMS services	1.0	EA	58,737.55	58,737.55

Amount Due: 58,737.55

Agreement instructions:

- Step 1:** A signed agreement is required regardless of how payment will be made. Email your signed agreement to your AEP Representative.
- Step 2:** Once the agreement has been processed, your AEP Representative will provide you with an invoice (**this may take 3-5 business days**).
- Step 3:** Follow payment instructions on bottom of invoice or customer payment option handout provided by your AEP representative.

WR: 91614423 -3 PHASE

Easement #: N/A

Reference Location
 Latitude: 26.098214
 Longitude: -98.174351

HIDALGO STA
 4845 CKT
 94SB4845

Remove Location 19
 49114504472293
 45-3
 DS101

Install Location 18
 49114454472260
 55-H1
 DS301-4

Install Location 16
 49114224472104
 55-H2
 DS301-4
DS1014 $\frac{120}{240}$ V 10kVA
 B-Ph
Remove Location 17
 49114214472096
 45-3
 DS101

Install Location 14
 49113924471904
 55-H2
 DS301-4
Remove Location 15
 49113924471899
 45-3
 DS101

Install Location 12
 49113634471705
 55-H2
 DS301-4
Remove Location 13
 49113634471702
 45-3
 DS101

Install Location 10
 49113344471507
 55-H2
 DS301-4
Remove Location 11
 49113344471505
 45-3
 DS101

Install Location 8
 49113044471308
 50-1
 DS316-4
Remove Location 9
 49113054471307
 45-3
 DS160

Install Location 6
 49112994471274
 45-H1
 DS340-4(ARM)
Remove Location 7
 49112994471273
 45-3
 DS101

Install Location 4
 49113414471215
 40-H1
 DS340-4(ARM)
Remove Location 5
 49113424471216
 45-3
 DS101

Existing Location 3
 49113864471132
 45-2
 DS316
DS1014 $\frac{240}{480}$ V 10kVA
 C-Ph
 DS357-Arresters

Existing Location 2
 49113314471140
 45-3
 DS340, DS364

Existing Location 1
 49112714471086
 45-3
 DS340

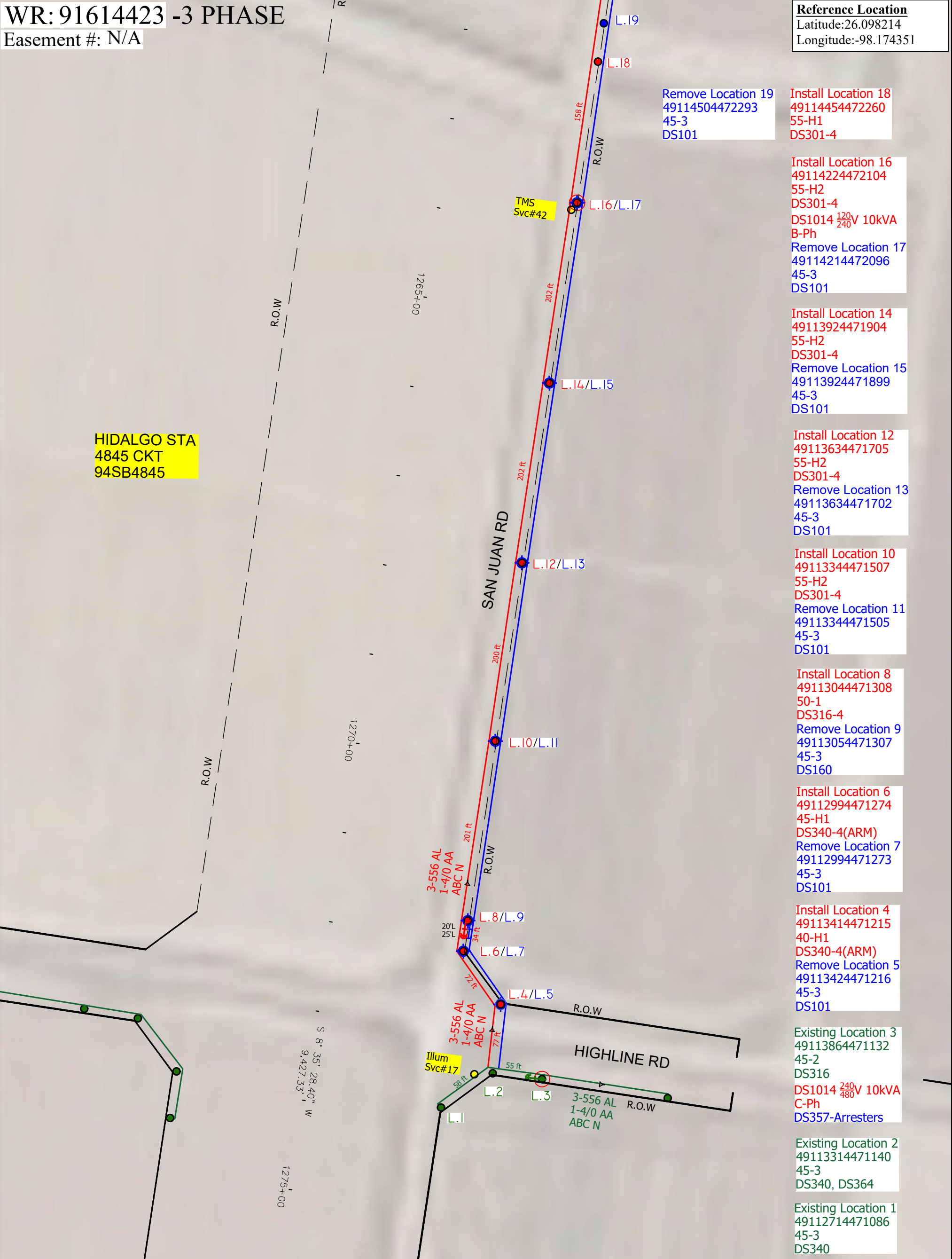

Note to Crew:

- Update each pole ID tag with correct 14 digit GPS location number marked in RED which matches the XY coordinates obtained by GPS
- Blue numbers refer to previous location ID
- Contact TXDOT 48hrs prior to construction
- CONFIRM PHASES & PHASE ROTATION AS NEEDED

Job Description: HCRMA TOLL ROAD - POLE ADJUSTMENTS/SERVICE LOCATIONS - HIGH LINE RD TO LAS MILPAS ROAD		WR: 91614423 -3 PHASE	
Customer: HCRMA - Ramon Navarro IV - (956)-402-4763		Date Completed: 4/13/2026	Man Hours: 344.90
Location: 499 W HIGH LINE RD		County: HIDALGO	Project ID: EDN100039
District: 169 - Pharr	City: PHARR	Crew HQ: 11711	
Station / Circuit: HIDALGO STA / CB4845	N V: 12.47KV	Phases: ABC N	
Drawn By: Homero Quintanilla	Tree Trimming: NO	OWR: N/A	
Tel #: 361-253-4973	Accessible: YES	ESID: N/A	
Issued for:		Scale: 1:100	
		Page: 1-4	

COLOR CODE LEGEND
RED -New Facilities
GREEN-Existing/Transfer Facilities
BLUE -Facilities to Be Removed

Final

Rev. N/A



E ANAYA RD

HIDALGO STA
4845 CKT
94SB4845

Illum
Svc#16

L.35/L.36

TMS
Svc#38

Install Location 35
49116844473884
55-H1
DS301-4
DS1014 ¹²⁰/₂₄₀V 10kVA
B-Phase
Remove Location 34
49116844473884
45-3
DS101

L.33/L.34

Install Location 33
49116584473708
55-H1
DS301-4
Remove Location 34
49116584473707
45-3
DS101

3-556 AL
1-4/0 AA
ABC N

L.32

Install Location 32
49116354473553
55-H1
DS301-4

L.31

Underground Bore
298 ft

TMS
Svc#40

L.30

Remove Location 31
49116244473476
45-3
DS101

L.53

L.54

Install Location 53
49113184473442
40-2
DS163

Install Location 30
49116124473399
55-H2
DS301-4
DS1014 ¹²⁰/₂₄₀V 10kVA
B-Phase

Install Location 54
49113124473403
40-4
DS160
DS1011 ¹²⁰/₂₄₀V 25 kVA
B-Ph

Remove Location 29
49115954473279
45-3
DS101

Install Location 55
49112764473158
40-4
DS101

Install Location 28
49115824473193
55-H2
DS301-4

Install Location 56
49112394472910
40-4
DS101

Remove Location 27
49115664473081
45-3
DS101

Install Location 57
49112034472663
40-4
DS101

Install Location 26
49115524472987
55-H2
DS301-4

Install Location 58
49111674472417
40-4
DS115
DS1012 ¹²⁰/₂₄₀V 10kVA
B-Phase

Remove Location 25
49115374472884
45-3
DS101

Install Location 24
49115224472782
55-H2
DS301-4

Remove Location 23
49115084472687
45-3
DS101

Install Location 22
49114914472575
55-H2
DS301-4
DS1014 ²⁴⁰/₄₈₀V 10kVA
B-Phase

Remove Location 21
49114794472490
45-3
DS101

Install Location 20
49114674472416
55-H2
DS301-4



COLOR CODE LEGEND
RED -New Facilities
GREEN-Existing/Transfer Facilities
BLUE -Facilities to Be Removed



WR: 91614423 -3 PHASE

Install Location 52
49115704475159
40-2
DS163
DS1011 $\frac{120V}{240V}$
10kVA B-Ph

TMS
Svc#37

Install Location 47
49119564475519
50-H2
DS301

Install Location 46
49119224475288
45-H2
DS301

Install Location 45
49118874475056
45-H2
DS340

Install Location 44
49118564475050
45-H2
DS340

Install Location 43
49118514475016
45-1
DS316
UG crossing

Install Location 42
49118144474764
45-H2
DS301-2
DS1014 $\frac{240V}{480V}$ 10kVA
B-Phase

Install Location 41
49117854474571
45-H2
DS301-2

Install Location 40
49117574474379
50-H2
DS301-2

Install Location 39
49117284474186
55-H2
DS301-2

Remove Location 38
49117014473997
45-3
DS115
25kVA $\frac{120V}{240V}$ Xfmr

Install Location 37
49116974473973
55-H1
DS301-4
DS1014 $\frac{240V}{480V}$ 10kVA
B-Phase

HIDALGO STA
4845 CKT
94SB4845

SAN JUAN

COLOR CODE LEGEND	
RED	-New Facilities
GREEN	-Existing/Transfer Facilities
BLUE	-Facilities to Be Removed



WR: 91614423 -3 PHASE

LAS MILPAS RD

Illum
Svc#11

Install Location 51
49120444476119
45-2
DS315

Install Location 50
49120404476089
45-H2
DS316

SAN JUAN

R.O.W

HIDALGO STA
4845 CKT
94SB4845

L.51

L.50

L.49

Install Location 49
49120204475953
50-H2
DS301

1225+00

Install Location 48
49119954475785
50-H2
DS301

L.48

INTERNATIONAL WAY

SAN JUAN

3-556 AL
1-4/0 AA
ABC N

DRAIN DITCH



COLOR CODE LEGEND

- RED** -New Facilities
- GREEN**-Existing/Transfer Facilities
- BLUE** -Facilities to Be Removed



Item 4G

HIDALGO COUNTY REGIONAL MOBILITY AUTHORITY

AGENDA RECOMMENDATION FORM

BOARD OF DIRECTORS	<u> X </u>	AGENDA ITEM	<u> 4G </u>
PLANNING COMMITTEE	<u> </u>	DATE SUBMITTED	<u> 4/20/2026 </u>
FINANCE COMMITTEE	<u> </u>	MEETING DATE	<u> 4/28/2026 </u>
TECHNICAL COMMITTEE	<u> </u>		

1. Agenda Item: **RESOLUTION 2026-43 – CONSIDERATION AND APPROVAL OF SUPPLEMENTAL NUMBER 2 TO WORK AUTHORIZATION NUMBER 1 TO THE PROFESSIONAL SERVICE AGREEMENT WITH ALLIANCE GEOTECHNICAL GROUP, INC. TO PROVIDE DRILL SHAFT TESTING AS PART OF THE 365 TOLLWAY PROJECT.**

2. Nature of Request: (Brief Overview) Attachments: X Yes No
Resolution 2026-43 for SWA No.1 to WA 1 with Alliance Geotechnical Group, Inc.

3. Policy Implication: Board Policy, Local Government Code, Texas Government Code, Texas Transportation Code, TxDOT Policy

4. Budgeted: Yes No X N/A

5. Staff Recommendation: **Motion to approve Resolution 2026-43 – Consideration and approval of Supplemental Number 2 to Work Authorization Number 1 to the Professional Services Agreement with Alliance Geotechnical Group, Inc., to provide drill shaft testing as part of the 365 Tollway Project, as presented.**

6. Program Manager’s Recommendation: Approved Disapproved X None

7. Planning Committee’s Recommendation: Approved Disapproved X None

8. Board Attorney’s Recommendation: Approved Disapproved X None

9. Chief Auditor’s Recommendation: Approved Disapproved X None

10. Chief Financial Officer’s Recommendation: Approved Disapproved X None

10. Chief Development Engineer’s Recommendation: Approved Disapproved X None

11. Chief Construction Engineer’s Recommendation: X Approved Disapproved None

12. Executive Director’s Recommendation: X Approved Disapproved None

THIS ITEM WILL BE
SENT UNDER
SEPERATE COVER

This Page
Intentionally
Left Blank

Item 4H

HIDALGO COUNTY REGIONAL MOBILITY AUTHORITY

AGENDA RECOMMENDATION FORM

BOARD OF DIRECTORS	<u> X </u>	AGENDA ITEM	<u> 4H </u>
PLANNING COMMITTEE	<u> </u>	DATE SUBMITTED	<u> 4/20/2026 </u>
FINANCE COMMITTEE	<u> </u>	MEETING DATE	<u> 4/28/2026 </u>
TECHNICAL COMMITTEE	<u> </u>		

1. Agenda Item: **RESOLUTION 2026-44 – CONSIDERATION AND APPROVAL OF CONTRACT AMENDMENT 2 TO THE PROFESSIONAL SERVICE AGREEMENT WITH ALLIANCE GEOTECHNICAL GROUP, INC. TO INCREASE MAXIMUM PAYABLE AMOUNT FOR SUPPLEMENTAL NUBMER 2 TO WORK AUTHORIZATION NUMBER 1.**

2. Nature of Request: (Brief Overview) Attachments: X Yes No
Resolution 2026-44 for CA No.1 to PSA with Alliance Geotechnical Group, Inc.

3. Policy Implication: Board Policy, Local Government Code, Texas Government Code, Texas Transportation Code, TxDOT Policy

4. Budgeted: Yes No X N/A

5. Staff Recommendation: **Motion to approve Resolution 2026-44 – Consideration and approval of Contract Amendment Number 2 to the Professional Services Agreement with Alliance Geotechnial Group, Inc., to increase the maximum payable amount for Supplemental Number 2 to Work Authorization Number 1, as presented.**

6. Program Manager’s Recommendation: Approved Disapproved X None

7. Planning Committee’s Recommendation: Approved Disapproved X None

8. Board Attorney’s Recommendation: Approved Disapproved X None

9. Chief Auditor’s Recommendation: Approved Disapproved X None

10. Chief Financial Officer’s Recommendation: Approved Disapproved X None

10. Chief Development Engineer’s Recommendation: Approved Disapproved X None

11. Chief Construction Engineer’s Recommendation: X Approved Disapproved None

12. Executive Director’s Recommendation: X Approved Disapproved None

THIS ITEM WILL BE
SENT UNDER
SEPERATE COVER

This Page
Intentionally
Left Blank

Item 41

HIDALGO COUNTY REGIONAL MOBILITY AUTHORITY

AGENDA RECOMMENDATION FORM

BOARD OF DIRECTORS	<u> X </u>	AGENDA ITEM	<u> 4I </u>
PLANNING COMMITTEE	<u> </u>	DATE SUBMITTED	<u> 4/21/2026 </u>
FINANCE COMMITTEE	<u> </u>	MEETING DATE	<u> 4/28/2026 </u>
TECHNICAL COMMITTEE	<u> </u>		

1. Agenda Item: **RESOLUTION 2026-48 – CONSIDERATION AND APPROVAL OF CHANGE ORDER NUMBER 22 TO THAT CERTAIN CONTRACT WITH PULICE CONSTRUCTION, INC. FOR THE 365 TOLLWAY CONSTRUCTION PROJECT.**

2. Nature of Request: (Brief Overview) Attachments: Yes No
Approval of Resolution 2026-48 for CO No. 22.

3. Policy Implication: Board Policy, Local Government Code, Texas Government Code, Texas Transportation Code, TxDOT Policy

4. Budgeted: Yes No N/A

5. Staff Recommendation: **Motion to approve Resolution 2026-48 – Consideration and Approval of Change Order Number 22 to that certain contract with Pulice Construction, Inc. for the 365 Tollway Construction Project, as presented.**

6. Program Manager’s Recommendation: Approved Disapproved None

7. Planning Committee’s Recommendation: Approved Disapproved None

8. Board Attorney’s Recommendation: Approved Disapproved None

9. Chief Auditor’s Recommendation: Approved Disapproved None

10. Chief Financial Officer’s Recommendation: Approved Disapproved None

10. Chief Development Engineer’s Recommendation: Approved Disapproved None

11. Chief Construction Engineer’s Recommendation: Approved Disapproved None

12. Executive Director’s Recommendation: Approved Disapproved None



HCRMA
HIDALGO COUNTY REGIONAL MOBILITY AUTHORITY

Memorandum

To: Pilar Rodriguez, PE, Executive Director

From: Ramon Navarro IV, P.E., Chief Construction Engineer

Date: April 21, 2026

Re: **2026-48: CONSIDERATION AND APPROVAL OF REVISED CHANGE ORDERS NUMBER 22 TO THAT CERTAIN CONSTRUCTION CONTRACT WITH PULICE CONSTRUCTION, INC. FOR THE 365 TOLLWAY.**

GOAL

Board's consideration and approval of final negotiated CO#22 for Cast-in -Place 12' walled Type A Well Structures

BACKGROUND

HCRMA, HDR, Pulice Construction Inc. and HCID#2 have been negotiating various items since the implementation of the project. The HCRMA and HCID#2 have agreements in-place requiring concurrences to current plans, specifications, and implemented changes. HCID#2 is demanding immediate cost, scheduling impactive changes throughout project. After proposing various alternatives HCID#2 remains steadfast on implementing desired amendments to plans, specifications, and current agreements at no cost to them.

On December 11, 2024, HCRMA Board approved Resolution 2024-52 authorizing Change Order #14 at maximum cost not to exceed \$492,363.86 for implementation of cast-in-place monolithic junction boxes (CIP) in lieu of precast junction boxes.

On January 17, 2025, Resolution 2025-07 was Board approved. Parties negotiated a cost savings of \$42,927.50. The original scope of CO#14 remained in full effect with assurance of compliance with the standard specifications included within the contract and adding no additional time.

Change Order No. 22

In acknowledgment of the HCRMA \ HCID#2 Joint Use Agreements and upon conducting non-binding mediations. Staff recommends approval of adding items to the contract to compensate Contractor for the construction of 5 cast-in-place irrigation wells [CIP Type A Gate Well Structures (12" walled) with hot galvanized grate tops, page 1207A]. This Change Order accounts for all added components, labor required for installation and compliance in accordance to demanded betterments as agreed to with the Hidalgo County Irrigation District #2. Potential additional time relating to this Change Order will be included in a separate Change Order. The sum of Change Order#22 proves a maximum cost increase of \$374,094.50

RECOMMENDATION

HCRMA \ HDR staff recommend Board's approval and acceptance of CO#22, Resolution 2026-48 authorizing Change Order #22 to that certain construction contract with Pulice Construction Inc. for the 365 Tollway Project. This Change Order accounts for all added components, labor required for installation and compliance in accordance to demanded betterments as agreed to with the Hidalgo County Irrigation District #2 for the addition of 5 cast-in-place irrigation wells [CIP Type A Gate Well Structures (12" walled) with hot galvanized grate tops]. Potential additional time relating to this Change Order will be included in a separate Change Order. The sum of Change Order#22 proves a maximum cost increase of \$374,094.50



Contractor Pulice Construction, Inc.

CONSTRUCTION CONTRACT AMENDMENT SUMMARY

RESOLUTION 2026-48

Original Contract Amount \$ 295,932,420

Change Order No. 22

Amount \$ 374,094.50

Approved Amendments:

Resolution No.	Description	Amount
2021-46	Main Contract	\$ 295,932,420.25
2021-54	CO No. 1 - No NTP until VECP is approved	\$ 0.00
2021-78	CO No. 2 Revised Contract Amount	-\$ 14,208,622.30
2022-36	CO No. 3 Further establish VECP Concepts	\$ 0.00
2023-05	CO No. 4 Remove Drill Shat	\$ 171,516.59
Subtotal from Cont. Page		<u>\$ 7,744,761.36</u>

Contract Amount **\$ 289,640,075.90**

Proposed Amendment

2026-48	CO No. 22 HCID2 Amendments to plans	\$ 374,094.50
---------	-------------------------------------	----------------------

Goal and Options:

Board's consideration and approval of final negotiated CO#22 for Cast-in -Place 12' walled Type A Well Structures.

Staff is recommending approval of this request in the amount of \$ 374,094.50 for a Revised Contract Amount of \$ 290,014,170.40

Ramon Navarro, Const.

Requested by:

Resolution No.	Description	Amount
2023-30	CO No. 5 Adjust VECP Net savings	\$ 4,325,130.78
2024-27	CO No. 6 Compansate for Depot Rad	-\$ 30,843.33
2024-27	CO No. 7 Unanticipated Utility Conflict Mission	\$ 13,075.83
2024-27	CO No. 8 ROW Utility Adjustment FM 494	\$ 20,932.00
2024-27	CO No. 9 Design Traffic Control plan	-\$ 1,782.00
2024-27	CO No. 10 Error-design Traffic Control	\$ 249,919.32
2024-27	CO No. 11 Differing Site Condition Revisions	\$ 23,450.97
2024-27	CO No. 12 Design Error/Inefficiencies add adjust	\$ 135,487.78
2024-27	CO No. 13 Design Error/Inefficiencies ITS pole	\$ 212,599.20
2024-51	CO No. 14 Approved \$492,363.86	\$ 0.00
2025-07	CO No. 14 Revised	\$ 449,436.36
2025-08	CO No. 15 Finalized quantities & unit costs	\$ 150,000.00
2025-55	CO No. 16 Revise Riprap type/increase quantity	\$ 65,012.89
2026-18	CO No. 17 Infused meter switches	\$ 99,430.28
2026-26	CO No. 18 HCIDN bridge Const. items	\$ 1,408,666.85
2026-27	CO No. 19 Tunneling/Extending Irr. improvement	\$ 524,621.53
2026-28	CO No. 20 New Mat. for HCID2 requirements	\$ 77,699.30
2026-31	CO No. 21 Juan Balli Rd and Add. driveways	\$ 21,923.60

Subtotal \$ 7,744,761.36

HIDALGO COUNTY REGIONAL MOBILITY AUTHORITY
BOARD RESOLUTION No. 2026-48

**CONSIDERATION AND APPROVAL OF CHANGE ORDER NUMBER TWENTY-TWO (22)
TO THAT CERTAIN CONTRACT WITH PULICE CONSTRUCTION, INC. FOR
THE 365 TOLLWAY**

THIS RESOLUTION is adopted this 28th day of April 2026 by the Board of Directors of the Hidalgo County Regional Mobility Authority at a regular meeting.

WHEREAS, the Hidalgo County Regional Mobility Authority (the "Authority"), acting through its Board of Directors (the "Board"), is a regional mobility authority created pursuant to Chapter 370, Texas Transportation Code, as amended (the "Act"); and

WHEREAS, on November 17, 2005, the Texas Transportation Commission (the "Commission") created the Authority pursuant to (i) the Act; (ii) Title 43, Texas Administrative Code; (iii) a petition of the Hidalgo County Commissioners Court (the "County"); and (iv) findings by the Commission that the creation of the Authority would result in certain direct benefits to the State of Texas (the "State"), local governments, and the traveling public and would improve the State's transportation system; and

WHEREAS, the Act allows the Authority to construct transportation projects within the County, including the 365 Tollway Project (the "Project"); and

WHEREAS, the Texas Department of Transportation approved the Project's final design, contract letting and award procedures, and form of construction contract, including a post-award value engineering change proposal process; and

WHEREAS, on August 8, 2021, August 11, 2021, August 15, 2021, August 18, 2021, August 22, 2021, and August 25, 2021, the Authority published a solicitation for Bid #2021-00 I for the 365 Toi Iway Project (Segments I and 2), Contract No. 0921-02-368 for the Project; and

WHEREAS, bids for the Project were submitted electronically via Civcast Bid System; the first bid was received at 2:27 p.m. on October 13, 2021, and the last bid was received at 2:51 pm on October 13, 2021; and

WHEREAS, at 3:05 p.m. on October 13, 2021, the Authority opened and read into the record three (3) formal sealed, electronic bids for the Project from: (i) Pulice Construction, Inc., (ii) Webber, LLC., and Anderson Columbia Co., Inc., in amounts ranging from \$295,932,420.25 to \$340,409,415.64 for construction of the Project; and

WHEREAS, Pulice Construction, Inc. provided the lowest Project bid in the amount of \$295,932,420.25; and

WHEREAS, on October 19, 2021, the Board approved Resolution 2021-46 conditionally awarding the construction contract of the 365 Toll Project to the lowest, responsive, and responsible bidder Pulice Construction, Inc. in the amount of \$295,932,420.25; and

WHEREAS, on November 10, 2021, the Board approved Resolution 2021-54, approving Change Order Number One (1) to the construction contract with Pulice Construction Inc.; provided, there was no issuance of an NTP to Pulice Construction Inc. until a Value Engineering Proposal ("VECP") was approved by the Board of Directors and TxDOT to establish the financing for the Project. If, after the VECP process, the Project scope was not deemed feasible and additional revenue was not available to fully fund the Project, no NTP would be issued and the Authority would have terminated the contract without incurring any additional costs other than those approved under Change Order Number One. The VECP is structured to identify concepts and function-oriented techniques to improve the value of the Project, or any component thereof, including improvements to schedule, operating costs, constructability, and risk mitigation; without altering scope or environmental justices; and

WHEREAS, on December 20, 2021, the Authority approved Resolution 2021-78, authorizing the YECP proposals outlined in Exhibit A to Change Order Number Two (2) and the revising the contract amount to \$281,723,797.95; and, the Authority also authorized a contingency fund for the Project in the amount of \$5,000,000, and established a total overall Project cost of \$286,723,797.95; and

WHEREAS, the Authority and the Board amended the Contract through Amendment No. I to capture the risk allocations and make other Contract clarifications in support of YECP; and

WHEREAS on April 19, 2022, the Authority approved Resolution 2022-36, consideration and approval of Change Order Number Three (3) to that certain construction contract with Pulice Construction Inc. for the 365 Tollway Project, in order to further establish the VECP concepts and supporting details as provided in Exhibit A hereto; and

WHEREAS on November 4, 2021, Pulice Construction Inc, expressed concern on Engineer of Record's scour reports and calculated foundation loads. Upon discussions, data collection and research, November 16, 2022, the HCRMA requested HDR[GEC] provide investigative recommendations; and

WHEREAS on December 7, 2022, HOR provided review and supporting documentation in upsizing particular bent foundations at PCI proposal and costs; and

WHEREAS, on January 24, 2023, the Authority approved Resolution 2023- 05, Change Order Number Four (4) to the construction contract with Pulice Construction Inc. for the net cost increase of \$171,516.59, by removal of 1,524LF of Drill Shaft (42") and introducing 48" drill shafts to incorporate detailed, finalized quantities and unit costs; and establishes State/Federal participation on modified unit costs, assuring compliance with the standard specifications included within the contract; and

WHEREAS, on July 25, 2023, the HCRMA Board approved Resolution 2023- 30, Change Order Number Five (5) to that certain construction contract with Pulice Construction Inc. for the 365 Tollway Project, Change Order Number 5 provides a net cost increase of \$4,325,130.78 to be fully paid by HCRMA [Owner]. Establishing a new revised contract price of \$286,220,445.32 with no additional time; and, incorporates detailed, finalized quantities and unit costs; and establishes State/Federal participation on modified unit costs, assuring compliance with the standard specifications included within the contract; and

WHEREAS, on July 9, 2024, the Board's approved Resolution 2024-27, for authorization of Change Orders Number Six (6) through thirteen (13) to that certain construction contract with Pulice Construction Inc. for the 365 Tollway Project. The sum of Change Orders proves a net cost increase of \$832,561.77 to be fully paid by HCRMA [Owner]. Establishing a new revised contract price of \$287,053,007.09 with no additional time; and, incorporates detailed, finalized quantities and unit costs; and establishes State/Federal participation on modified unit costs, assuring compliance with the standard specifications included within the contract. Attached exhibits provide current assessment and breakdown; and

WHEREAS, on December 17, 2024 the Authority approved Resolution 2024-52, for authorization of Change Order Number Fourteen (14) to that certain construction contract with Pulice Construction Inc. for the 365 Tollway Project. The sum of Change Orders proves a maximum cost increase of \$492,363.86 to be fully paid by HCRMA [Owner]. Establishing a new revised contract price of \$287,335,648.95 with no additional time; and, incorporates detailed, finalized quantities and unit costs; and establishes no State/Federal participation on modified unit costs, assuring compliance with the standard specifications included within the contract. Attached exhibits provide current assessment and breakdown; and

WHEREAS, on January 24, 2025 the Authority approved Resolution 2025-07, for authorization of the Revised Change Order Number Fourteen (14) to that certain construction contract with Pulice Construction Inc. for the 365 Tollway Project. The sum of Change Order# 14 proves a maximum cost increase of \$449,436.36; and

WHEREAS, on January 24, 2025, the Authority approved Resolution 2025-08, for authorization for Change Order Number Fifteen (15) to that certain construction contract with Pulice Construction Inc. for the 365 Tollway Project. The sum of Change Order Number Fifteen increases cost by \$150,000; and to be fully paid by HCRMA [Owner]. Establishing a new revised contract price of \$287,442,721.45 with no additional time; and, incorporates detailed, finalized quantities and unit costs; and establishes no State/ Federal participation on modified unit costs, assuring compliance with the standard specifications included within the contract. Attached exhibits provide current assessment and breakdown; and

WHEREAS, on August 26, 2025 the Authority considered and approved Resolution 2025-55, for authorization of Change Order Number Sixteen (16) to that certain construction contract with Pulice Construction Inc. for the 365 Tollway Project. CO revises riprap type to stone TY "R" and increases quantity to 196 CY. The sum of Change Order#16 proves a maximum cost increase of \$65,012.89; and

WHEREAS, on January 27, 2026 the Authority approved Resolution 2026-18, for authorization of Change Order Number Seventeen (17) to that certain construction contract with Pulice Construction Inc. for the 365 Tollway Project. CO adds a new line item to contract to compensate Contractor for the addition of thirty-two (32) unfused switch boxes, all added components, and labor required for installation and compliance. Additional time request was mentioned but never formally submitted. The sum of Change Order #17 proves a maximum cost increase of \$99,430.28; and

WHEREAS, on February 24, 2026 the Authority approved Resolution 2026-26, for authorization of Change Order Number Eighteen (18) to that certain construction contract with Pulice Construction Inc. for the 365 Tollway Project. CO adds new line items to the contract to compensate Contractor for the construction and removal of sheet piling cofferdams within the San Juan Main Canal, as agreed to with the Hidalgo County Irrigation District #2. This Change Order accounts for all added components, and labor required for installation and compliance. Potential additional time relating to this Change Order will be included in a separate Change Order. The sum of Change Order# I 8 proves a maximum cost increase of \$1,408,666.85; and

WHEREAS, on February 24, 2026 the Authority approved Resolution 2026-27, for authorization of Change Order Number Nineteen (19) to that certain construction contract with Pulice Construction Inc. for the 365 Tollway Project. CO adds new line items to the contract to compensate Contractor for the tunneling of 72" RCLHPP (CL V) (ASTM C36 I C-25) and extend proposed irrigation improvements at STY A I051+00, as agreed to with the Hidalgo County Irrigation District #2. This Change Order accounts for all added components, and labor required for installation and compliance. Potential additional time relating to this Change Order will be included in a separate Change Order. The sum of Change Order# 19 proves a maximum cost increase of \$524,621.53; and

WHEREAS, on February 24, 2026, the Authority approved Resolution 2026-28, for authorization of Change Order Number Twenty (20) to that certain construction contract with Pulice Construction Inc. for the 365 Tollway Project. CO removes existing line items and adds new line items to the contract to compensate Contractor for acquiring material required pertaining to Hidalgo County Irrigation District #2's irrigation crossings. HCID #2 required irrigation slide gates to be fabricated of specific steel components, additional requirements than what was in the original contract bid items. This Change Order accounts for all new material needed to adhere to HCID #2 's requirements and all labor and equipment necessary to install the new hardware. Potential additional time relating to this Change Order will be included in a separate Change Order. The sum of Change Order #20 proves a maximum cost increase not to exceed \$77,699.30; and

WHEREAS, on March 24, 2026 the Authority approved Resolution 2026-31, for authorization of Change Order Number Twenty-one (21) to that certain construction contract with Pulice Construction Inc. for the 365 Tollway Project. CO introduces a line item to the contract to compensate Contractor for the addition of a concrete driveway that was added to accommodate the city of McAllen's infrastructure along the Anzalduas Connector. The sum of Change Order #21 proves a maximum cost increase of \$21,923.60; and

WHEREAS, the Authority finds it necessary to consider for approval Resolution 2026-48, for authorization of Change Order Number twenty-two (22) to that certain construction contract with Pulice Construction Inc. for the 365 Tollway Project. CO adds new line items to the contract to compensate Contractor for the construction of eight (8) cast-in-place irrigation wells [CIP Type A (12" walled) with hot galvanized grate tops]. This Change Order accounts for all added components, labor required for installation and compliance in accordance to demanded betterments as agreed to with the Hidalgo County Irrigation District #2. Potential additional time relating to this Change Order will be included in a separate Change Order. The sum of Change Order#22 proves a maximum cost increase of \$374,094.50; and

NOW THEREFORE BE IT RESOLVED BY THE BOARD OF DIRECTORS
OF THE HIDALGO COUNTY REGIONAL MOBILITY AUTHORITY THAT:

Section 1. The recital clauses are incorporated in the text of this Resolution
as is fully restated.

Section 2. The Board hereby approves Change Orders Number Twenty-Two
(22) to the construction contract with Pulice Construction Inc. for the net cost
increase of \$374,094.50 for the inclusion of five (5) additional irrigation
well structures (Type A) within the project.

Section 3. Construction of the 365 Toll Project in substantially final form
as hereto detailed, revising and establishing a unit bid construction amount of
\$269,076,454.88 and an overall contract amount of \$290,014,170.38.

Section 4. Upon final acceptance from FHW A/TxDOT and HCRMA Legal's review
of final form; The Board hereby authorizes the Executive Director to execute
Change Order Number Twenty-two.

PASSED AND APPROVED AS TO BE EFFECTIVE IMMEDIATELY BY THE BOARD OF DIRECTORS OF THE HIDALGO COUNTY REGIONAL MOBILITY AUTHORITY AT A REGULAR MEETING, duly posted and noticed, on the 28th day of April 2026, at which meeting a quorum was present.

Robert L. Lozano, Chairman

Micheal Williamson, Secretary/Treasurer

INSTRUCTIONS FOR PREPARING THE CHANGE ORDER

The following information is provided to assist the LG in preparing a Change Order (CO). Early coordination with TxDOT prior to Contractor signature is strongly encouraged.

- 1 Populate the appropriate header information, including the Contractor's name as it appears in the contract.
- 2 Insert the work limits for the Change Order.
- 3 Give a narrative of the revised work being authorized in the Change Order.

Include a statement to address time by one of the following methods:

- 1) Add the time extension number and time in the line provided.
- 2) State in the narrative that no time is added by this CO.

If a time extension is included in the CO, include the appropriate details, and attach the Time Impact Analysis to support the additional days.

Provide the total value of the amount being added to the contract by the Change Order.

- 4 Attach any new/revised plan sheet(s).
- 5 Direct the contractor to sign in the contractor's signature block.

Affix the seal of the authorized local representative in the space located at the left corner of the bottom of the CO Form. Adhere to Change Order Approval Policy of local agency.

Provide the completed form and all supporting documents to TxDOT for review and concurrence. TxDOT will utilize the review checklist at the end of this form to provide its written response.

- 1 Populate the appropriate header information.
- 2 Identify the date in which the Change Order was received by TxDOT for review, and whether appropriate and/or adequate information was provided to support the elements of the Change Order.
- 3 Document TxDOT's decision of whether the costs/time extension associated with the Change Order are determined to be participating. If any element is deemed non-participating, provide a comment to explain the determination.

CONSTRUCTION CONTRACT CHANGE ORDER NUMBER: 22

1. Contract Information

LG Contract No:	<u>0921-02-368</u>	County:	<u>Hidalgo</u>
CCSJ:	<u>0921-02-368</u>	District:	<u>Pharr</u>
Project No:	<u>DMO 2013(420)</u>	Highway:	<u>365 Tollway</u>
Contractor:	<u>Pulice Construction Inc.</u>		

2. Change Order Work Limits: Station 1084+00 to Station 1107+00

3. Describe the change(s) and the reason for the Change Order. When necessary, include exceptions to this agreement.

(4A) 3RD PARTY FAILURE COMMT HCRMA, HDR, Pulice Construction Inc. and HCID#2 have been negotiating various items since the implementation of the project. The HCRMA and HCID#2 have agreements in-place requiring concurrences to current plans, specifications, and implemented changes. HCID#2 is demanding immediate cost impactive changes and impacts to schedule throughout project. After proposing various alternatives HCID#2 remains steadfast on implementing desired amendments to plans.

Time Ext. #: N/A # of Days Added: N/A Time Impact Analysis attached: (Yes/No): N/A

Amount added by this Change Order: \$374,094.50

4. New or revised plan sheet(s) attached: 1195-1198; 1215-1217

5. Change Order Authorizations: Each signatory hereby warrants that each has the authority to execute this Change Order.

Contractor acknowledges that the compensation and time adjustment set forth in this Change Order constitute full and final payment and adjustment for the Work described herein, including all costs and impacts directly attributable to such Work, to the extent known or reasonably foreseeable as of the date of execution of this Change Order. Contractor reserves, and does not waive, the right to seek an equitable adjustment solely for demonstrable impacts, if any, that are not reasonably known or foreseeable as of the date of execution and that are directly and exclusively caused by the changes described in this Change Order, provided that Contractor complies with all applicable notice and claim requirements of the Contract. To the extent compensable delay days and time related overhead associated with the San Juan Canal project that is the subject of this Change Order are determined to be due to the Contractor as part of any overall project delay, such days and overhead will be established as part of the broader project time impact analysis. Except as expressly set forth above, Contractor waives any and all claims for additional compensation, time, or damages arising out of or relating to the Work covered by this Change Order.

THE CONTRACTOR

Signature: _____ Date: _____
 Typed/Printed Name: _____
 Typed/Printed Title: _____

THE OWNER

Recommended for Execution:

Approved:

Ramon Navarro, IV, PE, HCRMA Chief Construction Engineer

Pilar Rodriguez, HCRMA Executive Director

Signature/Title _____ Date: 4/21/2026

Signature /Title _____ Date: 4/28/2026

Signature /Title _____ Date: _____

Signature /Title _____ Date: _____

Signature /Title _____ Date: _____

Signature _____ Date: _____

Signature /Title _____ Date: _____

Signature /Title _____ Date: _____

Engineer's Seal:

CONSTRUCTION CONTRACT CHANGE ORDER NUMBER: 21

CCSJ: 0921-02-368

TABLE A: Force Account Work

LABOR	HOURLY RATE	EQUIPMENT	HOURLY RATE

TABLE B1: Contract Items

ITEM	DESCRIPTION	UNIT	UNIT PRICE (P)	ORIGINAL + PREVIOUSLY REVISED		NEW		VARIANCE (%)
				QUANTITY (Q1)	ITEM COST (PxQ1)	QUANTITY (Q2)	ITEM COST (PxQ2)	OVERRUN/ UNDERRUN
0465-9001	JCTBOX(CIP)(20FT-25FT)(8FTX8FT)	EA	\$ 99,942.79	2	\$199,885.58	0	0	(\$199,885.58)
0465-9002	JCTBOX(CIP)(10FT-15FT)(8FTX8FT)	EA	\$53,509.96	3	\$160,529.88	1.0	\$53,509.96	(\$107,019.92)
0465-9006	JCTBOX(Material Remove/Disposal)	EA	\$6,000.00	0	0	1	\$6,000.00	\$6,000.00
1007-9005	IRRIGATION WELL (TYPE A-CIP 12' WALL)	EA	\$135,000	3	\$405,000.00	8	\$1,080,000.00	\$675,000.00
Sub-total:							\$374,094.50	

Change Order #21 TxDOT Review

1. Contract Information

LG Contract No:	<u>0921-02-368</u>	County:	<u>Hidalgo</u>
CCSJ:	<u>0921-02-368</u>	District:	<u>Pharr</u>
Project No:	<u>DMO 2013(420)</u>	Highway:	<u>365 Tollway</u>
Contractor:	<u>Pulice Construction Inc.</u>		

2. Change Order Details

[LGP Guide 9.3.2](#)

Date Received: 4/22/26

Did the LG provide an adequate narrative describing the change(s) and the reason for the CO?

Yes No N/A

Did the LG provide adequate documentation to support the elements of the CO?

- New/revised plan sheets for design changes?

Yes No N/A

- Cost analysis for any new contract items?

Yes No N/A

Total amount of Change Order: \$ 374,094.50

- Time impact analysis for additional contract days?

Yes No N/A

Additional days included in this change order: N/A

3. Participation Determination*

Are the costs associated with this CO eligible for participation?

Yes No N/A

Note: Eligibility of costs does not guarantee availability of federal or state funds; refer to AFA for responsibility of cost overruns. Actual participation will be determined by the final project cost reconciliation.

Current Contract Value: _____

Amount added by this Change Order: _____

Total Amount of Revised Contract Value: _____

Is the time extension associated with this CO eligible for participation?

Yes No N/A

Current number of contract days: _____

Number of eligible days added by this CO: _____

Total number of approved contract days: _____

*Comments:

Reviewed by: _____

Signature/Title

Date: _____

CHANGE ORDER PROPOSAL

October 28, 2025

DCN: Pulice-HCRMA-121

TO: Ramon Navarro, P.E., C.F.M.
Chief Construction Engineer
HC Regional Mobility Authority
203 W. Newcombe Avenue
Pharr, TX 78577

FROM: Rafael Carmona
Project Manager
Pulice Construction Inc.
7902 S. 10th Street,
McAllen, TX 78503

RE: 365 Toll Project (Seg 1 & 2) – Irrigation Structures at Cage

SCOPE: The scope of this change is to adjust items related to the Irrigation structures at Cage.

CHANGE JUSTIFICATION: Per revised drawings (10/01/2025), the CIP Junction Boxes at Cage will be replaced by Irrigation Well Type A structures per sheet 1207.

SPECIFICATIONS, PLANS OR OTHER DOCUMENTS REQUIRED: Sheet 1207

CHANGE TO CONTRACT PRICE: We're requesting additional compensation for these changes as detailed below.

Item	Description	Unit	Unit Price	Current Qty	CO Qty	Revised Qty	CO Amount
0465-9001	JCTBOX(CIP)(20FT-25FT)(8FTX8FT)	EA	\$ 99,942.79	2	-2	0	\$ (199,885.58)
0465-9002	JCTBOX(CIP)(10FT-15FT)(8FTX8FT)	EA	\$ 53,509.96	3	-2	1	\$ (107,019.92)
0465-9006	JCTBOX(Material Remove/Disposal)	EA	\$ 6,000.00	0	1	7	\$ 36,000.00
1007-9005	IRRIGATION WELL (TYPE A)	EA	\$ 135,000.00	3	5	8	\$ 675,000.00

Item 465-9006 item of 1 not 7. therefore \$6K^{\$} 374,094.50

CHANGE TO CONTRACT TIME: Pulice will evaluate according to HCRMA's specifications guidelines and will submit to the HCRMA a request for added time once it is known.

If you have any questions or need additional information, please contact me at (346) 324-0781.

Sincerely,



Rafael Carmona
Project Manager
Pulice Construction Inc.

EFFECTIVE PLAN SHEET - RELEASED FOR CONSTRUCTION; DATE 02/20/2026
 THIS SHEET HAS BEEN MODIFIED DURING CONSTRUCTION AS A RESULT OF A REQUEST FOR INFORMATION (RFI), FIELD CHANGE, OR CHANGE ORDER. THIS SHEET MODIFICATION IS INDEPENDENT OF DESIGN CHANGES FROM THE VECP PROCESS. THIS MODIFIED SHEET IS RELEASED FOR CONSTRUCTION.

DATE: 2/20/2026 10:51:51 AM
 FILE: c:\projectwise\dannenbaum-hcrma\workdir\copy of michael.meroney\dms77126\hcrwid3\irrigdet_3.dgn

GENERAL NOTES

1. CHAMFER ALL EXPOSED CONC. CORNERS 1".
2. ALL CONCRETE SHALL HAVE A COMPRESSIVE STRENGTH OF 4000 P.S.I. AT 28 DAYS
3. ALL REINFORCING STEEL SHALL BE GRADE 60
4. LAP OR ANCHOR ALL STEEL A MINIMUM OF 30 DIA.'S. ALL HORZ. STEEL SHALL BE CONTINUOUS AROUND CORNERS.
5. REINFORCING BARS MAY BE ADJUSTED BUT SHALL PROVIDE A MINIMUM OF 2 INCHES CLEAR COVER
6. *PROP. SLUCIE GATE SHALL BE A FRESNO LIFT AND GATE (SQUARE) ® OR APPROVED EQUAL DESIGNED FOR 20' SEATED AND UNSEATED HEADS
 GATE SHALL HAVE 316 STAINLESS STEEL SIDE ANGLES (FRAME), 316 STAINLESS STEEL STEM, GEARED LIFT, PACKING GLAND, & PEDISTAL MADE OF CAST IRON.
7. PROP. GALVANIZED FRAME AND GRATE SHALL BE SUBSIDIARY TO CIP JUNCTION BOX (12")

TABLE A:

JUNCTION BOX NO.	TOP ELEV.	FLOWLINE ELEV.
①	110.50	83.90
②	110.30	83.84
③*	98.50	83.76
④	98.00	83.49
⑤*	98.00	83.25

* ONLY JUNCTION BOXES ③ AND ⑤ INCLUDE 15" SLUICE GATE

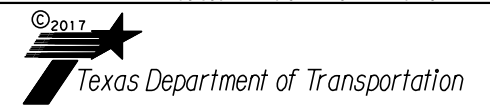
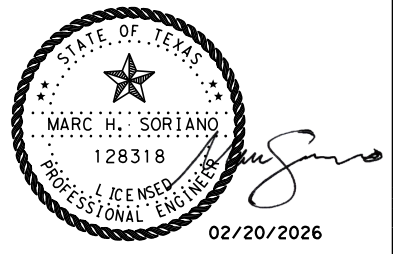
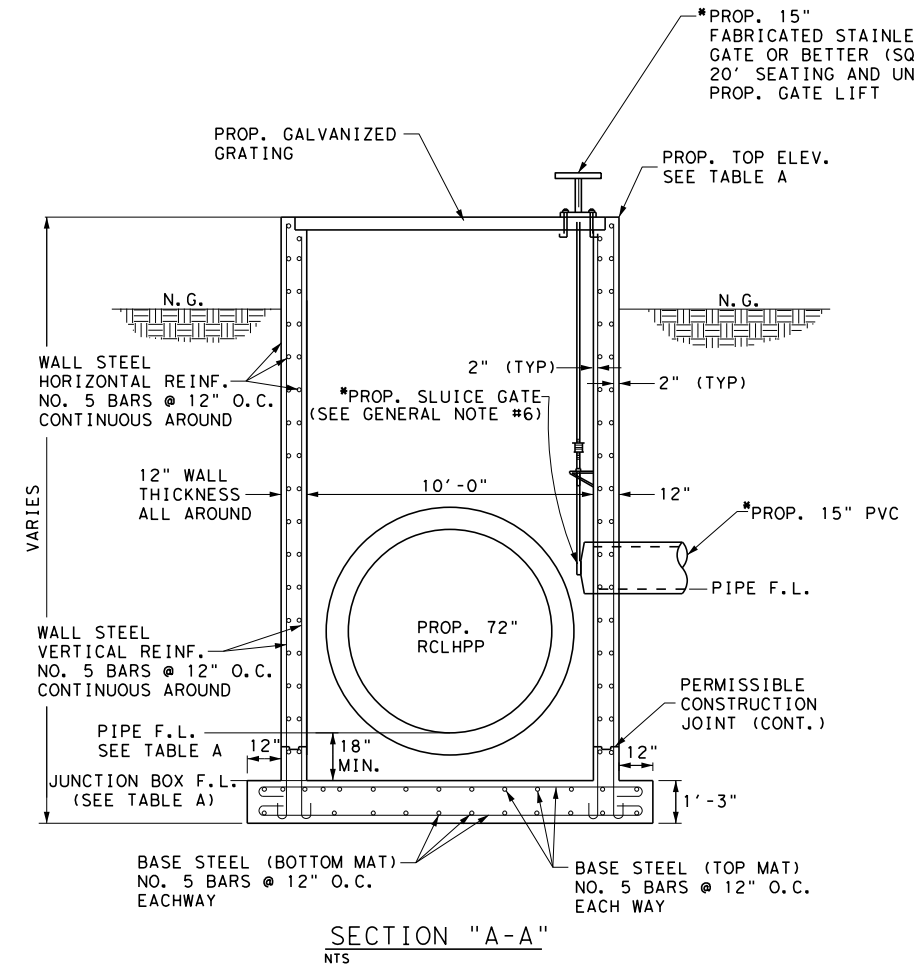
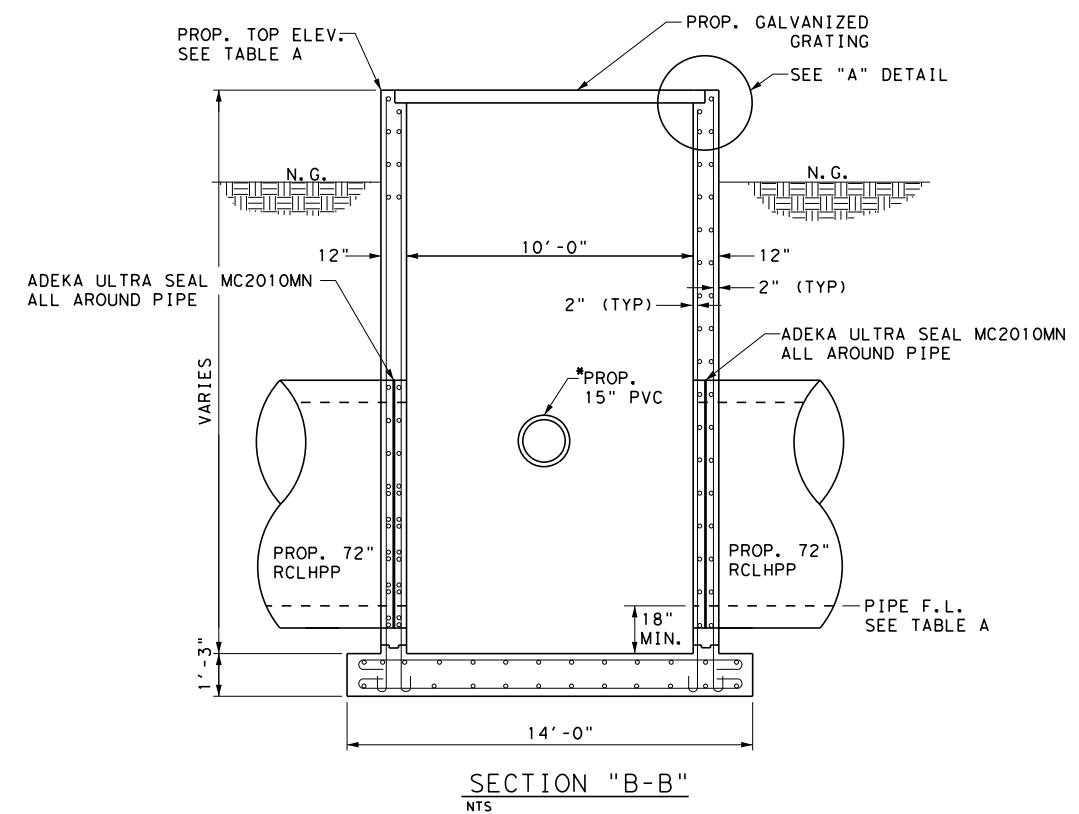
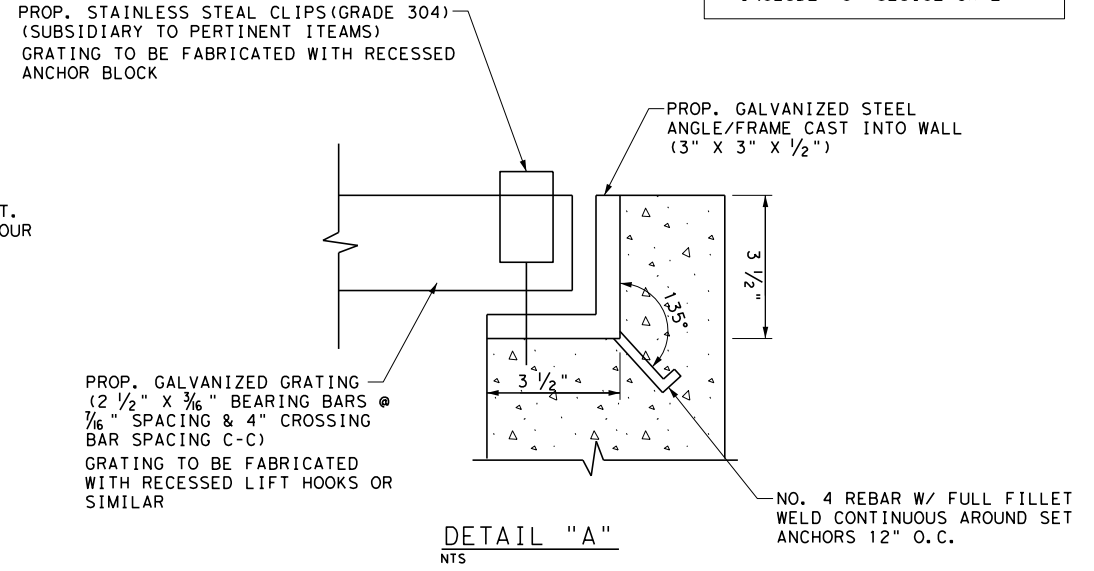
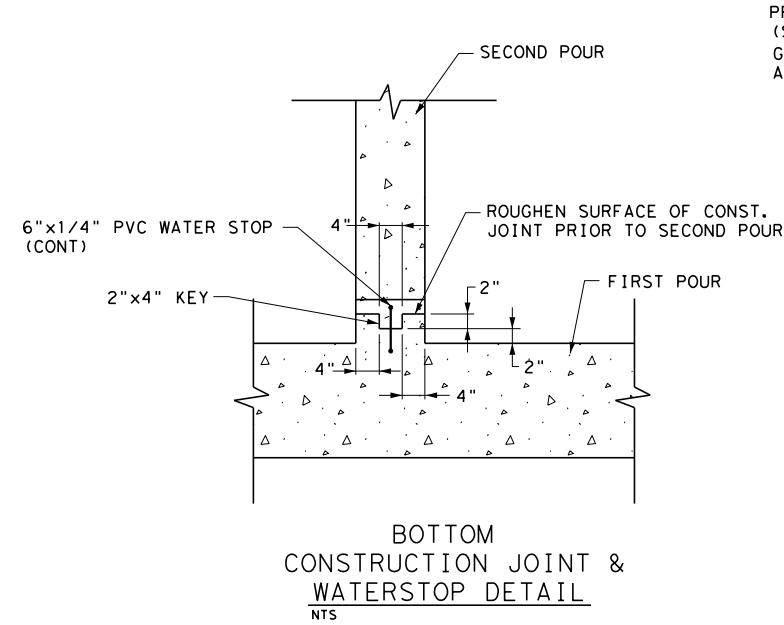
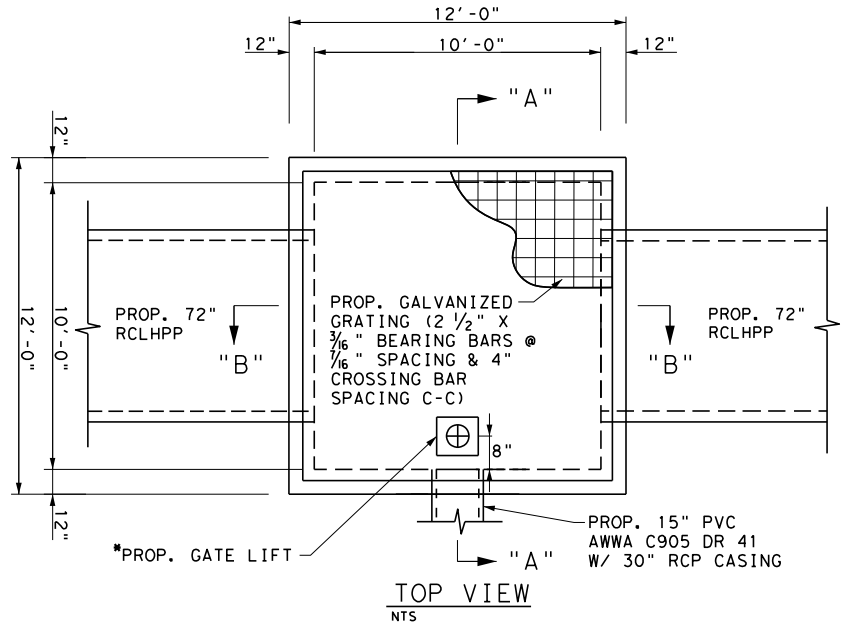

SH 365
 US 281 JUNCTION BOX
 CIP DETAILS

SHEET 1 OF 1

DN:	CONT	SECT	JOB	HIGHWAY
CK DN:	0921	02	368	365 TOLL
DW:	DIST	COUNTY	SHEET NO.	
CK DW:	PHR	HIDALGO	1207A	
TR:				
CK TR:				

JUNCTION BOX CIP DETAILS

NTS

EFFECTIVE PLAN SHEET - RELEASED FOR CONSTRUCTION; DATE 02/20/2026
 THIS SHEET HAS BEEN MODIFIED DURING CONSTRUCTION AS A RESULT OF A REQUEST FOR INFORMATION (RFI), FIELD CHANGE, OR CHANGE ORDER. THIS SHEET MODIFICATION IS INDEPENDENT OF DESIGN CHANGES FROM THE VECP PROCESS. THIS MODIFIED SHEET IS RELEASED FOR CONSTRUCTION.

DATE: 2/19/2026 6:45:19 PM
 FILE: c:\projectwise\dannenbaum-hcrma\workdir\copy of michael.meroney\dms78552\07_SH_365_0031_IRRX_P&P-R3-1195.dgn

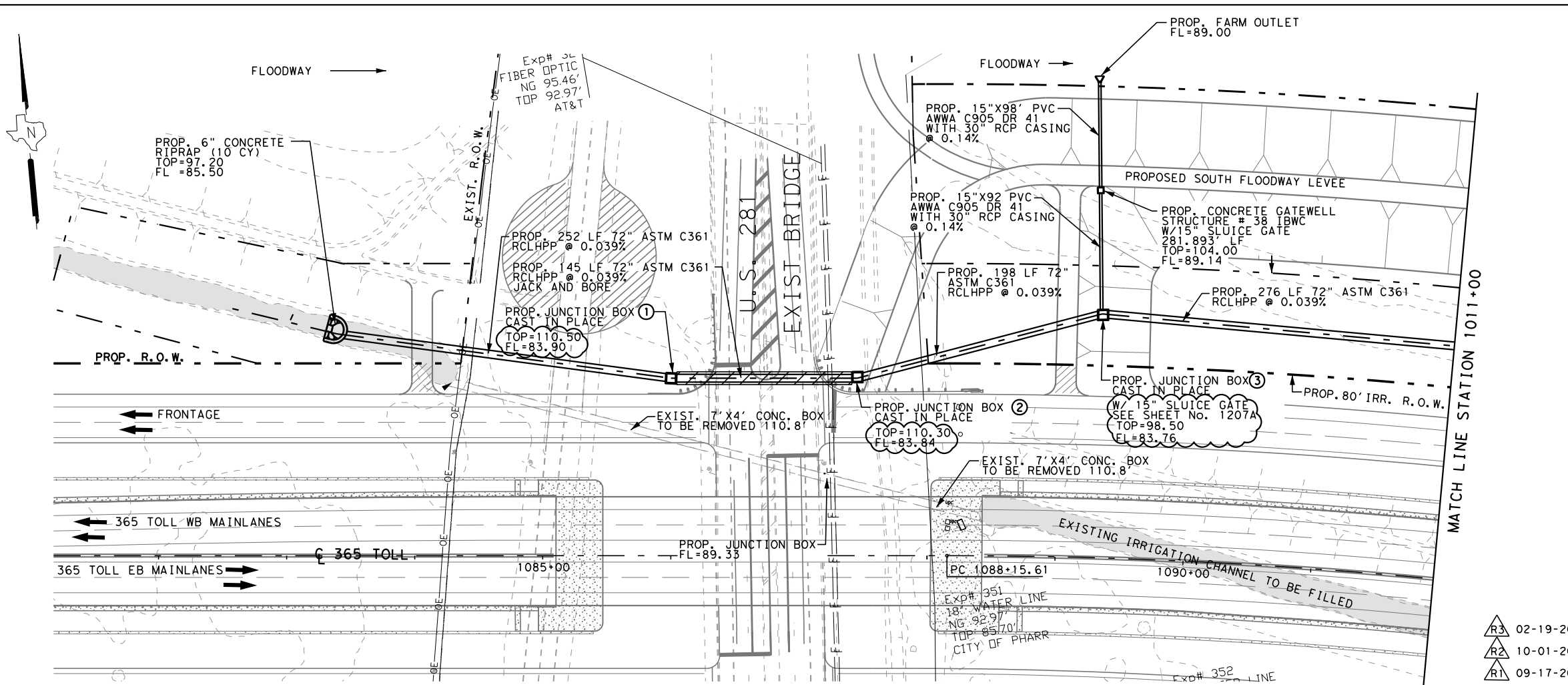

SHEET SUMMARY

ITEM	DESCRIPTION	UNIT	QUANTITY
400	STRUCTURE EXCAV (SPECIAL) (12" GRAVEL)	CY	228
432	CONCRETE RIP RAP (6IN)	CY	10
465	JUNCTION BOX CAST IN PLACE	EA	3
466	CONCRETE HEADWALL (CH-FW-O) 15 IN	EA	1
HCRMA 08	CONCRETE GATE WELL STRUCTURE	EA	1
4021	RC LOW HEAD PRSSR PIPE 72 in	LF	871
1008	PRSSR IRR (PVC) PIPE 15"	LF	190
464	30" RCP CL III	LF	190
1007	IRR GATE (15") (SLUICE)	EA	2
476	JACK BORE OR TUN PIPE (72") (RC) (CL V)	LF	100
1007	IRR VALVE (12") (FARM OUTLET)	EA	1

- LEGEND:**
- ⊗ NON-PAY, SUBSIDIARY TO PERTINENT BID ITEMS.
 - ★ TO BE REMOVED UNDER ITEM 496. INCLUDES PAYMENT FOR REMOVAL OF ALL APPURTENANCES.
 - ⊙ NON-PAY ITEM. FOR CONTRACTORS' INFORMATION ONLY.
 - ⊕ THE CONTRACTOR SHALL CONFIRM THAT THE TOP ELEVATION ON THE PROPOSED STANDPIPE IS AT THE SAME ELEVATION AS THE EXISTING STANDPIPE

- NOTES:**
- THE CONTRACTOR WILL COORDINATE WITH H.C.I.D. NO. 2 48 HOURS PRIOR TO COMMENCING ANY WORK AND PROVIDE SEQUENCE OF CONSTRUCTION STRUCTURES. SONNY HINOJOSA - (956)787-1422. SEE SHEET NO. 1224C FOR CONC. COLLAR DETAILS.
 - THE CONTRACTOR SHALL CONFIRM THAT CONFLICTS WITH EXISTING UTILITIES HAVE BEEN RESOLVED IN ADVANCE OF CONSTRUCTION. DAMAGES CAUSED BY OR TO EXISTING UTILITIES ARE THE RESPONSIBILITY OF THE CONTRACTOR.
 - ALL PVC ELBOWS, AND CONNECTIONS SHALL BE SUBSIDIARY TO PERTINENT BID ITEMS.
 - PROPOSED INSTALLATION AND REMOVAL OF BERMS AND PUMPING WATER WILL BE SUBSIDIARY TO ITEM 464.
 - REFER TO SHEET 1207A FOR CIP DETAILS

- △ R3 02-19-2026
- △ R2 10-01-2025
- △ R1 09-17-2024

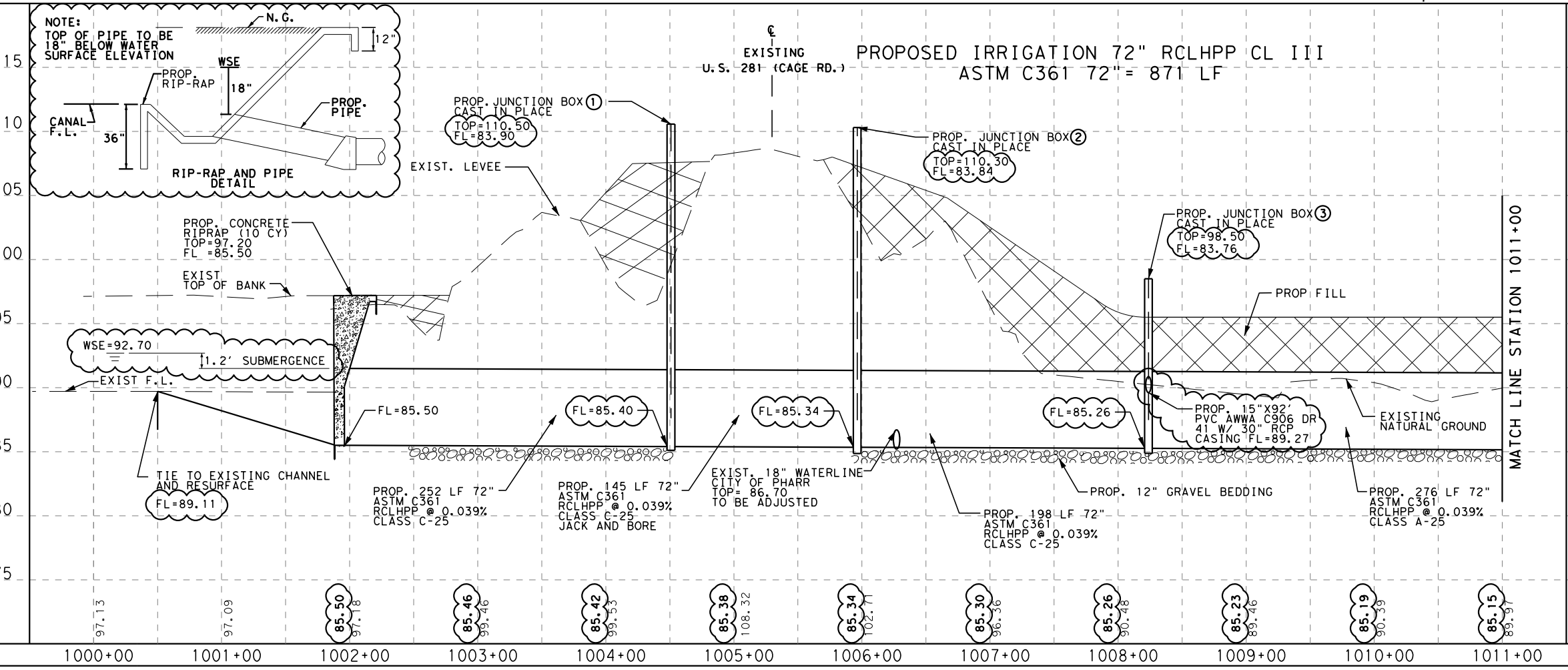

HDR ENGINEERING INC. F-754

NON-CLOUDED AREAS WILL BE THE RESPONSIBILITY OF THE ENGINEER OF RECORD, FOR THE RESPECTIVE CHANGES SHOWN IN PREVIOUS REVISIONS OF THIS SHEET.

PROPOSED IRRIGATION STRUCTURE
 AT U.S. 281 (CAGE BLVD)
 STA 1001+11 TO STA 1011+00

SCALE:
 HOR: 1" = 100'
 VER: 1" = 10'

SHEET 1 OF 3

CONTRACT	SECTION	JOB	HIGHWAY
0921	02	368	365 TOLL
DISTRICT	COUNTY	SHEET NO.	
PHR	HIDALGO	1195	

EFFECTIVE PLAN SHEET - RELEASED FOR CONSTRUCTION; DATE 02/20/2026
 THIS SHEET HAS BEEN MODIFIED DURING CONSTRUCTION AS A RESULT OF A REQUEST FOR INFORMATION (RFI), FIELD CHANGE, OR CHANGE ORDER. THIS SHEET MODIFICATION IS INDEPENDENT OF DESIGN CHANGES FROM THE VEP PROCESS. THIS MODIFIED SHEET IS RELEASED FOR CONSTRUCTION.

DATE: 12/23/2025 1:23:46 PM
 FILE: c:\projectwise\dannenbaum-hcrma\workdir\copy_of_michael.meroney\dms49948\08_SH_365_0031_IRRX_P&P-R2_1196.dgn

SHEET SUMMARY

ITEM	DESCRIPTION	UNIT	QUANTITY
465	JUNCTION BOX CAST IN PLACE	EA	2
4021	RC LOW HEAD PRSSR PIPE 72 in	LF	1100
400	STRUCT. EXCAVATION (SPECIAL) (12" GRAVEL)	CY	285

- LEGEND:**
- ⊗ NON-PAY, SUBSIDIARY TO PERTINENT BID ITEMS.
 - ★ TO BE REMOVED UNDER ITEM 496. INCLUDES PAYMENT FOR REMOVAL OF ALL APPURTENANCES.
 - ⊙ NON-PAY ITEM. FOR CONTRACTORS' INFORMATION ONLY.
 - ⊕ THE CONTRACTOR SHALL CONFIRM THAT THE TOP ELEVATION ON THE PROPOSED STANDPIPE IS AT THE SAME ELEVATION AS THE EXISTING STANDPIPE

- NOTES:**
- THE CONTRACTOR WILL COORDINATE WITH H.C.I.D. NO. 2 48 HOURS PRIOR TO COMMENCING ANY WORK AND PROVIDE SEQUENCE OF CONSTRUCTION STRUCTURES. SONNY HINOJOSA - (956)787-1422. SEE SHEET NO. 1224C FOR CONC. COLLAR DETAILS.
 - THE CONTRACTOR SHALL CONFIRM THAT CONFLICTS WITH EXISTING UTILITIES HAVE BEEN RESOLVED IN ADVANCE OF CONSTRUCTION. DAMAGES CAUSED BY OR TO EXISTING UTILITIES ARE THE RESPONSIBILITY OF THE CONTRACTOR.
 - ALL PVC ELBOWS, AND CONNECTIONS SHALL BE SUBSIDIARY TO PERTINENT BID ITEMS.
 - PROPOSED INSTALLATION AND REMOVAL OF BERMS AND PUMPING WATER WILL BE SUBSIDIARY TO ITEM 464.
 - REFER TO SHEET 1207A FOR CIP DETAILS

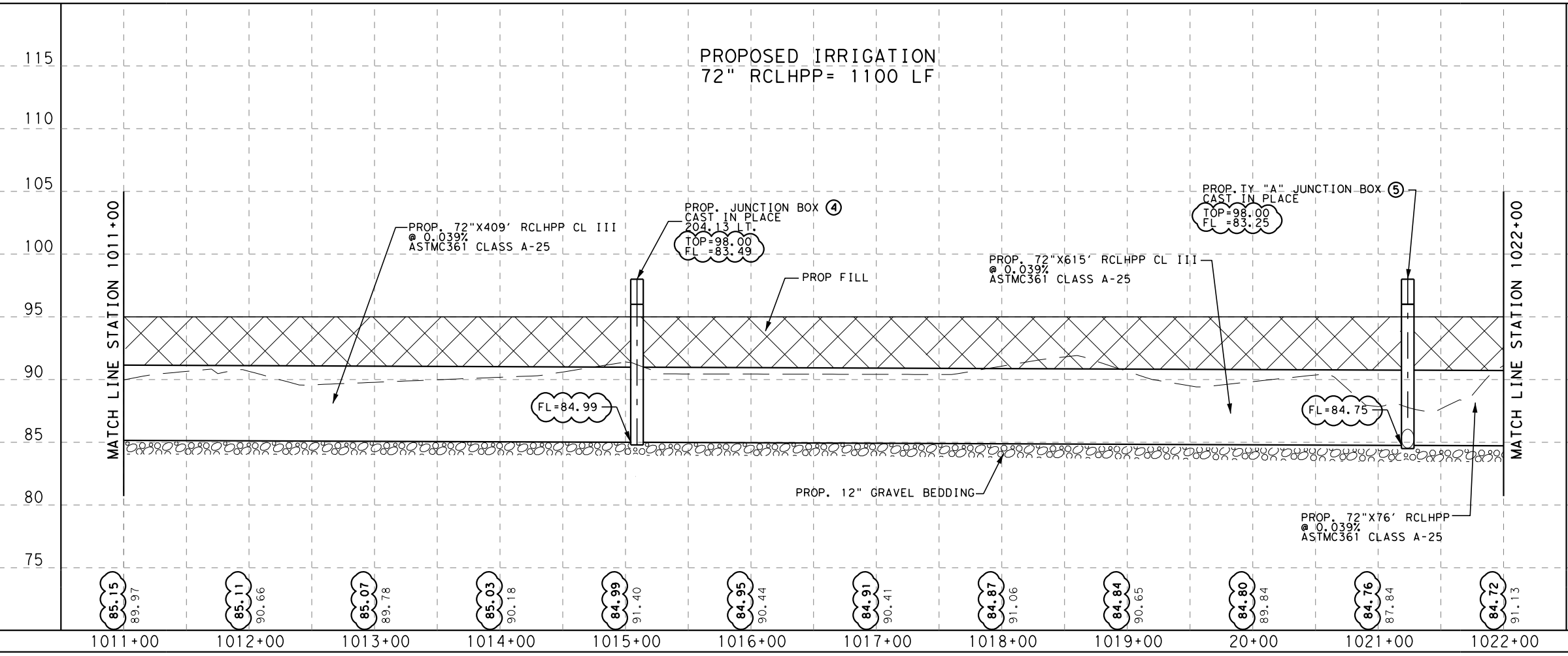
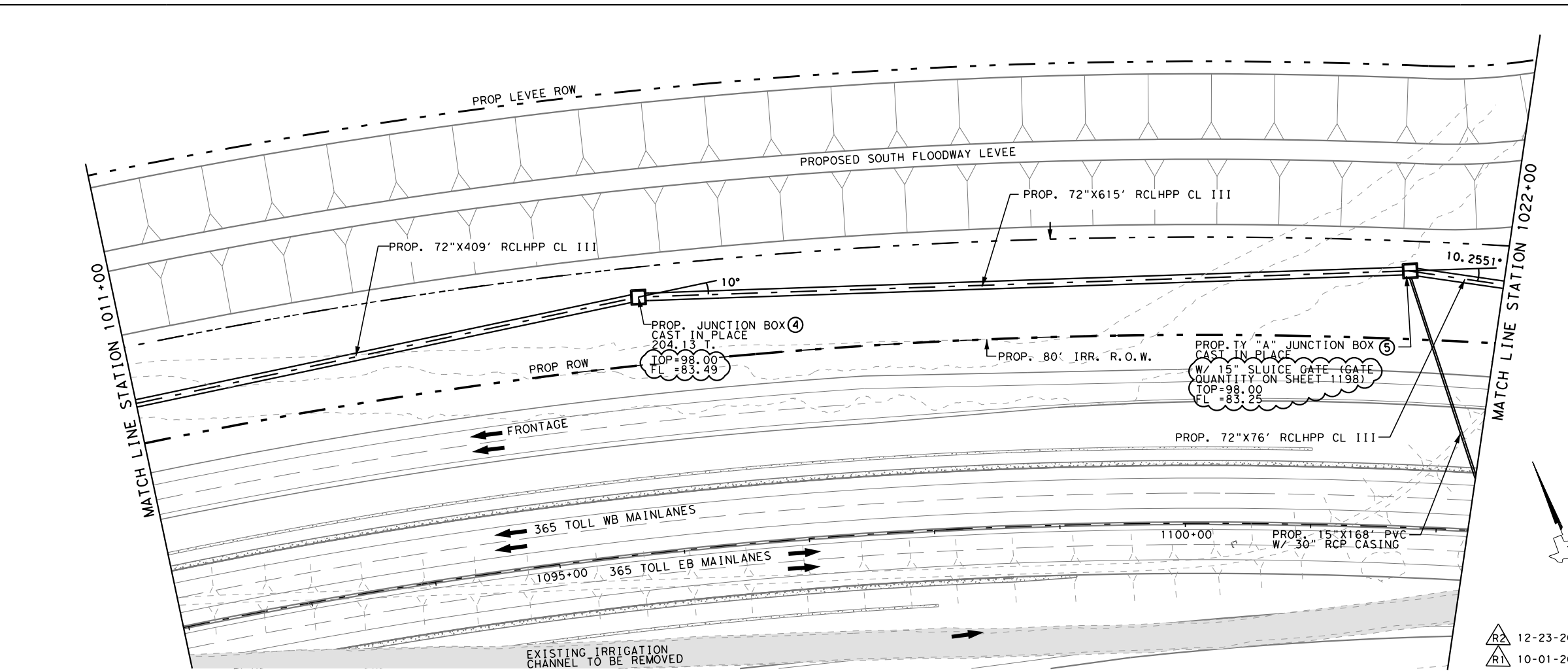

HDR ENGINEERING INC.
 F-754

MARC H. SORIANO
 128318
 LICENSED PROFESSIONAL ENGINEER
 12-23-2025 R2

NON-CLOUDED AREAS WILL BE THE RESPONSIBILITY OF THE ENGINEER OF RECORD, FOR THE RESPECTIVE CHANGES SHOWN IN PREVIOUS REVISIONS OF THIS SHEET.



PROPOSED IRRIGATION STRUCTURE AT U.S. 281 STA 1011+00 TO STA 1022+00

SCALE:
 HOR: 1" = 100'
 VER: 1" = 10'

SHEET 2 OF 3

CONTRACT NO.	0921	SECTION	02	JOB NO.	368	HIGHWAY	365 TOLL
DISTRICT	PHR	COUNTY	HIDALGO	SHEET NO.	1196		

EFFECTIVE PLAN SHEET - RELEASED FOR CONSTRUCTION; DATE 02/20/2026
 THIS SHEET HAS BEEN MODIFIED DURING CONSTRUCTION AS A RESULT OF A REQUEST FOR INFORMATION (RFI), FIELD CHANGE, OR CHANGE ORDER. THIS SHEET MODIFICATION IS INDEPENDENT OF DESIGN CHANGES FROM THE VECP PROCESS. THIS MODIFIED SHEET IS RELEASED FOR CONSTRUCTION.

DATE: 2/19/2026 6:43:37 PM
 FILE: c:\projectwise\dannenbaum-hcrma\workdir\copy of michael.meroney\dms49948\09_SH_365_0031_IRRX_P&P-R1_1197.dgn

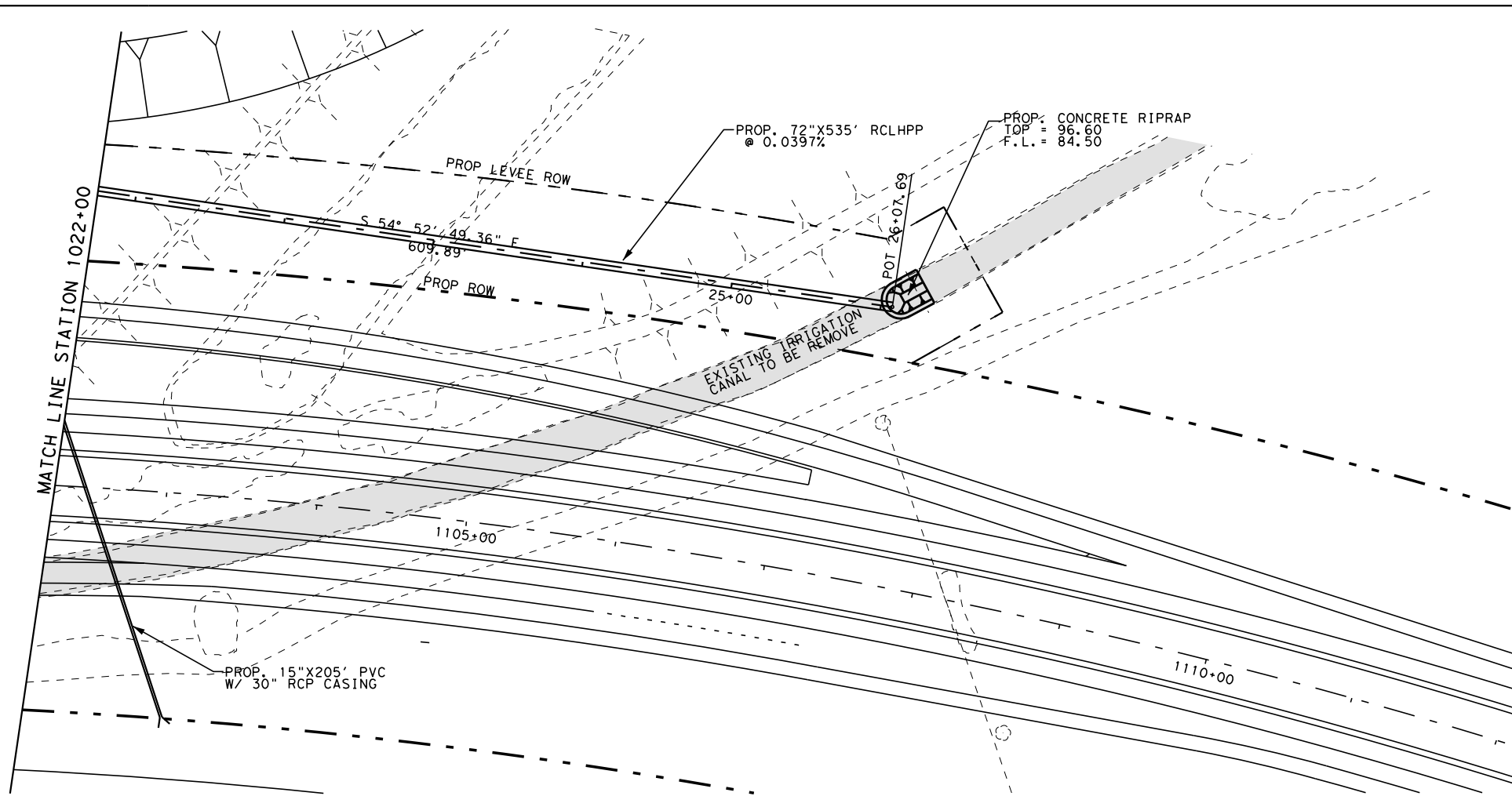

SHEET SUMMARY			
ITEM	DESCRIPTION	UNIT	QUANTITY
464	CONCRETE RIPRAP (6")	CY	20
4021	RC LOW HEAD PRRSR PIPE 72"	LF	535
400	STRUCT. EXCAVATION (SPECIAL) (12 GRAVEL)	CY	139
466	CONCRETE HEADWALL (12")	EA	1

- LEGEND:**
- ⊗ NON-PAY, SUBSIDIARY TO PERTINENT BID ITEMS.
 - ★ TO BE REMOVED UNDER ITEM 496. INCLUDES PAYMENT FOR REMOVAL OF ALL APPURTENANCES.
 - ⊙ NON-PAY ITEM. FOR CONTRACTORS' INFORMATION ONLY.
 - ⊕ THE CONTRACTOR SHALL CONFIRM THAT THE TOP ELEVATION ON THE PROPOSED STANDPIPE IS AT THE SAME ELEVATION AS THE EXISTING STANDPIPE

- NOTES:**
- THE CONTRACTOR WILL COORDINATE WITH H.C.I.D. NO.2 48 HOURS PRIOR TO COMMENCING ANY WORK AND PROVIDE SEQUENCE OF CONSTRUCTION STRUCTURES. SONNY HINOJOSA - (956)787-1422. SEE SHEET No. 1224C FOR CONC. COLLAR DETAILS.
 - THE CONTRACTOR SHALL CONFIRM THAT CONFLICTS WITH EXISTING UTILITIES HAVE BEEN RESOLVED IN ADVANCE OF CONSTRUCTION. DAMAGES CAUSED BY OR TO EXISTING UTILITIES ARE THE RESPONSIBILITY OF THE CONTRACTOR.
 - ALL PVC ELBOWS, AND CONNECTIONS SHALL BE SUBSIDIARY TO PERTINENT BID ITEMS.
 - PROPOSED INSTALLATION AND REMOVAL OF BERMS AND PUMPING WATER WILL BE SUBSIDIARY TO ITEM 464.

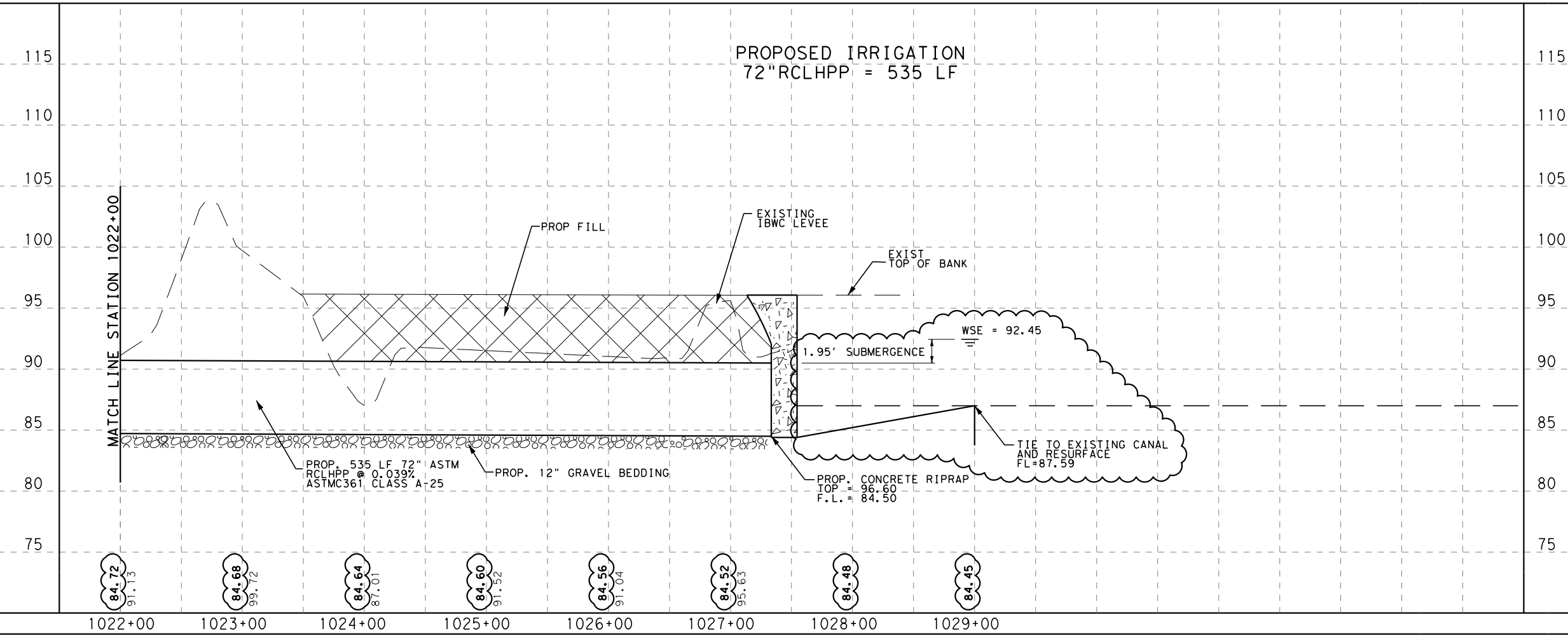

HDR ENGINEERING INC.
 F-754

NON-CLOUDED AREAS WILL BE THE RESPONSIBILITY OF THE ENGINEER OF RECORD, FOR THE RESPECTIVE CHANGES SHOWN IN PREVIOUS REVISIONS OF THIS SHEET.



S&BI
 S&B INFRASTRUCTURE, LTD.
 TEXAS BOARD OF PROFESSIONAL ENGINEERS #: F-1582

PROPOSED IRRIGATION STRUCTURE AT U.S. 281 STA 1022+00 TO STA 1027+33

SCALE:
 HOR: 1" = 100'
 VER: 1" = 10'

SHEET 3 OF 3

DN:	CON:	SECT:	JOB:	HIGHWAY:
CK DN:	0921	02	368	365 TOLL
TR:	DIST:	COUNTY:	SHEET NO.	
CK TR:	PHR	HIDALGO	1197	

EFFECTIVE PLAN SHEET - RELEASED FOR CONSTRUCTION: DATE 02/20/2026
 THIS SHEET HAS BEEN MODIFIED DURING CONSTRUCTION AS A RESULT OF A REQUEST FOR INFORMATION (RFI), FIELD CHANGE, OR CHANGE ORDER. THIS SHEET MODIFICATION IS INDEPENDENT OF DESIGN CHANGES FROM THE VECP PROCESS. THIS MODIFIED SHEET IS RELEASED FOR CONSTRUCTION.

DATE: 12/23/2025 4:25:32 PM
 FILE: c:\projectwise\dannenbaum-hcrma\workdir\copy of michael.meroney\dms49948\09A_SH_365_0031_IRRX_P&P-R1.dgn

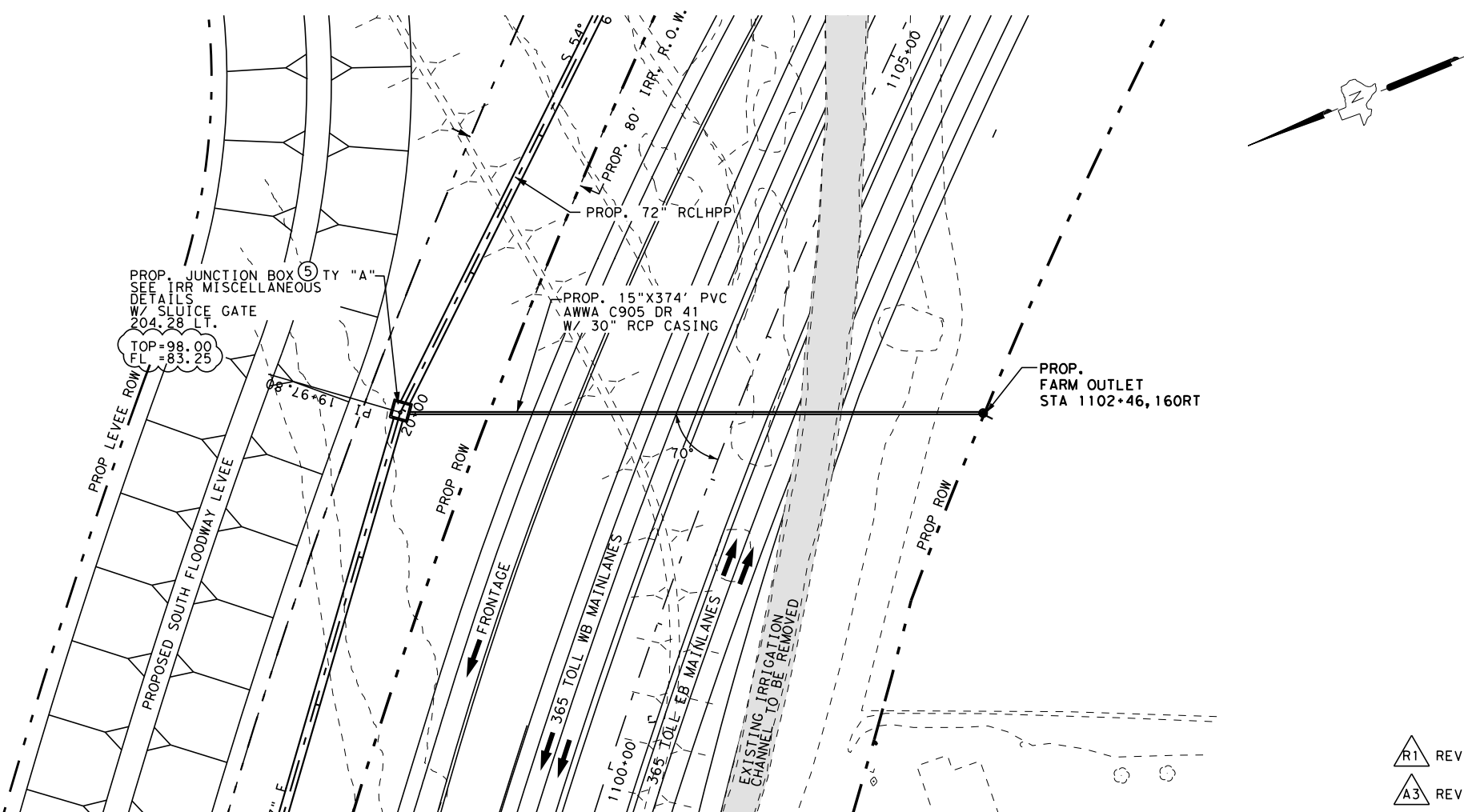

SHEET SUMMARY

ITEM	DESCRIPTION	UNIT	QUANTITY
1008	PRSSR IRR PVC PIPE 15"	LF	374
464	RLP CL III 30"	LF	374
1007	IRR VALVE (12") (FARM OULET)	EA	1
1007	IRR GATE (15") (SLUICE)	EA	1

- LEGEND:**
- ⊗ NON-PAY, SUBSIDIARY TO PERTINENT BID ITEMS.
 - ★ TO BE REMOVED UNDER ITEM 496. INCLUDES PAYMENT FOR REMOVAL OF ALL APPURTENANCES.
 - ⊙ NON-PAY ITEM. FOR CONTRACTORS' INFORMATION ONLY.
 - ⊕ THE CONTRACTOR SHALL CONFIRM THAT THE TOP ELEVATION ON THE PROPOSED STANDPIPE IS AT THE SAME ELEVATION AS THE EXISTING STANDPIPE

- NOTES:**
- THE CONTRACTOR WILL COORDINATE WITH H.C.I.D. NO.2 48 HOURS PRIOR TO COMMENCING ANY WORK AND PROVIDE SEQUENCE OF CONSTRUCTION STRUCTURES. SONNY HINOJOSA - (956)787-1422. SEE SHEET No. 1224C FOR CONC. COLLAR DETAILS.
 - THE CONTRACTOR SHALL CONFIRM THAT CONFLICTS WITH EXISTING UTILITIES HAVE BEEN RESOLVED IN ADVANCE OF CONSTRUCTION. DAMAGES CAUSED BY OR TO EXISTING UTILITIES ARE THE RESPONSIBILITY OF THE CONTRACTOR.
 - ALL PVC ELBOWS, AND CONNECTIONS SHALL BE SUBSIDIARY TO PERTINENT BID ITEMS.
 - PROPOSED INSTALLATION AND REMOVAL OF BERMS AND PUMPING WATER WILL BE SUBSIDIARY TO ITEM 464.

△R1 REVISED 12/23/2025
 △A3 REVISED 10/30/2017

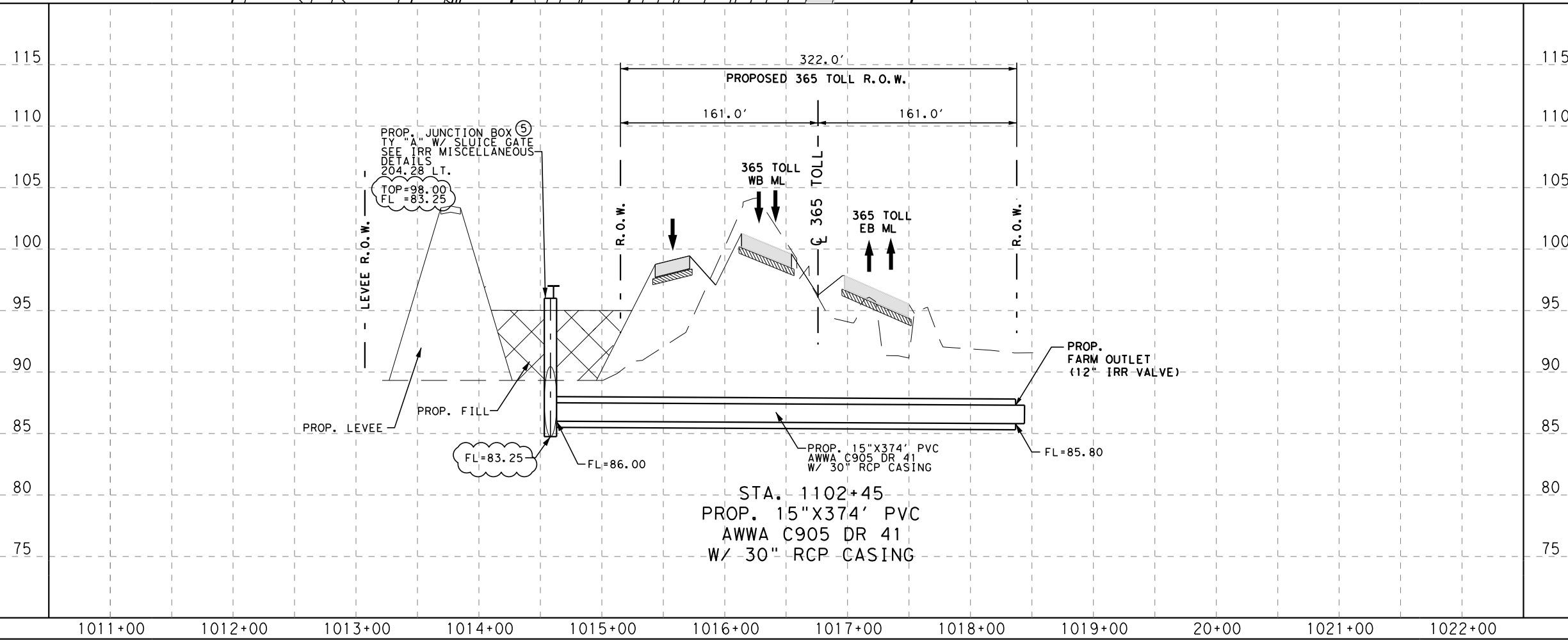

HDR ENGINEERING INC.
 F-754

NON-CLOUDED AREAS WILL BE THE RESPONSIBILITY OF THE ENGINEER OF RECORD, FOR THE RESPECTIVE CHANGES SHOWN IN PREVIOUS REVISIONS OF THIS SHEET.

PROPOSED IRRIGATION STRUCTURE AT STA 1102+45

SCALE:
 HOR: 1" = 100'
 VER: 1" = 10'

SHEET 1 OF 9

DN:	CONT	SECT	JOB	HIGHWAY
CK DN:	0921	02	368	365 TOLL
TR:	DIST	COUNTY	SHEET NO.	
CK TR:	PHR	HIDALGO	1198	

EFFECTIVE PLAN SHEET - RELEASED FOR CONSTRUCTION; DATE 02/20/2026
 THIS SHEET HAS BEEN MODIFIED DURING CONSTRUCTION AS A RESULT OF A REQUEST FOR INFORMATION (RFI), FIELD CHANGE, OR CHANGE ORDER. THIS SHEET MODIFICATION IS INDEPENDENT OF DESIGN CHANGES FROM THE VECP PROCESS. THIS MODIFIED SHEET IS RELEASED FOR CONSTRUCTION.

DATE: 2/20/2026 10:51:51 AM
 FILE: c:\projectwise\dannenbaum-hcrma\workdir\copy_of_michael.meroney\dms77126\hcrwid3\irrigdet_3.dgn

GENERAL NOTES

1. CHAMFER ALL EXPOSED CONC. CORNERS 1".
2. ALL CONCRETE SHALL HAVE A COMPRESSIVE STRENGTH OF 4000 P.S.I. AT 28 DAYS
3. ALL REINFORCING STEEL SHALL BE GRADE 60
4. LAP OR ANCHOR ALL STEEL A MINIMUM OF 30 DIA.'S. ALL HORZ. STEEL SHALL BE CONTINUOUS AROUND CORNERS.
5. REINFORCING BARS MAY BE ADJUSTED BUT SHALL PROVIDE A MINIMUM OF 2 INCHES CLEAR COVER
6. *PROP. SLUCIE GATE SHALL BE A FRESNO LIFT AND GATE (SQUARE) ® OR APPROVED EQUAL DESIGNED FOR 20' SEATED AND UNSEATED HEADS
 GATE SHALL HAVE 316 STAINLESS STEEL SIDE ANGLES (FRAME), 316 STAINLESS STEEL STEM, GEARED LIFT, PACKING GLAND, & PEDISTAL MADE OF CAST IRON.
7. PROP. GALVANIZED FRAME AND GRATE SHALL BE SUBSIDIARY TO CIP JUNCTION BOX (12")

TABLE A:

JUNCTION BOX NO.	TOP ELEV.	FLOWLINE ELEV.
①	110.50	83.90
②	110.30	83.84
③*	98.50	83.76
④	98.00	83.49
⑤*	98.00	83.25

* ONLY JUNCTION BOXES ③ AND ⑤ INCLUDE 15" SLUICE GATE

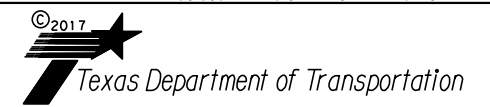
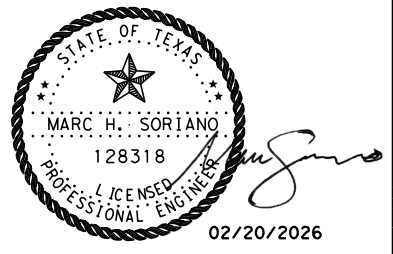
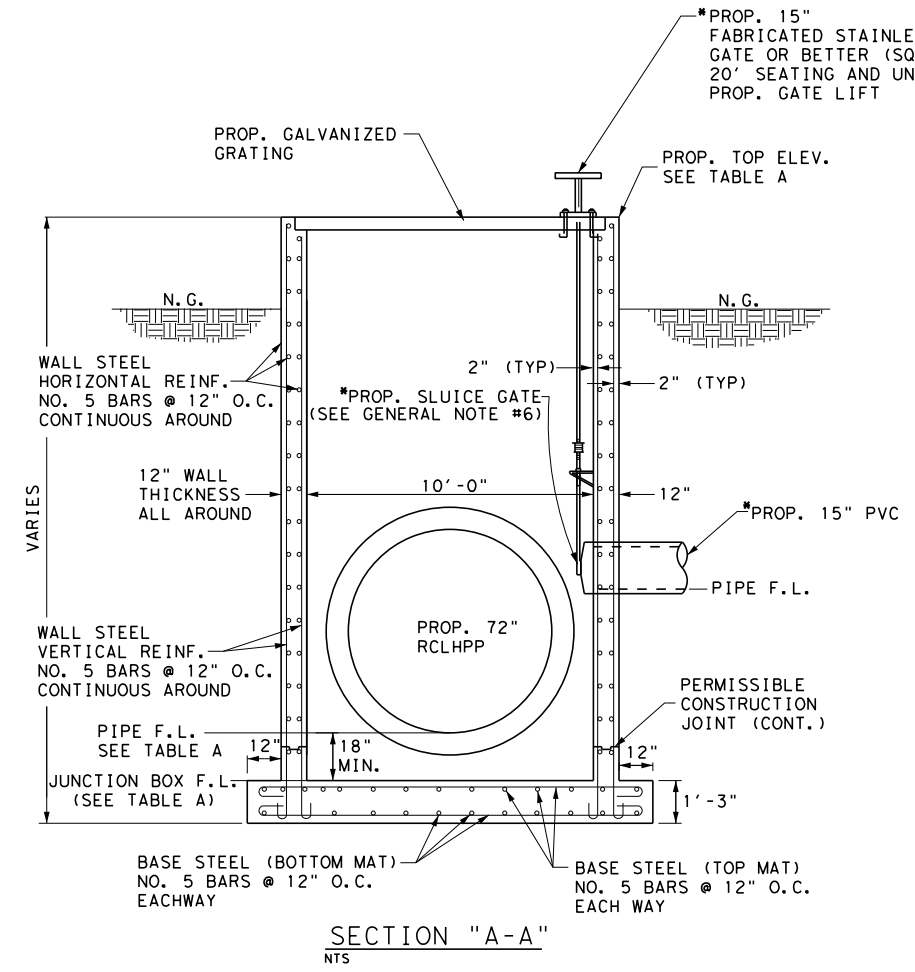
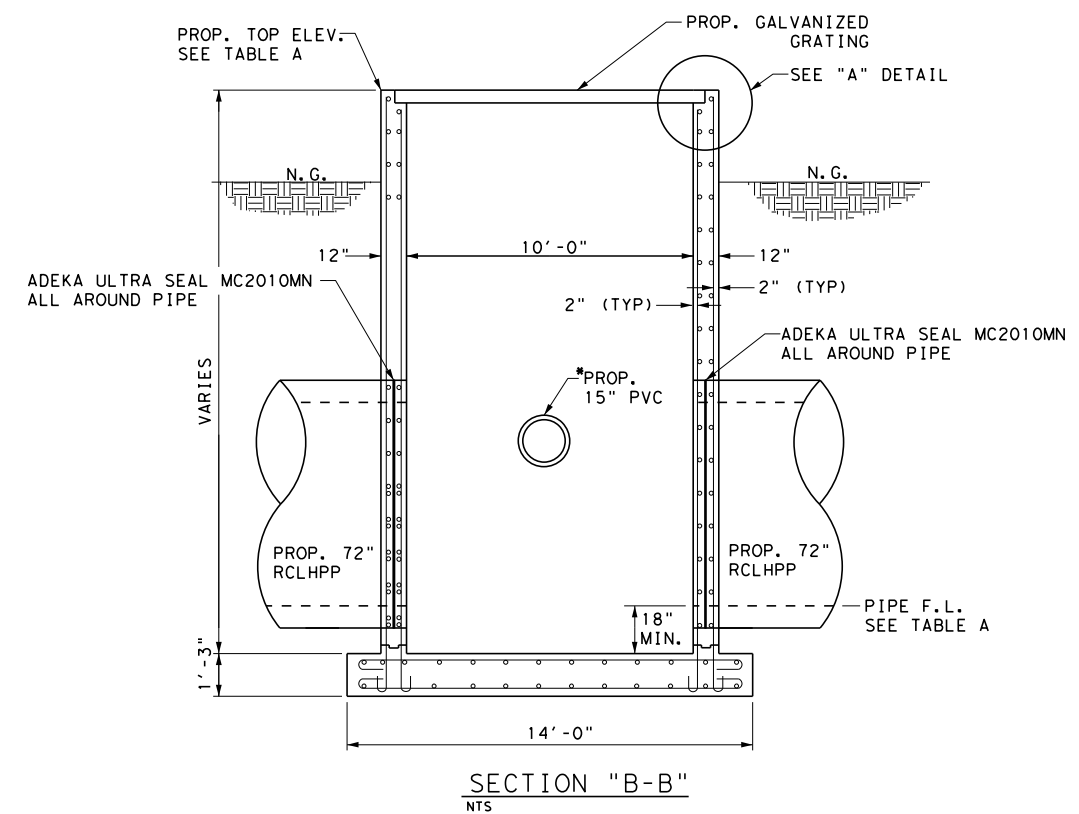
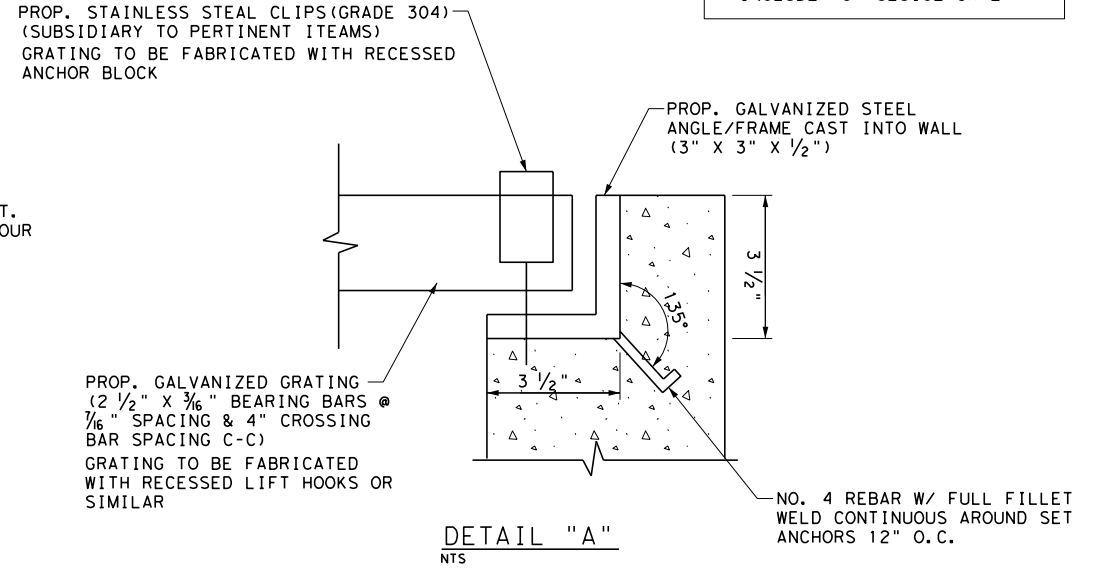
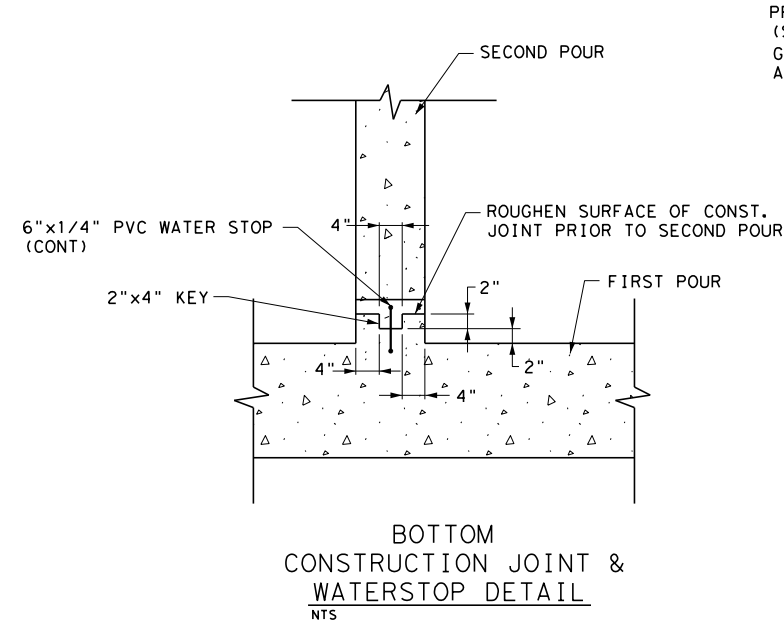
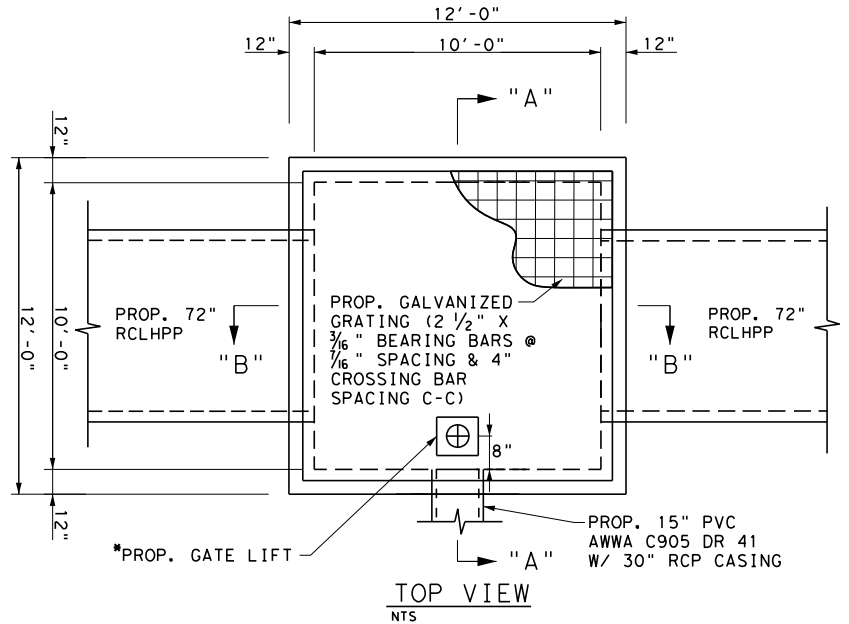

HDR HDR Engineering, Inc.
 FIRM REGISTRATION No. 754

SH 365
 US 281 JUNCTION BOX
 CIP DETAILS

SHEET 1 OF 1

DN:	CONT	SECT	JOB	HIGHWAY
CK DN:	0921	02	368	365 TOLL
DW:	DIST	COUNTY	SHEET NO.	
CK DW:	PHR	HIDALGO	1207A	
TR:				
CK TR:				

JUNCTION BOX CIP DETAILS

NTS

EFFECTIVE PLAN SHEET - RELEASED FOR CONSTRUCTION; DATE 02/20/2026
 THIS SHEET HAS BEEN MODIFIED DURING CONSTRUCTION AS A RESULT OF A REQUEST FOR INFORMATION (RFI), FIELD CHANGE, OR CHANGE ORDER. THIS SHEET MODIFICATION IS INDEPENDENT OF DESIGN CHANGES FROM THE VEP PROCESS. THIS MODIFIED SHEET IS RELEASED FOR CONSTRUCTION.

DATE: 2/20/2026 2:52:03 PM
 FILE: c:\projectwise\dannenbaum-hcrma\workdir\copy of mi.chaoe\mrc\oney\dms49948\SH_365_0031_1_IRRX_P&P_bypass_05-R2-1215.dgn

SEQUENCE OF CONSTRUCTION

PHASE I
 CONSTRUCT 72" RCLHPP STARTING FROM APPROXIMATELY STA 1084+50, 160' LT TO STA 1106+75, 180' LT (C 365 TOLL) JUST OUTSIDE THE EXISTING CANAL EMBANKMENT LIMITS AT BOTH ENDS SO AS TO NOT DISTURB OPERATION OF EXISTING CANAL.

PHASE II
 INSTALL TEMPORARY BERMS AS SHOWN IN PLANS AND MAKE CONNECTIONS FROM NEWLY INSTALLED 72" RCLHPP TO EXISTING IRRIGATION CANAL AT BOTH SIDES. REMOVE TEMPORARY BERMS UPON COMPLETION OF 72" RCLHPP CONNECTION AND CONSTRUCTION OF RIP RAP BASKETS ON BOTH ENDS OF THE IRRIGATION STRUCTURES.

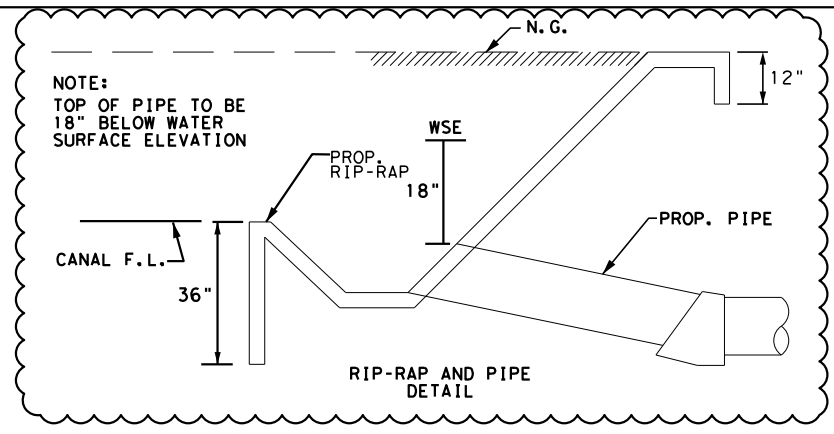

SHEET SUMMARY

ITEM	DESCRIPTION	UNIT	QUANTITY
110	EXCAVATION CHANNEL	CY	830
132	EMBANKMENT CHANNEL	CY	830

- NOTES:**
1. THE CONTRACTOR WILL COORDINATE WITH H.C.I.D. NO. 2 AND ENGINEER 48 HOURS PRIOR TO COMMENCING ANY WORK AND PROVIDE SEQUENCE OF CONSTRUCTION STRUCTURES. SONNY HINOJOSA - (956) 787-1422.
 2. THE CONTRACTOR SHALL CONFIRM THAT CONFLICTS WITH EXISTING UTILITIES HAVE BEEN RESOLVED IN ADVANCE OF CONSTRUCTION. DAMAGES CAUSED BY OR TO EXISTING UTILITIES ARE THE RESPONSIBILITY OF THE CONTRACTOR.
 3. ALL PVC ELBOWS, AND CONNECTIONS SHALL BE SUBSIDIARY TO PERTINENT BID ITEMS.
 4. PROPOSED INSTALLATION AND REMOVAL OF BERMS AND PUMPING WATER WILL BE SUBSIDIARY TO ITEM 464.
 5. ALL WORK MUST BE COMPLETED WITH 48 HOURS OF ANY SHUTDOWN.

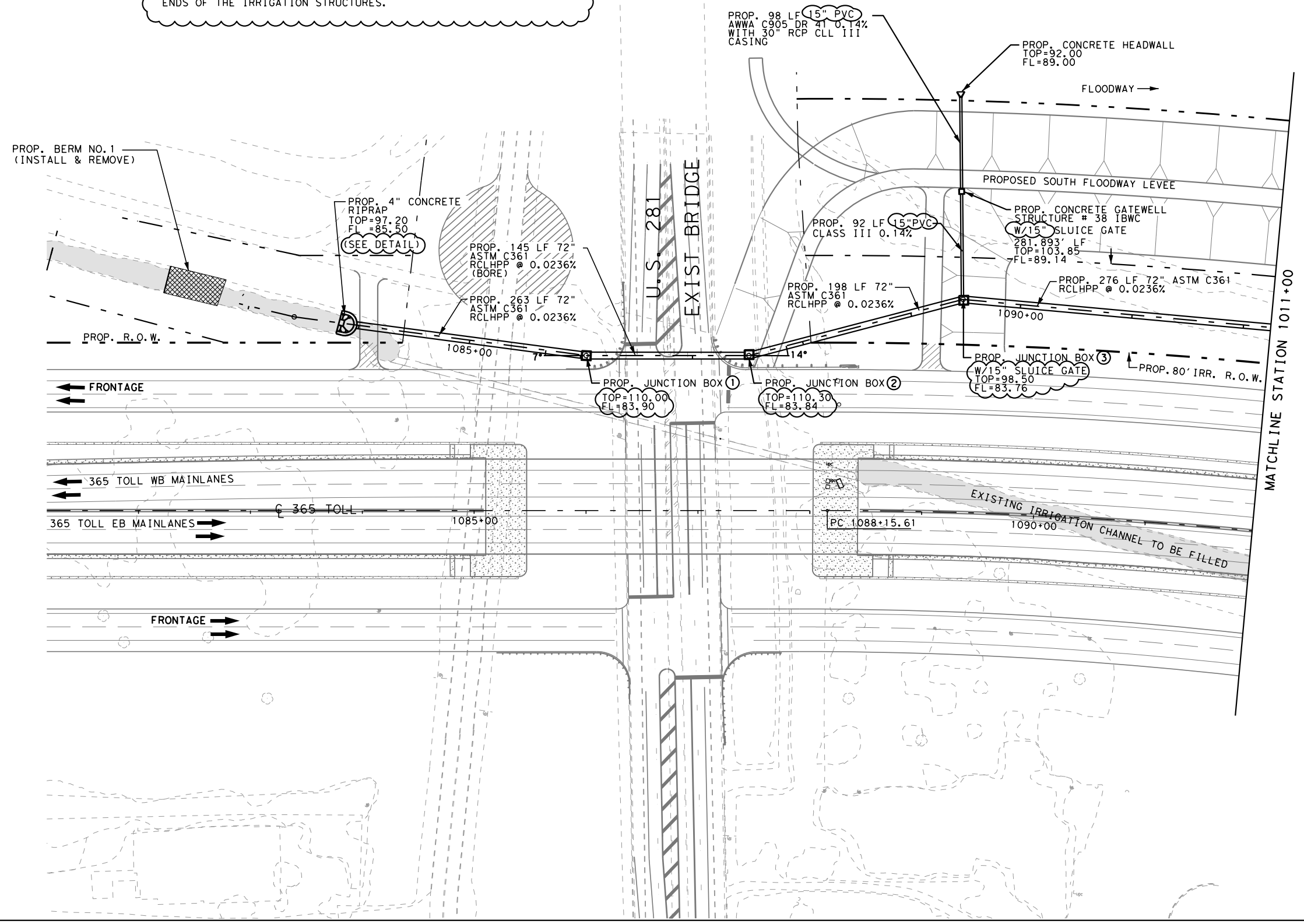

HDR ENGINEERING INC.
 F-754

MARC H. SORIANO
 128318
 LICENSED PROFESSIONAL ENGINEER
 02/20/2026 R2

NON-CLOUDED AREAS WILL BE THE RESPONSIBILITY OF THE ENGINEER OF RECORD, FOR THE RESPECTIVE CHANGES SHOWN IN PREVIOUS REVISIONS OF THIS SHEET.



S&BI
 S&B INFRASTRUCTURE, LTD.
 TEXAS BOARD OF PROFESSIONAL ENGINEERS #: F-1582

PROPOSED IRRIGATION BYPASS AT US 281 (CAGE BLVD) STA 1001+27 TO STA 1011+00

SCALE: 1" = 100' SHEET 1 OF 3

DN:	CONT	SECT	JOB	HIGHWAY
CK DN:	0921	02	368	365 TOLL
TR:	DIST	COUNTY	SHEET NO.	
CK TR:	PHR	HIDALGO	1215	

R2 02/20/2026
 R1 10/01/2025

EFFECTIVE PLAN SHEET - RELEASED FOR CONSTRUCTION; DATE 02/20/2026
 THIS SHEET HAS BEEN MODIFIED DURING CONSTRUCTION AS A RESULT OF A REQUEST FOR INFORMATION (RFI), FIELD CHANGE, OR CHANGE ORDER. THIS SHEET MODIFICATION IS INDEPENDENT OF DESIGN CHANGES FROM THE VECP PROCESS. THIS MODIFIED SHEET IS RELEASED FOR CONSTRUCTION.

DATE: 12/23/2025 4:06:13 PM
 FILE: c:\projectwise\dannenbaum-hcrma\workdir\copy_of_michael.meroney\dms49948\SH_365_0031_IRRX_P&P_bypass_05a-R2-1216.dgn



- NOTES:**
1. THE CONTRACTOR WILL COORDINATE WITH H.C.I.D. NO. 2 AND ENGINEER 48 HOURS PRIOR TO COMMENCING ANY WORK AND PROVIDE SEQUENCE OF CONSTRUCTION STRUCTURES. SONNY HINOJOSA - (956) 787-1422.
 2. THE CONTRACTOR SHALL CONFIRM THAT CONFLICTS WITH EXISTING UTILITIES HAVE BEEN RESOLVED IN ADVANCE OF CONSTRUCTION. DAMAGES CAUSED BY OR TO EXISTING UTILITIES ARE THE RESPONSIBILITY OF THE CONTRACTOR.
 3. ALL PVC ELBOWS, AND CONNECTIONS SHALL BE SUBSIDIARY TO PERTINENT BID ITEMS.
 4. PROPOSED INSTALLATION AND REMOVAL OF BERMS AND PUMPING WATER WILL BE SUBSIDIARY TO ITEM 464.
 5. ALL WORK MUST BE COMPLETED WITH 48 HOURS OF ANY SHUTDOWN.

HDR ENGINEERING INC.
 F-754

MARC H. SORIANO
 128318
 LICENSED PROFESSIONAL ENGINEER
 12-23-2025 R2

NON-CLOUDED AREAS WILL BE THE RESPONSIBILITY OF THE ENGINEER OF RECORD, FOR THE RESPECTIVE CHANGES SHOWN IN PREVIOUS REVISIONS OF THIS SHEET.



S&BI
 S&B INFRASTRUCTURE, LTD.
 TEXAS BOARD OF PROFESSIONAL ENGINEERS #: F-1582

PROPOSED IRRIGATION BYPASS AT US 281 (CAGE BLVD) STA 1011+00 TO STA 1022+00

SCALE: 1" = 100' SHEET 2 OF 3

DN:	CONT	SECT	JOB	HIGHWAY
CK DN:	0921	02	368	365 TOLL
TR:	DIST	COUNTY	SHEET NO.	
CK TR:	PHR	HIDALGO	1216	

R2 12-23-2025
 R1 10/01/2025

EFFECTIVE PLAN SHEET - RELEASED FOR CONSTRUCTION; DATE 02/20/2026
 THIS SHEET HAS BEEN MODIFIED DURING CONSTRUCTION AS A RESULT OF A REQUEST
 FOR INFORMATION (RFI), FIELD CHANGE, OR CHANGE ORDER. THIS SHEET
 MODIFICATION IS INDEPENDENT OF DESIGN CHANGES FROM THE VECP PROCESS. THIS
 MODIFIED SHEET IS RELEASED FOR CONSTRUCTION.

DATE: 12/23/2025 4:09:35 PM
 FILE: c:\projectwise\dannenbaum-hcrma\workdir\copy_of_michael.meroney\dms49948\SH_365_0031_IRRX_P&P_BYPASS_06-R2-1217.dgn

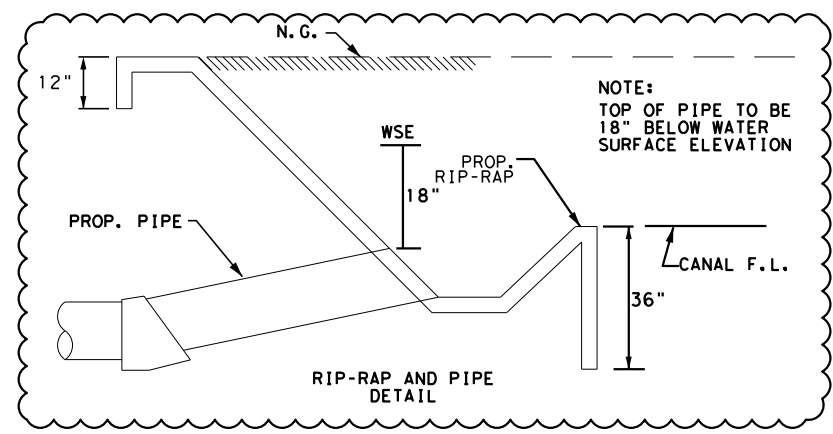
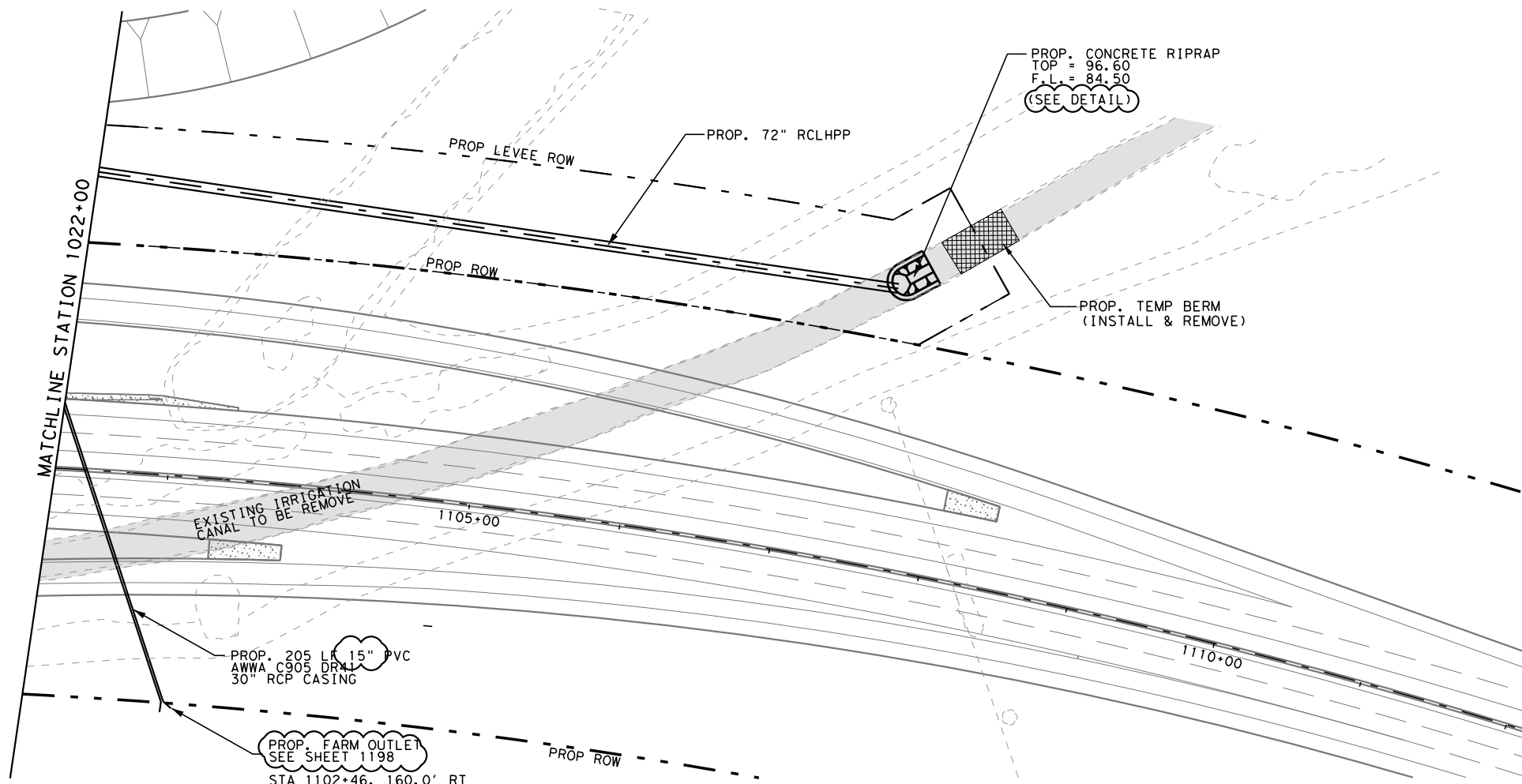

SHEET SUMMARY

ITEM	DESCRIPTION	UNIT	QUANTITY
110	EXCAVATION CHANNEL	CY	830
132	EMBANKMENT CHANNEL	CY	830

- NOTES:**
1. THE CONTRACTOR WILL COORDINATE WITH H.C.I.D. NO.2 AND ENGINEER 48 HOURS PRIOR TO COMMENCING ANY WORK AND PROVIDE SEQUENCE OF CONSTRUCTION STRUCTURES. SONNY HINOJOSA - (956)787-1422.
 2. THE CONTRACTOR SHALL CONFIRM THAT CONFLICTS WITH EXISTING UTILITIES HAVE BEEN RESOLVED IN ADVANCE OF CONSTRUCTION. DAMAGES CAUSED BY OR TO EXISTING UTILITIES ARE THE RESPONSIBILITY OF THE CONTRACTOR.
 3. ALL PVC ELBOWS, AND CONNECTIONS SHALL BE SUBSIDIARY TO PERTINENT BID ITEMS.
 4. PROPOSED INSTALLATION AND REMOVAL OF BERMS AND PUMPING WATER WILL BE SUBSIDIARY TO ITEM 464.
 5. ALL WORK MUST BE COMPLETED WITH 48 HOURS OF ANY SHUTDOWN.

HDR ENGINEERING INC.
F-754

MARC H. SORIANO
128318
LICENSED PROFESSIONAL ENGINEER
12-23-2025 R2

NON-CLOUDED AREAS WILL BE THE RESPONSIBILITY OF THE ENGINEER OF RECORD, FOR THE RESPECTIVE CHANGES SHOWN IN PREVIOUS REVISIONS OF THIS SHEET.



S&BI
S&B INFRASTRUCTURE, LTD.
TEXAS BOARD OF PROFESSIONAL ENGINEERS #: F-1582

PROPOSED IRRIGATION BYPASS AT US 281 (CAGE BLVD) STA 1022+00 TO STA 1027+33

SCALE: 1" = 100' SHEET 3 OF 3

DN:	CONT	SECT	JOB	HIGHWAY
CK DN:	0921	02	368	365 TOLL
DN:	DIST	COUNTY	SHEET NO.	
CK DN:	PHR	HIDALGO	1217	
TR:				
CK TR:				

R2 12-23-2025
 R1 10/01/2025



Memorandum

To: PilarRodriguez, PE, Executive Director

From: Ramon Navarro IV, P.E., Chief Construction Engineer

Date: Dec. 11, 2024

Re: **2024-52: CONSIDERATION AND APPROVAL OF CHANGE ORDERS NUMBER 14 TO THAT CERTAIN CONSTRUCTION CONTRACT WITH PULICE CONSTRUCTION, INC. FOR THE 365 TOLLWAY.**

GOAL

We are seeking Boards authorization to execute CO#14. This would direct Pulice to remove current pre-casted junction boxes /manholes and replace with monolithic cast-in-place structures.

BACKGROUND

HCRMA, HDR, Pulice Construction Inc. and HCID#2 have been negotiating various items since the implementation of the project. The HCRMA and HCID#2 have agreements in-place requiring concurrences to current plans, specifications, and implemented changes. HCID#2 is demanding immediate cost, scheduling impactive changes throughout project. After proposing various alternatives HCID#2 remains steadfast on implementing desired amendments to plans, specifications, and current agreements at no cost to them.

Change Order No. 14

The scope of this change is to remove and replace the approved precast junction boxes for cast-in-place irrigation structures and to dispose the existing precast material. PCI has provided proposal for \$492,363.86 and requested a time extension as it will have a significant impact on a critical section of the project.

Item	Description	Unit	Unit Price	Original Qty	CO Qty	Revised Qty	CO Amount
0465-6011	JCTBOX(COMPL)(PJB)(6FTX6FT}	EA	\$ 10,118.07	2	-2	0	\$ (20,236.14}
0465-6012	JCTBOX(COMPL)(PJB)(8FTX8FT)	EA	\$ 19,000.00	5	-5	0	\$ (95,000.00)
	JCTBOX(CIP}	EA	\$ 66,000.00	0	7	7	\$ 462,000.00
	JCTBOX(Material/Partial Installation)	EA	\$ 13,300.00	0	7	7	\$ 93,100.00
	JCTBOX(Removal/Disposal)	EA	\$ 7,500.00	0	7	7	\$ 52,500.00

\$ 492,363.86

HCRMA staff and HDR recommend Board authorize the HCRMA Executive Director to execute the specifics on Change Order#14 final approval. Staff is currently negotiating particulars and anticipate a lower cost, assurance of compliance with the standard specifications included within the contract with no additional time. All is dependent upon acceptance from FHWA/TxDOT and HCRMA Legal's review of final form. Change Order establishes no State nor Federal monetary participation. Attached exhibits provide current assessment and breakdown.

RECOMMENDATION:

HCRMA staff and HDR recommend approval of Resolution 2024-52 authorizing Change Order #14 to that certain construction contract with Pulice Construction Inc. for the 365 Tollway Project. The sum of Change Order proves a maximum cost increase of \$492,363.86 to be fully paid by HCRMA, no State/Federal participation on costs; establishing a new revised contract price of \$287,053,007.09 with no additional time.



Memorandum

To: Pilar Rodriguez, PE, Executive Director

From: Ramon Navarro IV, P.E., Chief Construction Engineer

Date: January 17, 2025

Re: **2025-07: CONSIDERATION AND APPROVAL OF REVISED CHANGE ORDERS NUMBER 14 TO THAT CERTAIN CONSTRUCTION CONTRACT WITH PULICE CONSTRUCTION, INC. FOR THE 365 TOLLWAY.**

GOAL

We are informing Board of final negotiated price of Revised CO#14.

BACKGROUND

HCRMA, HDR, Pulice Construction Inc. and HCID#2 have been negotiating various items since the implementation of the project. The HCRMA and HCID#2 have agreements in-place requiring concurrences to current plans, specifications, and implemented changes. HCID#2 is demanding immediate cost, scheduling impactive changes throughout project. After proposing various alternatives HCID#2 remains steadfast on implementing desired amendments to plans, specifications, and current agreements at no cost to them.

Board approved Resolution 2024-52 authorizing Change Order #14 at maximum cost not to exceed \$492,363.86

Change Order No. 14

The scope of this change order remains in full effect. PCI has provided proposal for a savings of \$42,927.50 and requested a time extension as it will have a significant impact on a critical section of the project.

RECOMMENDATION

HCRMA \ HDR staff recommend Board's approval and acceptance of CO#14, Resolution 2025-07 authorizing Change Order #14 to that certain construction contract with Pulice Construction Inc. for the 365 Tollway Project. in the amount of \$449,436.36, assurance of compliance with the standard specifications included within the contract with no additional time. All is dependent upon acceptance from FHWA/TxDOT and HCRMA Legal's review of final form. Change Order establishes no State nor Federal monetary participation. Attached exhibits provide current assessment and breakdown.